



This is a digital copy of a book that was preserved for generations on library shelves before it was carefully scanned by Google as part of a project to make the world's books discoverable online.

It has survived long enough for the copyright to expire and the book to enter the public domain. A public domain book is one that was never subject to copyright or whose legal copyright term has expired. Whether a book is in the public domain may vary country to country. Public domain books are our gateways to the past, representing a wealth of history, culture and knowledge that's often difficult to discover.

Marks, notations and other marginalia present in the original volume will appear in this file - a reminder of this book's long journey from the publisher to a library and finally to you.

Usage guidelines

Google is proud to partner with libraries to digitize public domain materials and make them widely accessible. Public domain books belong to the public and we are merely their custodians. Nevertheless, this work is expensive, so in order to keep providing this resource, we have taken steps to prevent abuse by commercial parties, including placing technical restrictions on automated querying.

We also ask that you:

- + *Make non-commercial use of the files* We designed Google Book Search for use by individuals, and we request that you use these files for personal, non-commercial purposes.
- + *Refrain from automated querying* Do not send automated queries of any sort to Google's system: If you are conducting research on machine translation, optical character recognition or other areas where access to a large amount of text is helpful, please contact us. We encourage the use of public domain materials for these purposes and may be able to help.
- + *Maintain attribution* The Google "watermark" you see on each file is essential for informing people about this project and helping them find additional materials through Google Book Search. Please do not remove it.
- + *Keep it legal* Whatever your use, remember that you are responsible for ensuring that what you are doing is legal. Do not assume that just because we believe a book is in the public domain for users in the United States, that the work is also in the public domain for users in other countries. Whether a book is still in copyright varies from country to country, and we can't offer guidance on whether any specific use of any specific book is allowed. Please do not assume that a book's appearance in Google Book Search means it can be used in any manner anywhere in the world. Copyright infringement liability can be quite severe.

About Google Book Search

Google's mission is to organize the world's information and to make it universally accessible and useful. Google Book Search helps readers discover the world's books while helping authors and publishers reach new audiences. You can search through the full text of this book on the web at <http://books.google.com/>



**General Library System
University of Wisconsin-Madison
728 State Street
Madison, WI 53706-1494
U.S.A.**



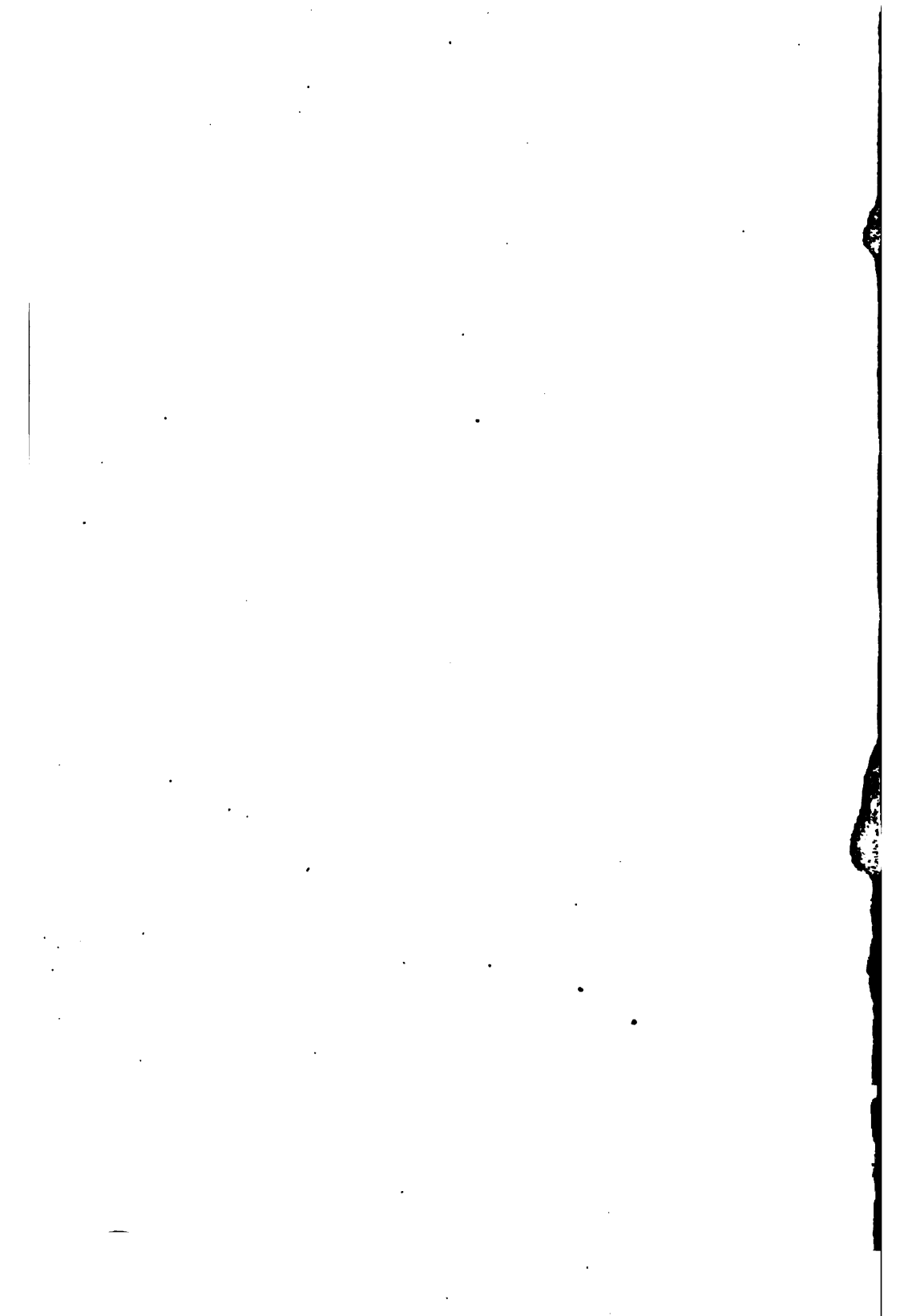



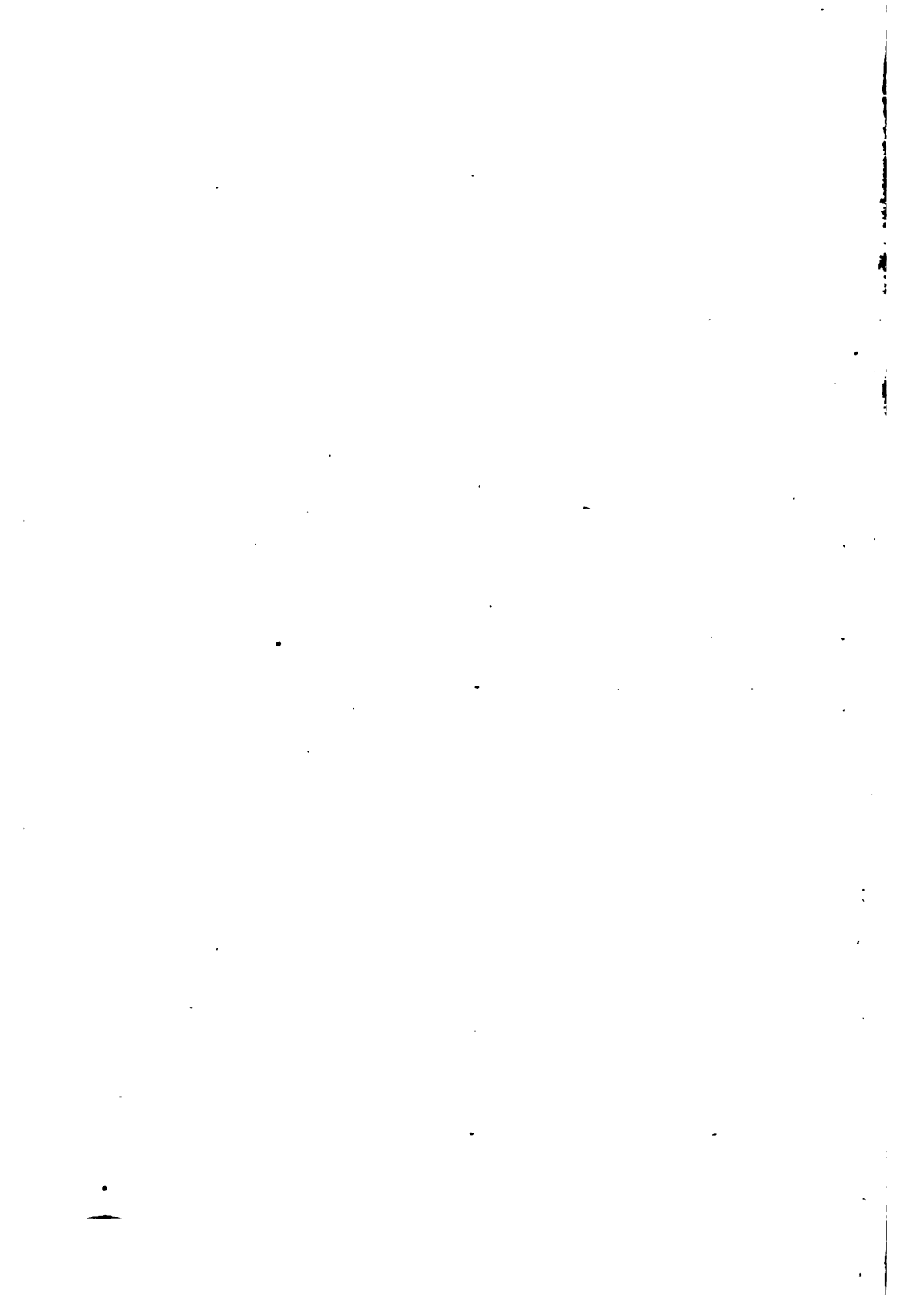

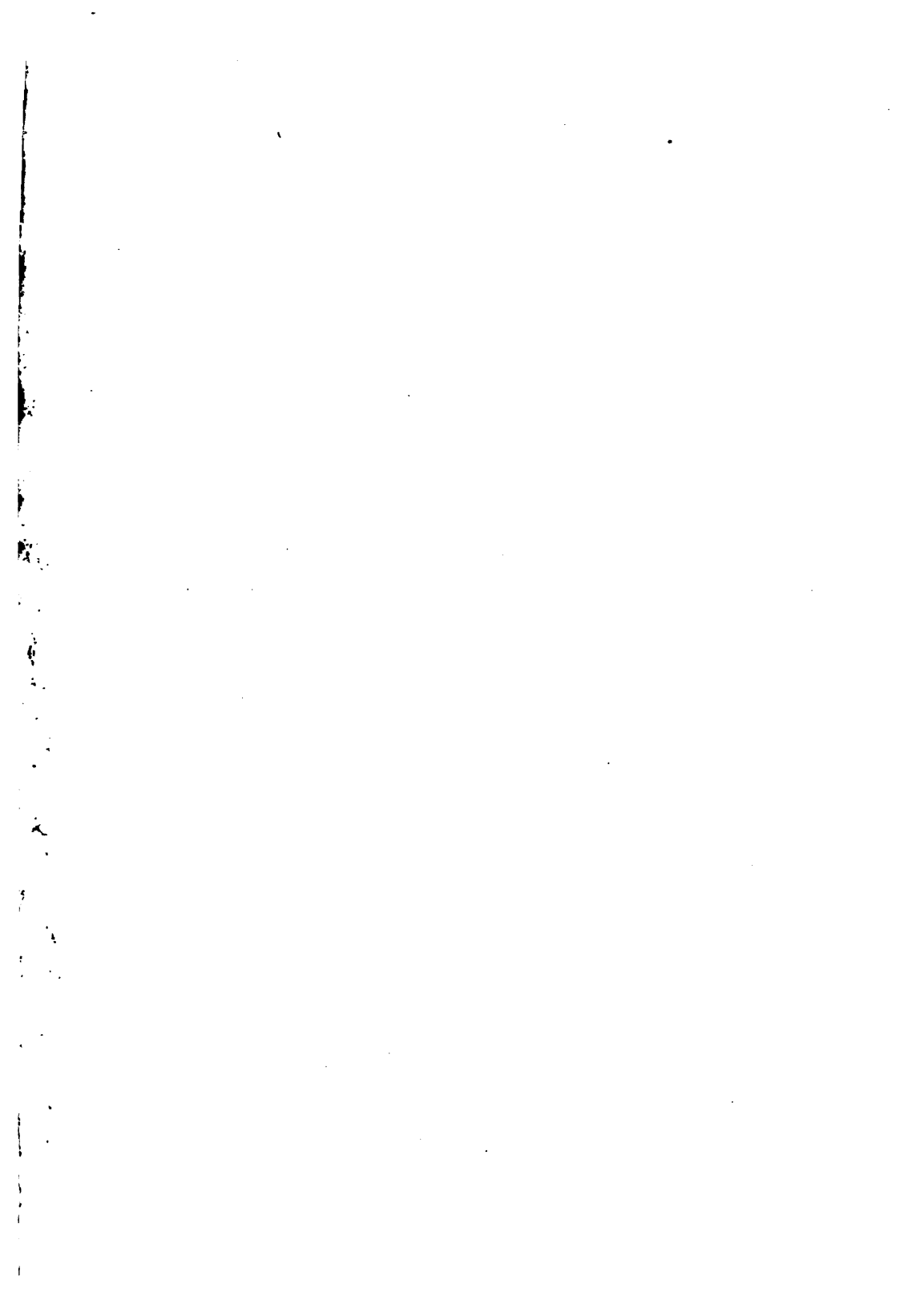

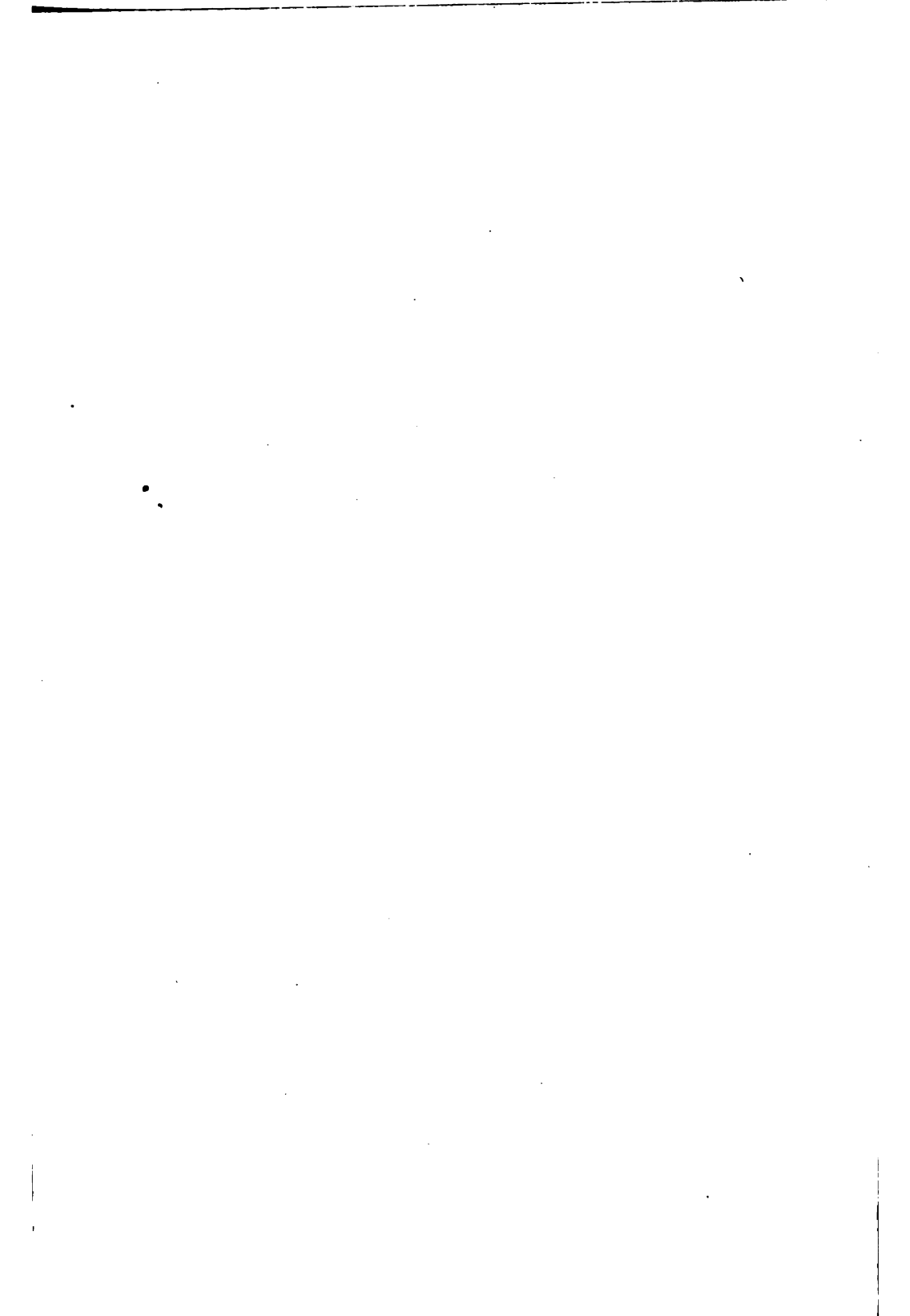

✓

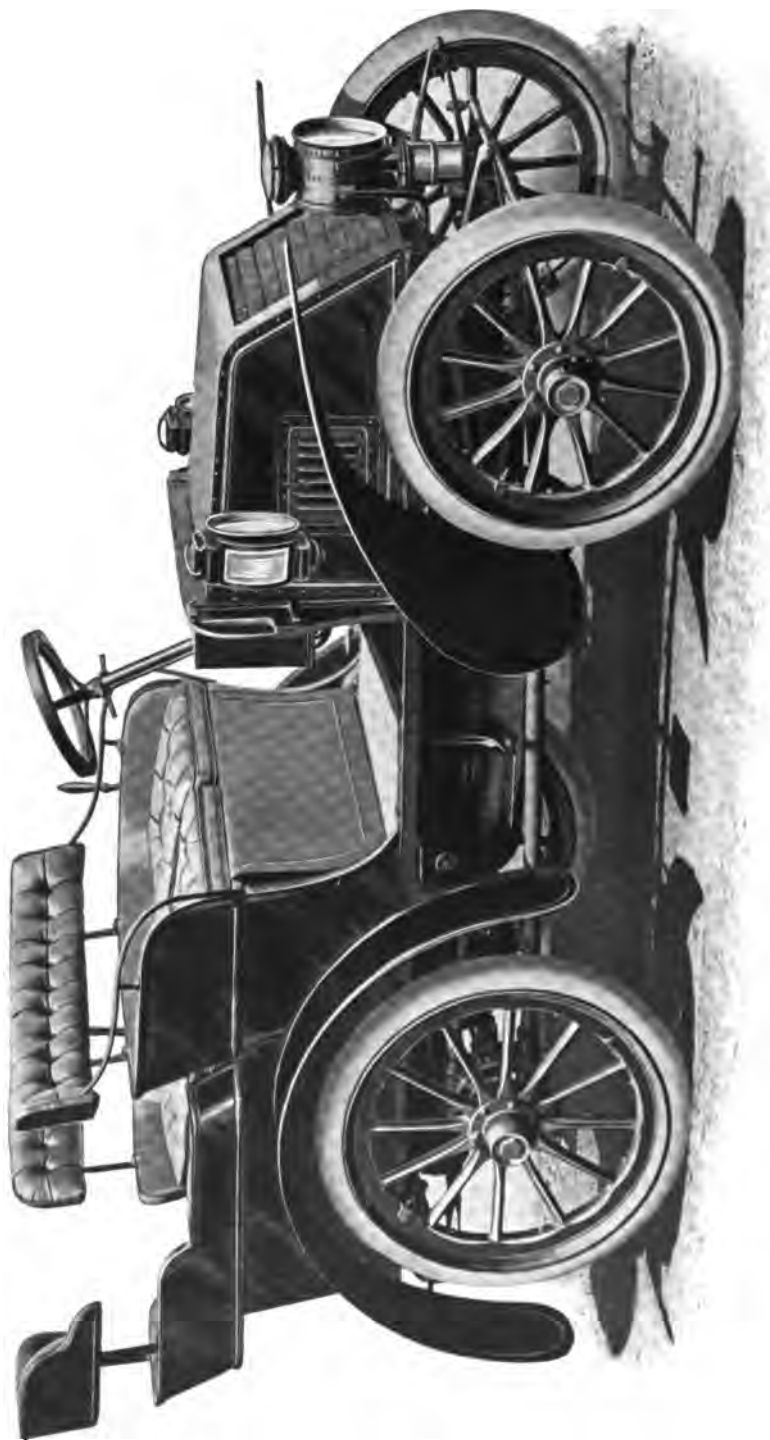

A Typical American Gasoline Carriage. A 16 Horse-Power Tonneau Touring Car.

SELF-PROPELLED VEHICLES

A PRACTICAL TREATISE

BY

EMIL REUTEMANN, CONSTRUCTION, OPERATION, CARE
AND REPAIRMENT

BY THE AUTHOR

AUTOMOBILES

BY

EMIL REUTEMANN, M. E.

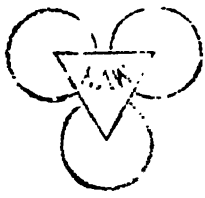

REPRINTED FROM THE "AUTOMOBILE" BY THE AUTHOR, 1907. BY PERMISSION OF THE PUBLISHERS, THE A.S.M. COMPANY, NEW YORK, N. Y.

NEW YORK, U. S. A.
THE A.S.M. COMPANY
125 WEST 47th AVENUE
1907

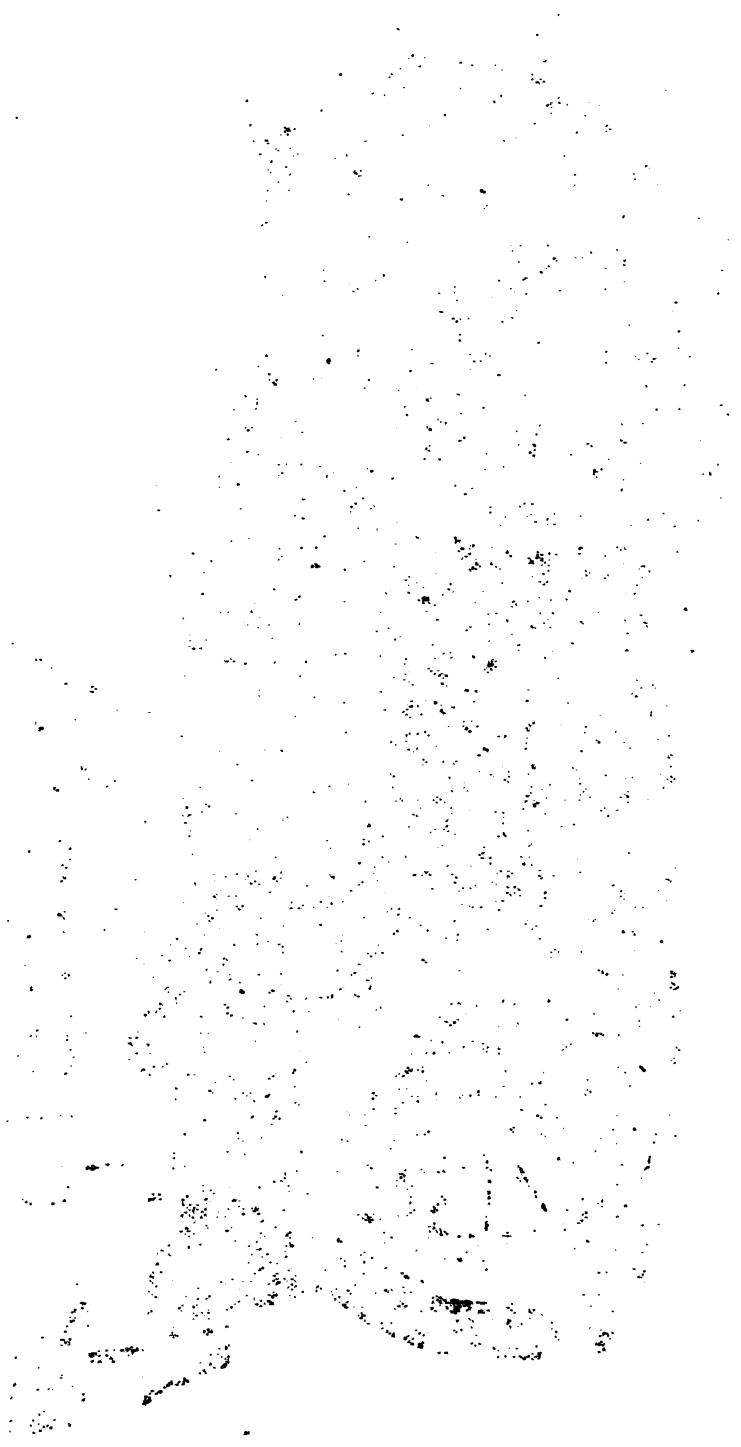

SELF-PROPELLED VEHICLES

A PRACTICAL TREATISE

ON THE

THEORY, CONSTRUCTION, OPERATION, CARE
AND MANAGEMENT

OF ALL FORMS OF

AUTOMOBILES

BY

JAMES E. HOMANS, A. M.

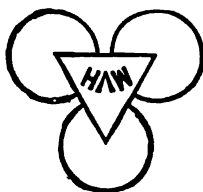

*WITH UPWARDS OF 500 ILLUSTRATIONS AND DIAGRAMS, GIVING THE ESSEN-
TIAL DETAILS OF CONSTRUCTION AND MANY IMPORTANT POINTS ON
THE SUCCESSFUL OPERATION OF THE VARIOUS TYPES OF MOTOR
CARRIAGES DRIVEN BY STEAM, GASOLINE AND ELECTRICITY.*

NEW YORK, U. S. A.

THEO. AUDEL & COMPANY

SIXTY-THREE FIFTH AVENUE

1902

COPYRIGHTED BY
THEO. AUDEL & CO.
1902

70755
MAY 7 1903

6452290

STQ

H75

PREFACE.

Scarcely three years ago it was a comparatively rare occurrence in this country to see a self-propelled vehicle, or "automobile," of any description. To-day they are among the most familiar sights; hundreds of firms are engaged in their manufacture—many of them scarcely able to keep abreast of the demand for machines—while in the popular mind there is a constantly increasing interest in the subject.

Accompanying these phenomena of an industrial development, very nearly unparalleled in its rapid rise to an approximate perfection, we find a corresponding desire for information on the construction and operation of these new masterpieces of skill, which, so it seems, has created a very real demand for just such a treatise as the present volume.

In presenting this book to the public, a few words seem necessary, by way of introduction and explanation. In the first place the treatment of subjects throughout has been kept as nearly as possible in the lines popularly called "non-technical." The various theories and problems involved in the construction and operation of the prevailing types of motor road carriage have been stated as clearly and simply as possible, in order that the involved situations may be readily comprehended by all readers. The fundamental principles of the several types of motor, particularly of the gasoline engine, which is the least understood of all, have been treated at considerable length, in order that the facts may be thoroughly comprehended in their new relations.

It has been the author's aim to state and discuss the most important points of this already immense subject, and to treat only of constructions that have been proven thoroughly practi-

cal. Under either head many things that will, doubtless, be of paramount importance in the near future can only be suggested at the present time.

In the preparation of this work the author has been ably assisted by several persons to whom he desires to render grateful acknowledgments. Mr. Charles E. Duryea, the well-known pioneer of the automobile industry in America, has rendered him very great assistance with numerous suggestions of value and in reading proofs of much of the matter relating to gasoline engines and general construction. Mr. George Perrott, M.E., has, in a number of instances, given him the benefit of his vast experience in mechanical matters, contributing many points of unusual practical interest. Many of the illustrations were prepared, under the author's direction, by Messrs. Francis S. Dixon, Edwin F. Tilley, and Edward Straeffer, whose skill and experience as draughtsmen will greatly illuminate the accompanying descriptions.

CONTENTS.

CHAPTER.	PAGE.
I.—THE NAMES AND VARIETIES OF MOTOR CARRIAGES	1-6
II.—A BRIEF HISTORY OF SELF-PROPELLED VEHICLES	7-18
III.—HOW A MOTOR CARRIAGE TURNS	19-34
IIIa.—STEERING A MOTOR CARRIAGE	35-53
IV.—DEVICES FOR COMBINING STEERING AND DRIVING	54-61
V.—THE UNDERFRAMES OF MOTOR CARRIAGES	62-79
VI.—SPRINGS, RADIUS RODS AND JOINTED SHAFTS	80-93
VII.—MOTOR CARRIAGE WHEELS	94-104
VIII.—SOLID RUBBER TIRES	105-111
IX.—THE USE AND EFFECT OF PNEUMATIC TIRES	112-145
X.—THE THEORY, CONSTRUCTION AND OPERATION OF STEAM BOILERS	147-154
XI.—THE TESTING AND REGULATING ATTACHMENTS OF STEAM BOILERS	155-165
XII.—SMALL SHELL AND FLUE BOILERS FOR STEAM CARRIAGES	166-175
XIII.—OF WATER TUBE BOILERS, AND THEIR USE IN STEAM CARRIAGES	176-199
XIV.—FLASH STEAM GENERATORS	200-211
XV.—BOILER FEEDERS AND WATER LEVEL REGULATORS	212-231
XVI.—LIQUID FUEL BURNERS AND REGULATORS	232-258
XVII.—STEAM AND ITS USE AS A MOTIVE POWER	259-275
XVIII.—CONSTRUCTION AND OPERATION OF A STEAM ENGINE	276-286
XIX.—SIMPLE STEAM CARRIAGE ENGINES	287-301
XX.—SINGLE-ACTING STEAM CARRIAGE ENGINES	302-309
XXI.—COMPOUND STEAM ENGINES	310-325
XXII.—SELF-PROPELLED STEAM FIRE ENGINES	326-329

CHAPTER.	PAGE.
XXIII.—GENERAL PRINCIPLES OF GAS ENGINE OPERATION	331-343
XXIV.—THE PRESSURE, TEMPERATURE AND VOLUME OF GASES IN A GAS ENGINE	344-355
XXV.—THE METHODS AND CONDITIONS OF GAS ENGINE CYLINDER COOLING	356-369
XXVI.—CONDITIONS RESULTING FROM COMBUSTION OF THE FUEL CHARGE	370-384
XXVII.—GAS ENGINE EFFICIENCY	385-395
XXVIII.—ESTIMATING THE HORSE-POWER OF GAS ENGINES	396-405
XXIX.—ON CARBURETTERS AND VAPORIZERS	406-423
XXX.—ON THE METHODS OF FIRING THE CHARGE	424-450
XXXI.—TRANSMISSION GEARS AND SPEED-CHANGING DEVICES	451-473
XXXII.—DEVELOPMENT OF GASOLINE VEHICLES BY DAIMLER AND HIS SUCCESSORS	475-492
XXXIII.—THE DE DION CARRIAGE AND MOTOR	493-501
XXXIV.—SOME PROMINENT AMERICAN GASOLINE CARRIAGES	503-521
XXXV.—SOME RECENT AMERICAN GASOLINE CARRIAGES	522-536
XXXVI.—GENERAL PRINCIPLES OF ELECTRICITY	537-545
XXXVII.—CONSTRUCTION OF THE DYNAMO ELECTRICAL GENERATOR AND MOTOR	546-554
XXXVIII.—OPERATION OF ELECTRICAL GENERATORS AND MOTORS	555-565
XXXIX.—METHODS OF CIRCUIT-CHANGING IN ELECTRIC VEHICLES	566-576
XL.—CONSTRUCTION AND OPERATION OF STORAGE BATTERIES	577-589
XLI.—CONSTRUCTION AND OPERATION OF BRAKES	590-596
XLII.—ON BALL AND ROLLER BEARINGS	597-602
XLIII.—ON THE NATURE AND USE OF LUBRICANTS	603-606
XLIV.—HINTS ON STEAM VEHICLE MANAGEMENT	607-612
XLV.—HINTS ON GASOLINE VEHICLE MANAGEMENT	613-620





GOTTLIEB DAIMLER

(1834-1899)

**INVENTOR OF THE PRACTICAL HIGH-SPEED GASOLINE MOTOR
AND
"FATHER OF THE AUTOMOBILE"**

SELF-PROPELLED VEHICLES.

A PRACTICAL TREATISE.

CHAPTER ONE.

THE NAMES AND VARIETIES OF MOTOR CARRIAGES.

Automobile, Locomobile, or Motor Carriage?—The widespread interest in the subject of horseless vehicles propelled by motors seems to have determined that the word, *automobile*, shall be permanently adopted into the English language. This being the case, it is useless to attempt to change the usage or propose any other generic term to describe a “self-moving,” or motor-driven, carriage. To be exact, however, the word is not properly derived, according to the rules of rhetoric, being a compound of the words, *autos*, self, and, *mobilis*, moving, the first Greek, the second Latin. The best authorities assert that all the elements in a compound word should properly be derived from the same language, if it be composed of words other than English. According to this rule, the word, “locomobile,” from the words *locus*, place, and, *mobilis*, moving, both Latin, is undoubtedly a more correct term. But since this word seems to have been preëmpted as the designation for an excellent type of American steam carriage, and it seems impossible to find any other euphonious word with the meaning of “self-mover,” there is likely no alternative but to submit to current usage, and call the motor carriage of any type, “automobile.”

Special Designations for Motor Carriages.— Since there is a wide variety of vehicles, from the two-ton road wagon to the motor bicycle, to come under the general head of “automobile,” and since this word will soon have a far more general significance

than at present, a number of special designations, many of them combinations of the word, "mobile," have been invented within recent years. Thus it has been widely proposed to call a vehicle propelled by electricity an "electromobile," which term is in actual use by several manufacturers. Also the word, "gasmobile,"



FIG. 1.—A Light Two-Passenger Phaeton, propelled by a Gasoline Motor.

is used as the name of at least one make of gasoline motor carriage; while "steamobile" is quite as widely known in connection with an excellent make of steam carriage. Such words as "automotor," "auto-car," "auto-truck," "auto-carriage," "auto-cycle," and the like are widely exploited by others, either as general



FIG. 2.—A Gasoline Motor Bicycle.

terms or special designations. On the other hand, when speaking of some particular style of power-driven carriage it seems to be the more general usage to speak of an "electric brougham," a "gasoline runabout," a "steam stanhope," than to use any of the

names mentioned above. The words "motor bicycle," "motor cycle," "motor surrey," etc., are also used.

The Common Sense Name.—Like most other mooted questions, the matter of names for motor carriages reduces itself to one of common sense, purely. While any of the names given above, and several others also, may be perfectly correct rhetorically or philologically, or be able to influence usage sufficiently

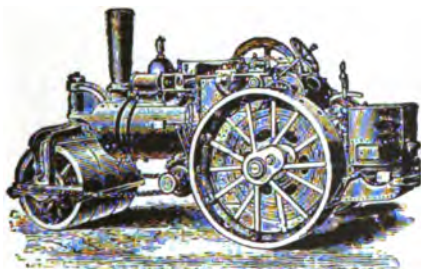

FIG. 3.—A Self-Propelling Steam Road Roller of Ordinary Pattern.

to compel their ultimate adoption, the development of the motor vehicle industry in the future, when the horse carriage will undoubtedly become the exception, demands that some definite idea be conveyed by each word used. Thus, when the ordinary citizen hears the word, "Locomobile," as applied to the special



FIG. 4.—A Two-Ton Steam Road Wagon, or Lorry.

make of steam carriage claiming that title, he at once thinks of a four-wheeled, steam-driven vehicle with a "runabout" body, manufactured by the Locomobile Co. of America. This fact the manufacturers themselves recognize, when they speak in their

SELF-PROPELLED VEHICLES.

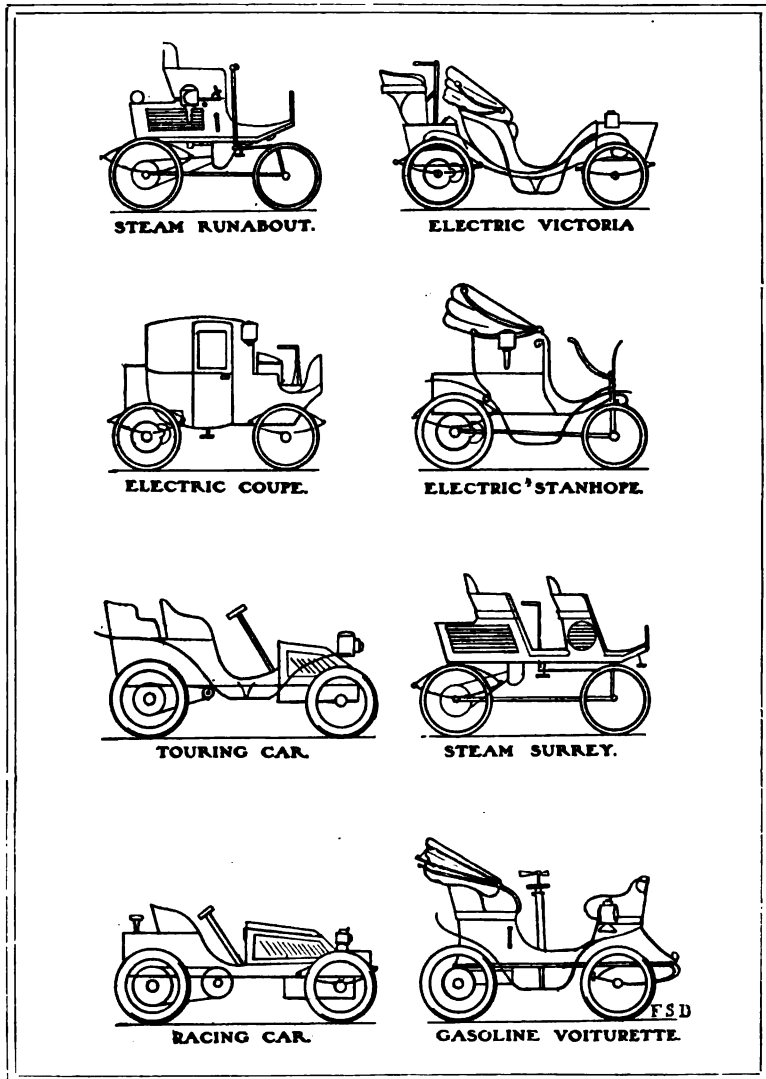

FIG. 5.—Eight Well-known Types of Self-Propelled Road Vehicles.

advertisements and announcements of their "Loco-surrey," which is built to a different design. Other ordinary citizens, those possessing a fine sense of discrimination, will frequently attempt to explain to admiring auditors the difference between a "locomobile" and an "automobile," generally asserting that the former word means a steam carriage, and the latter a gasoline carriage. But, when asked about the word for an electric carriage, they will be quite at a loss, unless the words "electro-

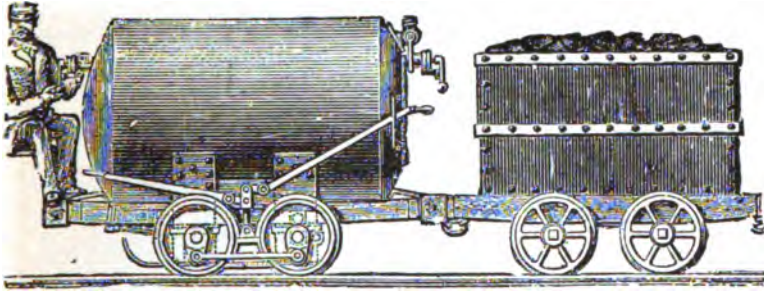

FIG. 6.—A Compressed Air Locomotive, such as 'is used in English mines, with car attached.

mobile" or electrobat"—the latter is an English contribution to the growing vocabulary—have reached their understandings. As a matter of fact, no such distinctions exist, either in the words themselves or in their usage, and attempts to discuss the point merely waste time. At the present stage of the industry the name of the firm or corporation manufacturing motor carriages is of interest to the public, just as was the case formerly with sewing machines and bicycles. The time will undoubtedly come when none but experts will discriminate particularly between the several efficient makes of carriage, any more than the average man now stops to remark that his horse carriage is a Brewster, a Bailey, a Miller, or any other special make, being perfectly satisfied if it runs with small care and light wear. The time will also probably come when we shall speak of steam surreys, gasoline runabouts, electric phaetons, etc., etc., leaving the name of the maker as the answer to a possible question, and omitting altogether any remarks tinged with "auto," "loco," "mobile" or "bat." The

broadest terms, therefore, will be undoubtedly "motor carriage," "motor wagon," or "motor cycle," the specific information being given by telling the kind of carriage, wagon or cycle, and the kind of motor. For when we use the word "automobile," we have a word that does not necessarily include the others. It is a term precisely like "locomotive"—indeed, we must not forget the fact that an automobile is properly a kind of locomotive—and, while we actually speak of "steam locomotives," "electric loco-

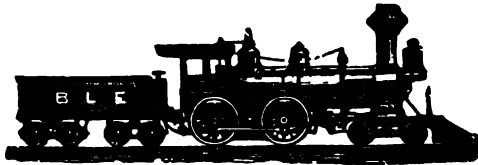

FIG. 7.—A Common Type of Eight-wheeled Passenger Locomotive.



FIG. 8.—A Ten-wheeled Freight Locomotive.

motives," or "compressed air locomotives," we must specify further in order to tell whether it be for passenger, freight or switching service, or whether it be a four-wheeler, a "pony," a "dummy," a "decapod," or into what class it falls, according to its use or design. "Automobile," therefore, merely designates a conveyance which neither runs on a railroad track, nor yet is drawn by a horse. The only warrant it has for a place in the language is in the fact that the prevailing form of vehicle on ordinary roadways is horse-drawn, and not motor-driven. What term will we use when the situation is reversed? Surely, it will be some analogy to the present usage, wherein we speak of seeing a friend driving his bay mare to his top buggy, or giving his family an outing in his surrey and grey team. For by one word we indicate the style of vehicle, and by the other, the motive-power employed.

CHAPTER TWO.

A BRIEF HISTORY OF SELF-PROPELLED ROAD VEHICLES.

Requirements for a Successful Motor Carriage.—Even before the days of successful railroad locomotives several inventors had proposed to themselves the problem of a steam-propelled road wagon, and actually made attempts to build machines to embody their designs. In 1769 Nicholas Joseph Cugnot, a captain in the French army, constructed a three-wheeled wagon, having the boiler and engine overhanging, and to be turned with the forward wheel, and propelled by a pair of single-acting cylinders, which worked on ratchets geared to the axle shaft. It was immensely heavy, awkward and unmanageable, but succeeded in making the rather unexpected record of two and a half miles per hour, over the wretched roads of that day, despite the fact that it must stop every few hundred feet to steam up. Later attempts in the same direction introduced several of the essential motor vehicle parts used at the present day, and with commensurately good results. But the really practical road carriage cannot be said to have existed until inventors grasped the idea that the fuel for the engines must be something other than coal, and that, so far as the boilers and driving gears are concerned, the minimum of lightness and compactness must somehow be combined with the maximum of power and speed. This seems a very simple problem, but we must recollect that even the simplest results are often the hardest to attain. Just as the art of printing dates from the invention of an inexpensive method of making paper, so light vehicle motors were first made possible by the successful production of liquid or volatile fuels.

In addition to this, as we shall presently understand, immense contributions to the present successful issue have been made by pneumatic tires, stud steering axles and balance gears, none of which were used in the motor carriages of sixty and eighty years ago. So that, we may confidently insist, although many thoughtless persons still assert that the motor carriage industry is in its infancy, and its results tentative, we have already most of the

elements of the perfect machine, and approximations of the remainder. At the present time the problem is not on what machine can do the required work, but which one can do it best.

A Brief Review of Motor Carriage History.—As might be readily surmised, the earliest motor vehicles were those propelled by steam engines, the first attempt, that of Capt. Cugnot, dating, as we have seen, from 1769-70. In the early years of the nineteenth century, and until about 1840-45, a large number of steam

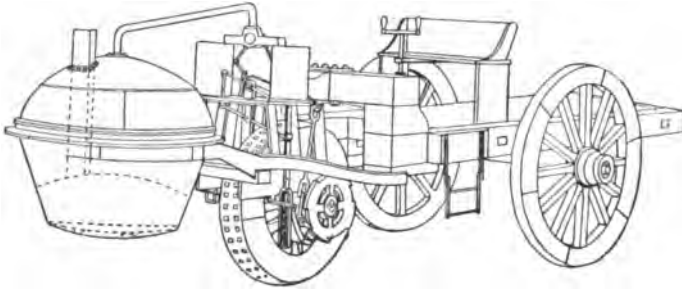

FIG. 9.—Captain Cugnot's Three-wheel Steam Artillery Carriage (1769-70). This cut shows details of the single flue boiler and of the driving connections.

carriages and stage coaches were designed and built in England, some of them enjoying considerable success and bringing profit to their owners. At about the close of this period, however, strict laws regarding the reservation of highways to horse-vehicles put an effectual stop to the further progress of an industry that was already well on its way to perfection, and for over forty years little was done, either in Europe or America, beyond improving the type of farm tractors and steam road rollers, with one or two sporadic attempts to introduce self-propelling steam fire engines. During the whole of this period the light steam road carriage existed only as a pet hobby of ambitious inventors, or as a curiosity for exhibition purposes. Curiously enough, while the progress of railroad locomotion was, in the meantime, rapid and brilliant, the re-awakening of the motor carriage idea and industry, about 1885-89, was really the birth of a new science of constructions, very few of the features of former carriages being then adopted. In 1885 Gottlieb Daimler patented his high-speed gas or mineral spirit engine, the parent and prototype of the wide

variety of explosive vehicle motors since produced, and, in the same year, Carl Benz, of Mannheim, constructed and patented his first gasoline tricycles. The next period of progress, in the years immediately succeeding, saw the ascendancy of French engineers, Peugeot, Panhard, De Dion and Mors, whose names, next to that of Daimler himself, have become common-places with all who speak of motor carriages. In 1889 Leon Serpollet, of Paris, invented his famous instantaneous, or "flash," generator, which was, fairly enough, the most potent agent in restoring the steam engine to consideration as means of motor

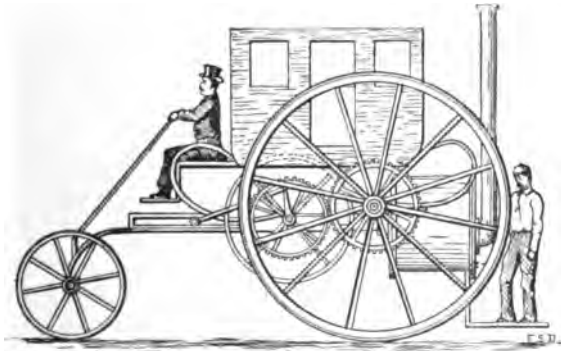

FIG. 10.—Richard Trevithick's Steam Road Carriage (1802). The centre-pivoted front axle is about half the length of the rear axle. The cylinder is fixed in the centre of the boiler. The engine has a fly-wheel and spur gear connections to the drive axle.

carriage propulsion. Although it has not become the prevailing type of steam generator for this purpose, it did much to turn the attention of engineers to the work of designing high-power, quick-steaming, small-sized boilers, which have been brought to such high efficiency, particularly in the United States. With perfected steam generators came also the various forms of liquid or gas fuel burners. The successful electric carriage dates from a few years later than either of the others, making its appearance as a practical permanency about 1893-94.

Trevithick's Steam Carriage.—In reviewing the history of motor road vehicles we will discover the fact that the attempts which were never more than plans on paper, working models, or downright failures are greatly in excess of the ones even half-

way practical. From within a few years after Cugnot's notable attempt and failure, many inventors in England, France and America appeared as sponsors for some kind of a steam road carriage, and as invariably contributed little to the practical solution of the problem. In 1802 Richard Trevithick, an engineer of ability, subsequently active in the work of developing railroad cars and locomotives, built a steam-propelled road carriage, which, if we may judge from the drawings and plans still extant, was altogether unique, both in design and operation. The body was supported fully six feet from the ground, above rear driving wheels of from eight to ten feet in diameter, which, turning loose on the axle trees, were propelled by spur gears secured to the hubs. The cylinder placed in the centre of the boiler turned its crank on the counter-shaft, just forward of the axle, and imparted its motion through a second pair of spur gears, meshing with those attached to the wheel hubs. The steering was by the forward wheels, whose axle was about half the width of the vehicle, and centre-pivoted, so as to be actuated by a hand lever rising in front of the driver's seat. This difference in the length of the two axles was probably a great advantage to positive steering qualities, even in the absence of any kind of compensating device on the drive shaft. The carriage was a failure, however, owing to lack of financial support, as is alleged, and, after a few trial runs about London, was finally dismantled.

Gurney's Coaches.—The Golden Age of steam coaches extended from the early twenties of the nineteenth century for about twenty years. During this period much was done to demonstrate the practicability of steam road carriages, which for a time seemed promising rivals to the budding railroad industry. Considerable capital was invested and a number of carriages were built, which actually carried thousands of passengers over the old stage-coach roads, until adverse legislation set an abrupt period to further extension of the enterprise. Among the names made prominent in these years is that of Goldsworthy Gurney, who, in association with a certain Sir Charles Dance, also an engineer, constructed several coaches, which enjoyed a brief though successful career. His boiler, like those then used in the majority of carriages, was of the water-tube variety, and in many respects

closely resembled some of the most successful styles made at the present day. It consisted of two parallel horizontal cylindrical drums, set one above the other in the width of the carriage, surmounted by a third, a separator tube, and connected together by a number of tubes, each shaped like the letter U laid on its side, and also, directly, by several vertical tubes. The fire was applied to the lower sides of the bent tubes, under forced draught, thus creating a circulation, but, on account of the small heating surface, the boiler was largely a failure. Mr. Dance did much

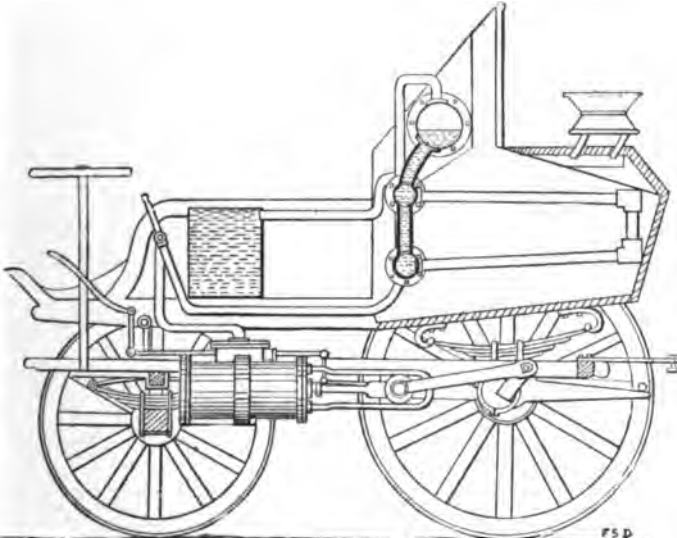

FIG. 11.—Sectional Elevation of one of Goldsworthy Gurney's Early Coaches, showing water tube boiler, directly geared cylinders and peg-rod driving wheel.

to remedy the defects of Gurney's boiler with a water-tube generator, designed by himself, in which the triple rows of parallel U-tubes were replaced by a number of similarly-shaped tubes connected around a common circumference by elbow joints, and surmounted by dry steam tubes, thus affording a much larger heating surface for the fire kindled above the lower sides of the bent tubes. Gurney's engine consisted of two parallel cylinders, fixed in the length of the carriage and operating cranks on the revolving rear axle shaft. The wheels turned loose on the axles, and were driven by double arms extending in both directions

from the axle to the felloe of the wheel, where they engaged suitably arranged bolts, or plugs. On level roadways only one wheel was driven, in order to allow of turning, but in ascending hills both were geared to the motor, thus giving full power. In Gurney's later coaches and tractors the steering was by a sector,

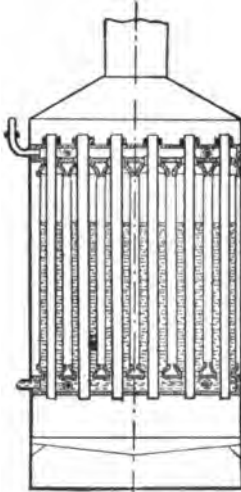

FIG. 12.

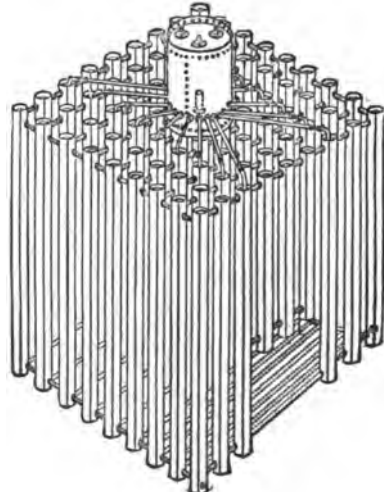

FIG. 13.

FIGS. 12-13.—Improved Boilers for Gurney Coaches; the first by Summers & Ogle; the second by Maceroni & Squire.

with its centre on the pivot of the swinging axle shaft and operated by a gear wheel at the end of the revolving steering post. In one of his earliest carriages he attempted the result with an extra wheel forward of the body and the four-wheel running frame, the swinging forward axle being omitted, but this arrangement speedily proving useless, was abandoned.

Improvements on Gurney's Coaches.—Several other builders, notably Maceroni and Squire, and Summers and Ogle, adopted the general plans of Gurney's coaches and driving gear, but added improvements of their own in the construction of the boilers and running gear. The former partners used a water-tube boiler consisting of eighty vertical tubes, all but eighteen of which were connected at top and bottom by elbows or stay-tubes, the others being extended so as to communicate with a

central vertical steam drum. Summers and Ogle's boiler consisted of thirty combined water tubes and smoke flues, fitting into square plan, flat vertical-axis drums at top and bottom. Into each of these drums—the one for water, the other for steam—the water tubes opened, while through the top and bottom plates, through the length of the water-tubes, ran the contained smoke flues, leading the products of combustion upward from the furnace. The advantage of this construction was that considerable water could be thus heated, under draught, in small tube sections, while the full effect of 250 square feet of heating surface was realized. With both these boilers exceedingly good results were obtained, both in efficiency and in small cost of operation. Indeed, the reasonable cost of running these old-time steam carriages is surprising. It has been stated that Gurney and Dance's coaches required on an average about 4d. (eight cents) per mile for fuel coke, while the coaches built by Maceroni and Squire often averaged as low as 3d. (six cents). The average weight of the eight and ten-passenger coaches was nearly 5,000 pounds, their speed, between ten and thirty miles, and the steam pressure used about 200 pounds.

Hancock's Coaches.—By all odds the most brilliant record among the early builders of steam road carriages is that of Walter Hancock, who, between the years 1828 and 1838, built nine carriages, six of them having seen actual use in the work of carrying passengers. His first effort, a three-wheeled phaeton, was driven by a pair of oscillating cylinders geared direct to the front wheel, and being turned on the frame with it in steering. Having learned by actual experiment the faults of this construction, he adopted the most approved practice of driving on the rear axle, and in his first passenger coach, "The Infant," he attached his oscillating cylinder at the rear of the frame, and transmitted the power by an ordinary flat-link chain to the rotating axle. He was the first to use the chain transmission, now practically universal. As he seems to have been a person who readily learned by experience, he soon saw that the exposure of his engines to dust and other abrasives was a great source of wear and disablement; consequently in his second coach, "Infant No. 2," he supplanted the oscillating cylinder hung outside by a slide-valve

cylinder and crank disposed within the rear of the coach body above the floor. In this and subsequent carriages he used the chain drive, also operating the boiler feed pump from the cross-head, as in most steam carriages at the present day.

Hancock's boiler was certainly the most interesting feature of his carriages, both in point of original conception and efficiency in steaming. It was composed of a number of flat chambers—"water bags" they were called—laid side by side and intercommunicating with a water drum at the base and steam drum at the top. Each of these chambers was constructed from a flat sheet of metal, hammered into the required shape and flanged along the edges, and, being folded together at the middle point,

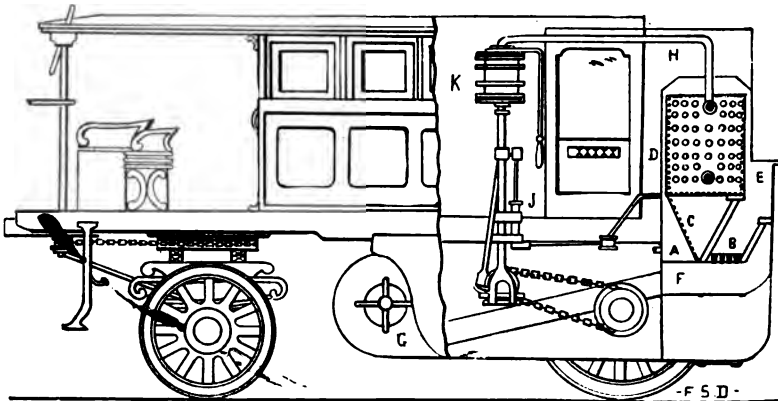

FIG. 14.—Part section of one of Hancock's Coaches, showing Engine and Driving Connections. A is the exhaust pipe leading steam against the screen, C, thence up the flue, D, along with smoke and gases from the grate, B. E is the boiler; H the out-take pipe; K the engine cylinder and, J, the water-feed pump; G is a rotary fan for producing a forced draught, and F the flue leading it to the grate.

the two halves were securely riveted together through the flanged edge. The faces of each plate carried regularly disposed hemispherical cavities or bosses, which were in contact when the plates were laid together, thus preserving the distances between them and allowing space for the gases of combustion to pass over an extended heating surface. The high quality of this style of generator may be understood when we learn that, with eleven such chambers or "water bags," 30 x 20 inches x 2 inches in thickness and 89 square feet of heating surface to 6 square feet of grate, one effective horse-power to every five square feet was

realized, which gives us about eighteen effective horse-power for a generator occupying about 11.1 cubic feet of space, or 30 x 20 x 32 inches.

The operation of the Hancock boiler is interesting. The most approved construction was to place the grate slightly to the rear of the boiler's centre, and the fuel, coke, was burnt under forced draught from a rotary fan. The exhaust steam was forced into the space below the boiler, where a good part of it, passing through a finely perforated screen, was transformed into water gas, greatly to the benefit of perfect combustion.

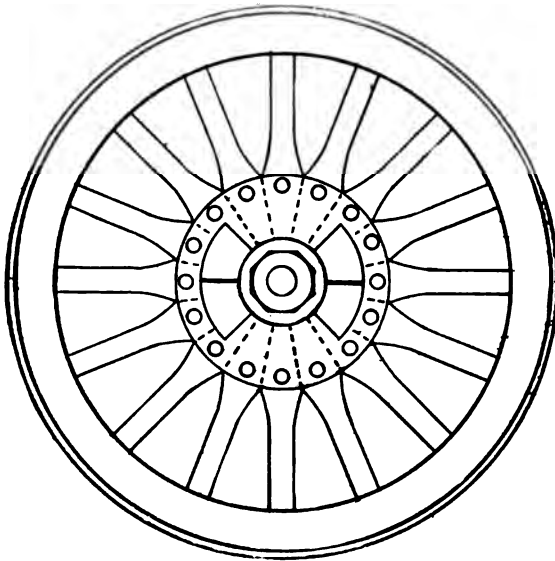

FIG. 15.

FIG. 15.—Hancock's Wedge Drive Wheel, showing wedge spokes and triangular driving lugs at the nave.



FIG. 16.

FIG. 16.—One element of the Hancock Boiler, end view.

As early as 1830 Hancock devised the "wedge" wheels, since so widely adopted as models of construction. As shown in the accompanying diagram, his spokes were formed, each with a blunt wedge at its end, tapering on two radii from the nave of the wheel; so that, when laid together, the shape of the complete wheel was found. The blunt ends of these juxtaposed wedges rested upon the periphery of the axle box, which carried a flange,

or vertical disk, forged in one piece with it, so as to rest on the inside face of the wheel. This flange was pierced at intervals to hold bolts, each penetrating one of the spokes, and forming the "hub" with a plate of corresponding diameter nitted upon the outer face of the wheel. The through axle shaft, formed in one piece and rotatable, carried secured to its extremities, when the wheel was set in place, two triangular lugs, oppositely disposed and formed on radii from the nave. The outer hub-plate carried

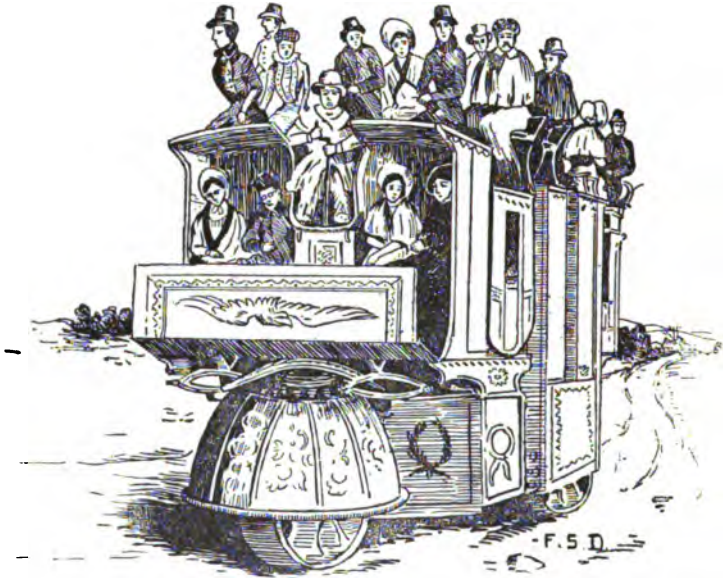

FIG. 17.—Church's Three-wheel Coach (1833), drawn from an old woodcut, showing forward spring wheel mounted on the steering pivot.

similarly shaped and disposed lugs, and the driving was effected by the former pair, turning with the axle spindle, engaging the latter pair, thus combining the advantages of a loose-turning wheel and a rotating axle. Through nearly half of a revolution also the wheel was free to act as a pivot in turning the wagon, thus obtaining the same effect as with Gurney's arm and pin drive wheels. The prime advantage, however, was that the torsional strain was evenly distributed through the entire structure by virtue of the contact of the spoke extremities.

Other Notable Coaches.—According to several authorities, only Gurney, Hancock and J. Scott Russell built coaches that saw even short service as paying passenger conveyances—one of the latter's coaches was operated occasionally until about 1857. There were, however, numerous attempts and experimental structures, all more or less successful, which deserve passing mention as embodying some one or another feature that has become a permanence in motor road carriages or devices suggestive of such features. A coach built by a man named James, about 1829, was the first on record to embody a really mechanical device for al-



FIG. 18.—James' Coach (1829), the "first really practical steam carriage built." Drawn from an old wood cut.

lowing differential action of the rear, or driving, wheels. Instead of driving on but one wheel, as did Gurney, or using clutches, like some others, he used separate axles and four cylinders, two for each wheel, thus permitting them to be driven at different speeds. This one feature entitles his coach to description as the "first really practical steam carriage built." Most of the others, if the extant details are at all correct, must have been, except on straight roads, exceedingly unsatisfactory machines at best. According to the best information on the subject, a certain Hills, of Deptford, was the first to design and use on a carriage, in 1843, the compensating balance gear, or "jack in the box," as it was then called, which has since come into universal use on motor vehicles of all descriptions. As for rubber tires, although a certain Thompson is credited with devising some sort of inflatable device of this description about 1840-45, there seems to have

been little done in the way of providing a springy, or resilient, support for the wheels. We have, however, some suggestion of an attempt at spring wheels on Church's coach, which was built in 1833. According to an article in the *Mechanics' Magazine* for January, 1834, which gives the view of this conveyance, herewith reproduced, "The spokes of the wheels are so constructed as to operate like springs to the whole machine—that is, to give and take according to the inequalities of the road." In other respects the vehicle seems to have been fully up to the times, but, judging from its size and passenger capacity, as shown in the cut, it is reasonable to suppose that the use of spring wheels was no superfluous ornamentation. If we may judge further from the cut, the wheels had very broad tires, thus furnishing another element in the direction of easy riding on rough roads.



CHAPTER THREE.

HOW A MOTOR CARRIAGE TURNS.

Modern Motor Vehicles.— Like other achievements of modern science and industry, the motor vehicle is the resultant of a long series of brilliant inventions and improvements in several directions. Successful motor carriages, as now constructed, are of three varieties, according to the motive power employed: those propelled by steam; those propelled by explosive motors, gas or oil engines; those propelled by electricity. Considerable has also been done in the direction of producing efficient compressed air motors, which have been actually applied to the propulsion of heavy road wagons and street railway cars, but for light carriage service small results have thus far been attained. Some inventors have expended their energies in other directions, and several patents have been granted in the United States for coiled spring and clockwork motors, and even for carriages carrying masts and sails. We are not concerned, however, with such eccentric devices; the aim of this book being merely the discussion and explanation of successful, practical methods actually applied in the construction and operation of light motor carriages.

Conditions of Automobile Construction.—In one way the automobile has a history very like that of the railway carriage. At the first inception both were devised as suitable substitutes for the horse-drawn vehicle, and, as a consequence, began by following certain traditions of construction, which have proved very like hindrances to progress. The first railway passenger coaches were no more nor less than ordinary road wagons, several being coupled together, so as to be drawn along a grooved tramway. Later, with the introduction of flanged wheels and heavier constructions, a number of carriage bodies were mounted on the same running trucks, which gave the familiar compartment coaches with *vis-a-vis* seats, still used in England and most of the countries of Continental Europe. Only when the theory of

railway car construction departed entirely from the models and traditions of road wagons in the invention and adoption of the American passenger coach, did the day of real progress and comfortable travel begin. In similar fashion, it may be safely asserted, many of the greatest constructional problems of automobiles are to be traced to the tradition of building motor carriages as nearly like horse-drawn vehicles as possible. It seems that the most popular designs of such vehicles are those which appear to be horse-carriages in all respects except that they lack the ordinary shafts or poles for hitching the horses. These

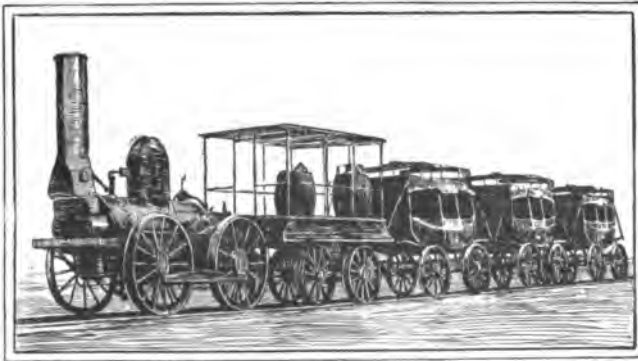

FIG. 19.—Early American Railroad Train (1834), showing passenger coaches, which are simply transformed road stages.

structural problems are, however, real problems, and with both railway coaches and automobiles the adoption of traditional models has been only the following of the best available designs.

Problems in Automobile Construction.—In a horse-drawn vehicle the tractive power, the harnessed horse, is applied at the front and is separate from the carriage or wagon itself. Therefore, the only thing needful is to so construct the frame and running gear as to offer the smallest resistance either in straight-ahead travel or turning. As is well known, each running wheel of a horse carriage is made with a pierced hub and hollow axle box or bearing, so as to be slipped over the end of the axle-bar and secured in place by a nut. The axle-bar of the rear wheels is continuous and rigid with the frame, being attached to the springs

supporting the body. The axle-bar of the forward wheels is also continuous from side to side, but, instead of being bolted to the rest of the frame, is geared to a structure commonly called the "fifth wheel," a horizontal flat wheel or "circle iron," secured to the base of the forward spring, and sliding on another similar segment on the top of the axletree; the two being pivot-bolted at the centre, so as to allow the forward wheels to "cut under" the vehicle, and turn the wagon on any radius its length and weight will permit. Were it practicable in all cases to apply the motive power to the pivoted-axle forward wheels, this same plan of construction would be as good for automobiles as for horse carriages.

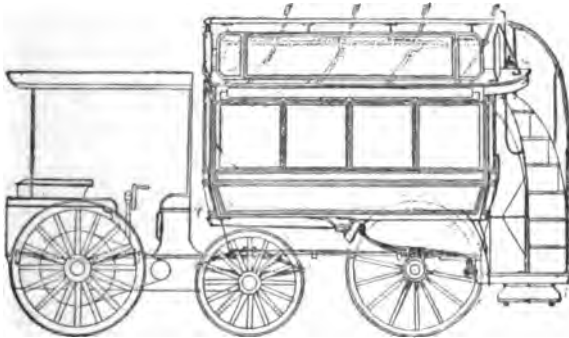

FIG. 20.—A Mechanical Horse—the Carmont Tractor—Intended to be attached to any form of horse-drawn vehicle at the turn-table, or "fifth wheel." It is steered by its rear wheels and drives on the forward pair.

But such a thing is impossible unless we employ either a separate motor truck—a mechanical horse, in fact—or some yet undiscovered method of power-transmission gear. This is the first constructional problem, and a moment's serious reflection will reveal the involved difficulties.

Imitations of Horse Traction.—Curiously enough, in the very first road locomotive ever made—that of Nicholas Cugnot—a desperate attempt was made to meet and solve the difficulty of combining power-traction with free turning attachments. As we have learned, Captain Cugnot employed a single pivoted forward wheel, which was geared rigid to one frame with his engine and boiler, the whole motor-structure turning with every effort to steer the wagon around a corner. He saw readily

enough that to attach the boiler to the frame of the carriage would involve the difficulties and complications incident on telescopic, or extensile, steam connections between boiler and engine, which would, likely, have caused serious trouble. He adopted, therefore, the readiest expedient. His wagon worked very well on a straight road, but developed the disagreeable qualities of "ending up" at every corner, and of refusing to "obey its helm" whenever a stone wall, or other obstruction, made a collision convenient. Had he slung his boiler at the rear of the forward wheel, on the floor of the wagon, he might have overcome the tendency to "top-heaviness" and solved the problem of motor road traction a century sooner.

Present - Day Construction. — Practically all present-day motor carriages have the power applied to the rear wheels, doing the steering with the forward pair. This plan, of course, involves several serious problems, the foremost of which is as to how a carriage can turn a corner, long or short, with both wheels moving at the same rate of speed. If anyone will observe the rear wheels of a carriage in the act of turning, he will see that the one, the pivot wheel, does not revolve or revolves very slowly, as the radius of the described arc be shorter or longer; while the other wheel carries the vehicle around with it. Now, if the power is to be applied to the wheels, either by chain and sprocket, by spur gears or by a crank, either one of six devices must be adopted: (1) The power may be applied equally to both wheels, as in railway locomotives, in which case only turns of very long radius could be made. This is the reason why the curves of railroads are seldom made on a radius of less than three-eighths of a mile (1,980 feet), although, since the steel rails offer immensely less resistance to the wheels than an ordinary road bed, often allowing the drivers to revolve without progressing, there is much smaller need of devices for equalizing or compensating the motions of the pairs. If, then, an automobile can always have a ten-acre lot or a 200-foot road to turn in, it may be able to drive on the locomotive plan: under ordinary conditions it must speedily smash something and come to grief. (2) The motive power may be applied to one wheel of a pair and not to the other, either or both turning loose on the axles. But such a plan would

not only give the carriage a constant tendency to "lurch," rendering forward movement exceedingly difficult, but it would allow turning in only one direction, except on extremely long curves. (3) There may be two separate motors, one for each wheel, both capable of being controlled with the steering apparatus. Such a plan has been put into actual practice by several manufacturers of electrical vehicles, who gear their motors to the wheels, or use the hub to support either the armature or field magnets, as the case may be. One maker of American steam carriages has adopted a similar construction, connecting several small cylinders



FIG. 21.—Bergman's Steam Motor Wheel. A number of steam cylinders are arranged within the hollow hub of the wheel, so as to act on a common crank on the axle. The action is on the plan of a compound engine, the steam being exhausted at low pressure.

direct to each wheel hub. The plan has its advantages, but is by no means as simple, accessible and slighty as using one motor with sprocket connections to the centre of the rear driving shaft. (4) The driving wheels may be attached to the rotating axle by clutches, which may be "thrown out" by geared connections to the steering mechanism. To be really practical the act of disengaging must be effected by the steering lever, otherwise the driver might forget it at the very time it was needed most. The disadvantage of the arrangement is thus obvious; for, since a considerable motion of the lever is required to release the clutch, the device would be of use only on short curves, as in turning street corners, when the lever is put all the way about. On long curves

there could be no certainty that disengagement had been effected, unless complex devices and long connections were employed, greatly to the detriment of an easy operation of the steering lever. With the best arranged mechanism there must be some stress and strain on the drive wheels, in consequence of attempting by hand what should be accomplished automatically. Also, if the clutch is to be thrown out every time the steering wheels incline, ever so slightly, the driving must be irregular, and the speed consequently impaired. (5) The hub of each wheel may be provided with a ratchet arrangement, adapted to engage the axle and prevent it from rotating forward without engaging the wheel. Such a construction was used on foot-propelled tricycles twenty years ago, but was then found faulty because, in turning corners, the inner wheel had to do the driving. Since that time several improved designs have been made that allow of working in a reverse direction, the pawl being so hung as to shift by slight friction contact, so that, if the axle rotates forward, it will drive the wheel forward, and also the contrary. With all produced to date, however, the same fault has been found: When attempting a slight hill, there is no way of controlling the vehicle except by applying the brake until the power is reversed and the pawls can take a positive grip. Altogether, the best pawl and ratchet devices are uncertain and unsatisfactory in action and also seem unmechanical and unsuitable for motor vehicle use. (6) The construction most usually adopted is to attach both drive-wheels rigidly to a revolving axle bar, which is divided at the centre to connect with a system of *compensating* or *balance* gear wheels enclosed within a cylindrical case carrying the sprocket. Here there is no loss of power; no need of lowering the speed on curves of safe radius, and no necessity for complicated and troublesome devices for coupling the motive and steering functions.

The Requirements in Balance Gears.—The balance or compensating device, as used on motor vehicles, is commonly called a “differential gear,” from the fact that the primary object involved in its use is, as we have seen, to allow of differentiation or compensation in the speeds of the two geared wheels and their axles in making curves. Any device that will admit of a steady

drive in straightahead running, a difference of speed in the two drive-wheels in turning corners, and a rapid restoration of normal conditions, is usable for this purpose. There is, however, another necessary function, which may not be omitted—the differential must also be be a “balance gear.” That is to say, it must combine with the function of compensation an even or balanced transmission of power to both wheels. Each wheel, so long as it is in motion, must be driven with the same degree of power.

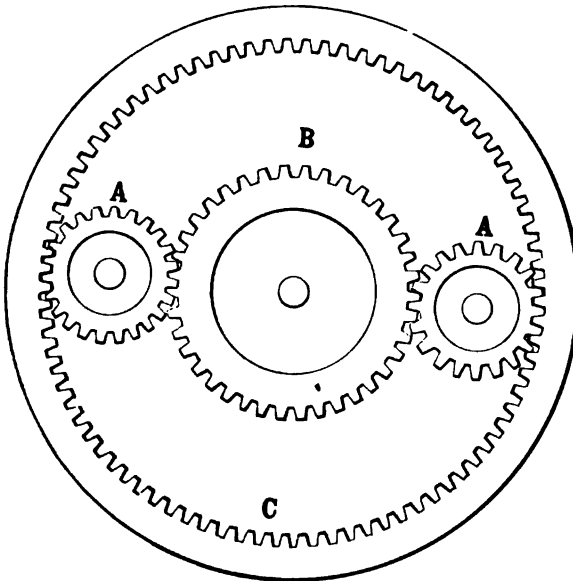

FIG 22.—A form of Differential Gear formerly used on Tricycles. The studs of the pinions, AA, are set in spokes of the sprocket, turning on their own axes only when either of the wheels of the vehicle, attached respectively to B and C, cease rotating, as in the act of turning.

At no time, even on short turns when one wheel is stationary, acting as a pivot, is it permissible that, say two-thirds of the power, be sent to one drive-gear, and one-third to the other. The power, transmitted from the centre of the divided axle shaft, must always be the same in both directions, even though one wheel be stationary. On some driven vehicles, particularly two-track foot-propelled tricycles, in which the steering wheel is set directly ahead of one of the drivers, so as to progress on the

same track, it is desirable to use a compensating gear that is not a balance gear, because more power is required on one side than on the other. The failure to understand this fact in the early days of cycling led to considerable uncertainty in the steering of tricycles. One of these early machines, a three-track tricycle—one having the steer wheel hung forward the centre of the two drivers—had the compensating device shown in an accompanying figure, instead of the true balance gearing it should have had. The device shown would have answered excellently well in a two-track tricycle, for the reasons noted above. As may be seen, the device consisted of a large internal gear wheel, within which and rotating about the same axis was a smaller external gear or spur wheel—the two meshing with the spur pinions at top and bottom, as shown. The large internal gear was secured to the axle of one wheel, the smaller or spur wheel to the opposite one, and power was applied through the pinions hung on the sprocket. The result was that the power-driven pinion transmitted more power to the internal gear, because of its greater diameter, than to the spur gear, thus giving one wheel a tendency to revolve more rapidly than the other.

Automobile Gears.—The most familiar form of balance gears for compensating the drive wheels of motor carriages is the bevel, or miter, gear train. This is the original form of the device, and was used on steam road wagons as early as 1843. As shown in the figure, the sprocket or spur drive wheel has secured to its inner rim several studs carrying bevel pinions, which, in turn, engage a bevel gear wheel on either side of the sprocket. These gear wheels, last mentioned, are rigidly attached on either side to the inner ends of the centre divided axle-bar, one serving to turn the left wheel, the other, the right. When, now, power is applied to the sprocket, causing the vehicle to move straight forward, it may be readily understood that the bevel pinions, secured to the sprocket, instead of rotating, which would mean to turn the drive wheels in opposite directions, remain motionless, acting simply as a kind of lock or clutch to secure uniform and continuous rotation of both wheels. So soon as a movement to turn the vehicle is made, causing the wheels to move with different speeds, a fact already mentioned in connection with horse-

drawn carriages, these pinions begin to rotate on their own axes, allowing the pivot wheel to slow up or remain stationary, as conditions may require, while still continuing to urge forward the other at the indicated speed. The principle involved in the device may be readily expressed under four heads: (1) When the resistance offered by the two drive wheels and attached gear is the same as when the carriage is driven forward, the pinions cannot rotate. (2) When the resistance is greater on the one wheel than on the other, they will rotate correspondingly, although still mov-

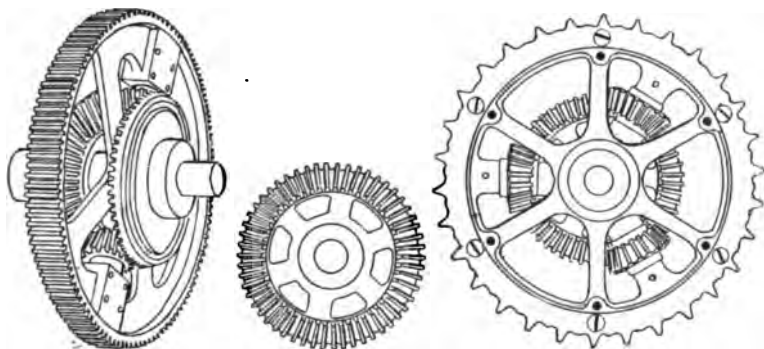

FIG. 23.

FIG. 24.

FIGS. 23 and 24.—Bevel Gear Differentials. The sprocket gear carries three bevel pinions set on studs on three of its radii. These pinions mesh with bevel wheels on either side, which wheels are attached at the two inner ends of the divided axle shaft. The spur drive has two pinions rotating on radii, and shows the action to better advantage.

ing forward with the wheel offering the lesser resistance. (3) The pinions may rotate independently on one gear wheel, while still acting as a clutch on the other, sufficient in power to carry it forward. (4) If a resistance be met of sufficient power to stop the rotation of both wheels and their axles, the condition would affect the entire mechanism, and the pinions would still remain stationary on their own axes, just as when in the act of transmitting an equal movement to both wheels.

For light carriage work the sprocket or spur drive generally carries two pinions, as shown in the figure, but in larger vehicles the number is increased to three, four, or six, and the size, pitch and number of the teeth varied, according to requirements. Of course, it is essential that the equalizing gears be properly

chosen for the work they are to perform, in the matter of the number of the pinions and of their teeth, as well as of the metal used, since the great strain brought to bear on them will inevitably cause wear and strain. With even the best made bevel-gears there is a danger of end thrust and a tendency to crowd the

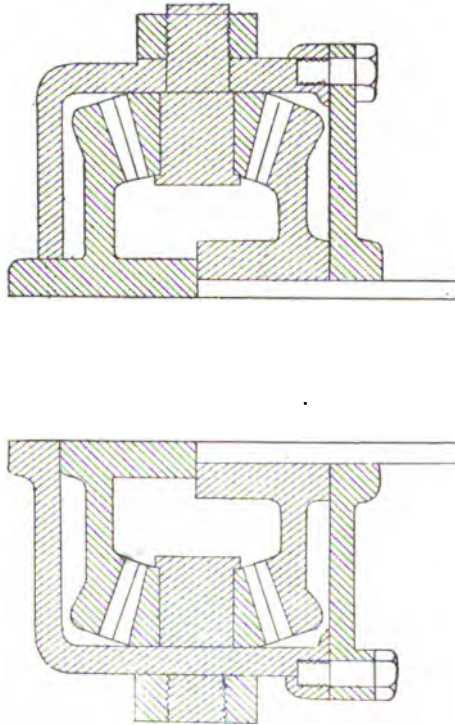

FIG. 25.—Section through the axis of a bevel gear differential train, showing two bevel pinions attached at top and bottom of the sprocket drum, and two bevel gear wheels one on the through axle shaft, the other on a rotating sleeve.

pinions against the collars, with consequently excessive wear on both. The result is a looseness that demands constant adjustment.

Spur Compensating Gears —In order to avoid the difficulties encountered with bevel gears, spur-gears were invented, and are now increasing in popularity. In this variety the theory of

compensation is the same as with bevel gearing; a divided axle, whose two inner ends carry gear wheels cut to mesh with pinions attached to the sprocket pulley. These pinions are, however, set in geared pairs, with their axes at right angles to the radius of the sprocket, which is to say parallel to its axis. As will be seen in the accompanying illustrations, the pinions of each pair are set alternately on the one side or the other of the sprocket, meshing with one another in about half of their length, the remainder of each being left free to mesh with the axle spurs on the one



FIG. 26.—One form of Spur Differential or Balance Gear. The two inner ends of the divided axle shaft carry spur wheels, which mesh each with one of every pair of the three pairs of open pinions shown. As these pinions mesh together both rotate on their axes as soon as turning of the wagon begins.

or other side. Both these models have three pairs of pinions, one of each meshing with either of the axle gears. With one the ends of the divided axle carry internal gears, with the other true spur-wheels. The operation is obvious. When the vehicle is turning, one rear wheel moves less rapidly, causing the pinion with which it is geared to revolve on its mate, which, in turn, revolves on its own axis, although still engaging the gear of the opposite and moving wheel of the vehicle. The motion is thus perfectly compensated, without the wear and thrust inevitable with bevels.

A Universal Joint Differential.—Another differential device, which has been used on some European vehicles, and was formerly patented in the United States, is shown in the accompanying figure. In this, as in other forms of differential gearing,

the axle shaft is divided at the centre, but instead of rigidly attached gears, carries a universal joint on each inner end, on which is a short shaft and a small spur pinion. Over the divided axle shaft are two hollow sleeves, which work freely over it, and are connected together by a gear box, as shown. Within this gear



FIG. 27.—Another form of Spur Balance Gear. The action is the same as in Fig. 26, except that the inner ends of the divided axle carry internal gear wheels, each of which meshes with one pinion of each pair.

box the two ends of the wheel axle shafts are arranged in bearings at an angle of about thirty degrees, so that the pinions can mesh. The driving is done by a sprocket attached to the outer hollow shaft just mentioned, and the motion is transmitted to the inner shafts attached to the vehicle wheels on either side by the differential gearing; the spur pinions, in this as in the former cases, locking fast without rotating so long as the motion of the wheels is equal and the carriage is driven straight ahead. As soon as a turn is made the pinions begin to rotate with the compensating effect found in the bevel and spur gear trains noticed above.

A rather simpler variation of this device has been proposed, although not widely used, which consists of two gears slightly beveled, one mounted direct on the straight axle shaft, the other,

on a universal joint, as shown. By this construction one universal joint is saved, while the compensating action of the device is not at all impaired.

Disadvantages of a Divided Axle Shaft.—The practice of dividing the axle shaft, thus disconnecting the two wheels of the vehicle, is a source of weakness which was recognized and provided against long since. Although, theoretically, the axle is divided at the centre, as we have described, the construction now usually adopted is to mount one wheel on the axle shaft and the other on a hollow shaft or sleeve which works over it. The

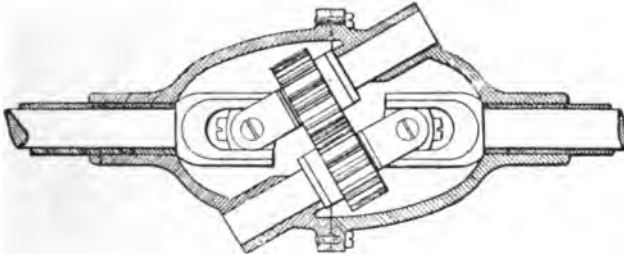

FIG. 28.—A Universal Joint Differential. The sprocket or spur drive turns the sleeve which holds the gear case here shown in section. So long as travel is straight ahead neither pinion rotates on its axis, but as soon as a turn is made rotation begins, thus allowing compensation of the motion of the two wheels of the wagon.

solid shaft can then be made as long as the width of the vehicle, the differential gear wheel belonging to it being secured about midway in its length. The other or hollow shaft is about half as long, so that its gear is attached at the end and is immediately opposite the other, both meshing with the pinions attached to the sprocket. Such a construction involves no other variation from the method of attaching the differential gear-train to the ends of the divided axle than making the eyes of the two gear wheels of different diameters, so as to fit the axle shaft, on the one side, and, the hollow axle, or sleeve, on the other. The sprocket is then inserted between them, being held in position by the meshing of the axle gears with the pinions, itself turning loose on the solid through shaft. The inner, solid axle shaft is secured in position by suitable collars. The arrangement may be understood by reference to Fig. 25.

Another Through Axle Shaft.—Another typical method for securing the strength and solidity of a through axle shaft is to attach both wheels to hollow axles of the same diameter, each of which carries on its opposite, or inner, end the gear wheel of the differential train. Another tube, called the "liner tube," of the same length as the width of the vehicle, is then inserted in the hollow axles, and the two are brought together so as to bear upon a collar secured to the centre of the liner tube. The sprocket and

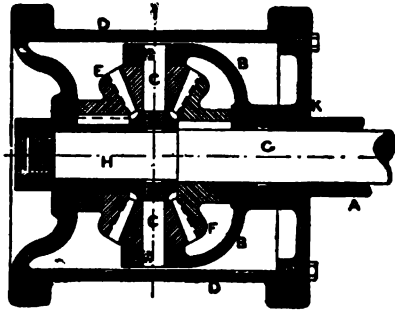

FIG. 29.—The Hub-Enclosed Differential of the Riker Carriages. A is the rotating sleeve carrying the drive spur. It is bolted to the yoke carrier, B, and the flange piece, K, as shown. C and C are the studs of the bevel pinions attached to the yoke carrier, B. F is the bevel gear wheel keyed to the rotating through axle shaft, G, whose opposite end is rigidly attached to the other hub. The bevel gear, E, is keyed to the in-flanged portion of the hub, D, turning on the reduced portion, H, of the rotating axle shaft.

differential pinion train are inserted and held in place in a fashion similar to that used in the previous device, the inter-meshing of the bevels serving to support it.

A Hub-Enclosed Differential.—The problem of how to secure compensation of motion between the two rear wheels, and at the same time overcome the disadvantages of the divided axle shaft is solved in a different fashion by the Riker Electric Vehicle Co. Their device is, briefly, to construct the wheels with box hubs and to enclose the differential gear-train in one of them. By this means the carriage frame enjoys the full advantage of a solid through axle shaft, and the divided connection is made at one end instead of at the centre. The mechanism is as follows: A solid through axle shaft is rigidly attached to the hub of one wheel, and has the opposite one running loosely upon it, secured

by nut and washer, as in the construction used for horse-drawn vehicles; howbeit, the gearing within the hub prevents its ready removal by unscrewing the nut. Over the solid through axle shaft, which rotates with the wheel attached to it, is sleeved a hollow rotating shaft, which carries the drive sprocket or spur. One end of this second shaft works on a bearing with the drive gear wheel, the other carries a hemispherical yoke-carrier to which are studded differential bevel pinions having their axes on the radii of the shaft. To the rear of this yoke piece is a circular

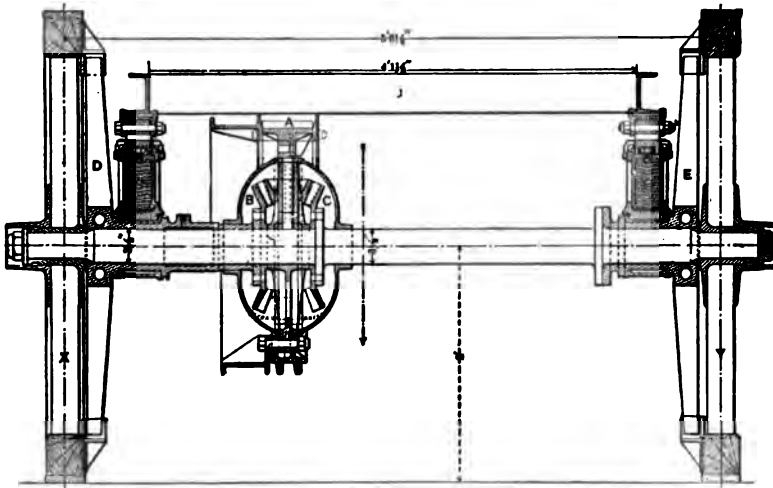

FIG. 30.—The rear axle of the Thornycroft steam wagon, showing the peculiar arrangement of the differential gears and driving connections. The driving is by the spur gear, A, attached on the gear box in the usual manner. The bevel gear, C, is mounted rigidly on the right side of the solid through-axle shaft. The gear, B, is similarly mounted on a sleeve at the left. The wheels, X and Y, turn loose on the through rotating axle, being driven by the springs, D and E, which bear upon lugs at the rim, as will be subsequently explained. This arrangement permits the removal of either wheel, as in horse carriages. G and F are the wagon springs, one resting above the rotating axle, the other above the rotating sleeve.

flange piece of a size to fit the inner circumference of the box hub, and turn loosely, when the differential gearing is brought into action: when the drive is straight ahead it turns with the hub, being of one piece with the yoke carrying the bevel pinions. The differential train is completed by the addition of the two side gear wheels, meshing with the bevel pinions, as in other systems of compensating mechanism. One of these gear wheels, the inner

one, is keyed to the solid through axle shaft, and turns or stops, according to the motions of the opposite wheel of the vehicle. The other is keyed to an in-flanged sleeve on the hub, this sleeve working loose on the extremity of the solid axle shaft, which is turned to a smaller diameter than the remainder of the length, and is terminated by a nut and washer, as previously mentioned.

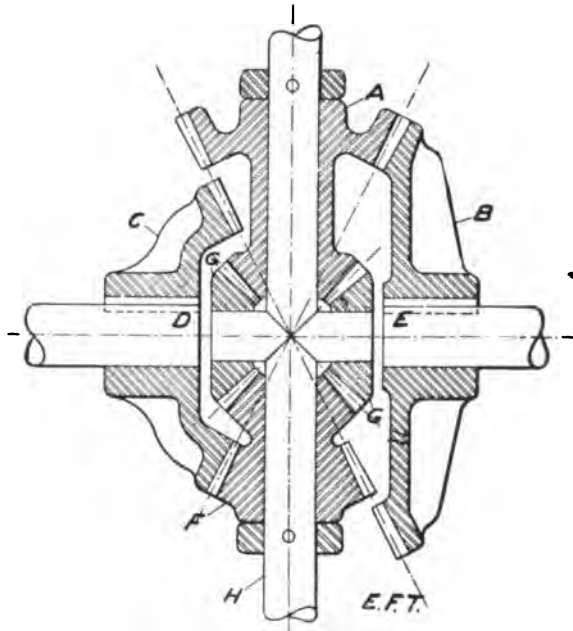

FIG. 30a.—Plan view of a type of differential and transmission gear for permitting the use of dished wheels. H is the driving shaft, which drives the bevels, B and C, on the two half axles, D and E, through the bevels, A and F. These last are loose on H, being held rigid by intermeshing with pinions, G, G, carried on a cross arm on H. Differential action between the two rear wheels is obtained when, in turning, B or C offers resistance to the rotation of A or F; such resistance causing the pinions, G and G, to rotate on their axes, compensating the movements of the two wheels, as in other differential gears. This device allows the use of dished wheels, since, as is evident, the gears, B and C, may be inclined at any desired angle together with their axles, by merely altering the angles of the bevels. The ratios of the gears, B and A, and C and F, being the same the balance of speed and power in transmission is maintained.

The differential action is obvious, since the bevel pinions are studded to a yoke-carrier at the end of the hollow drive-shaft, instead of to the sprocket or driving spur; one bevel-gear of the train being secured to the axle solid with the wheel opposite to the differential hub, and the other to the body of the differential hub itself.

CHAPTER THREE.

STEERING A MOTOR CARRIAGE.

Steering Gear of Automobiles.— In a horse-drawn vehicle, as we have seen, the front axle shaft is centre-pivoted below the body of the carriage and in turning bears on the “fifth wheel.” Such an arrangement is the most practical for this class of vehicle, since the tractive power, the horse, can pull in any direction without the use of further appliances than the guiding lines, or reins. In motor vehicles, however, it is not always practicable to so combine the steering and tractive functions, as to imitate the actions



FIG. 31.—Panhard-Levassor Light Two-Passenger Car, having a Swinging Front Axle. The steer wheel pillar carries an arm on its end to which is attached a link bar working a similar arm on the pivot of the axle, as shown.

of a horse. Consequently, it is necessary to provide mechanical means for shifting the direction of the forward or steering wheels. This result may be accomplished by attaching some kind of lever, sprocket, or spur-gear arrangement to a “fifth wheel,” and operate it by a handle near the seat of the carriage. To successfully accomplish this result with a steering handle, such as is used on most American motor carriages, would require a considerable expenditure of muscular energy and a wide angle of leverage, besides involving delay and difficulty on many turns. With a well-gearred steering wheel it has been successfully adopted by Panhard and Levassor, in one of their light two-seated cars. For general purposes, however, the simplest and readiest construction

for attaining easy steering, and at the same time securing the needed stability of the frame, is found in the use of a rigid through axle shaft and knuckle-jointed stud axles.

Pivoted Stud Axles.—In automobiles the forward axle shaft is attached beneath the body of the vehicle, so as to admit of no rotary movement whatever on its own centre. At each end it



FIG. 22.—The Oakman-Hertel Gasoline Carriage, showing the steer wheels set in and turned by bicycle forks.

carries a fork, or yoke, to which is pivot-bolted, at right angles to the axle shaft, so as to form a true knuckle-joint, a boss carrying two branches, one of them of cylindrical shape to fit the axle box of the wheel, which is suitably secured, as in horse-drawn vehicles, so as to rotate freely; the other being an arm, shaped for attaching the transverse steering link bar. This link bar is generally arranged to connect the steering arms of both stud axles on the through axle shaft, the connections for the control handle or wheel, placed conveniently to the driver's hand, varying with different manufacturers. Pivoted axles, which are generally known as the Ackerman axles, and were invented by a certain Lankensperger of Munich, as early as 1819, thus furnish the readiest and simplest means for steering motor vehicles, at the same time permitting maintenance of stability. The transverse

steering link bar attached to an arm at either end is readily manipulated by the driver, and with but small exertion, since the pivots, attached direct to the axles of the wheels, permit a wide angle of variation in the vehicle's direction of travel for a very slight shifting of the steering handle. The balance of leverage being also in the driver's favor, it is possible to turn the vehicle in any desired direction quickly and with ease. This same fact also involves that the steering handle cannot be wobbled or vibrated.

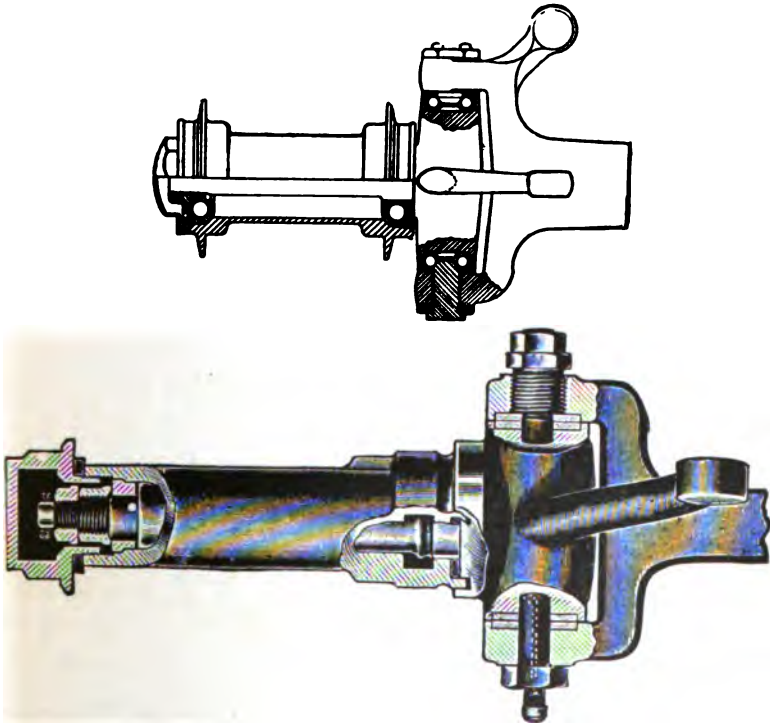

FIGS. 33 and 34.—Two forms of Stud Steering Axle, showing differing arrangement of steering arms and pivots.

The Theory of Steering Axles. — The operation of pivoted steering axles depends upon fixing the pivot as near as possible to the centre of the wheel, in order to enable the greatest arc of operation for the smallest motion of the hand lever. In this respect the steering wheel of a bicycle is typical, and some makers

of automobiles who use steering wheels similarly mounted on forks, either in pairs, as in the Oakman gasoline carriage, or as a single front wheel, as in the Knox three-wheel gasoline carriage, are able thus to secure a remarkably easy and efficient leverage. But, since this construction is not the most suitable for heavy carriages, and is not generally popular, manufacturers and

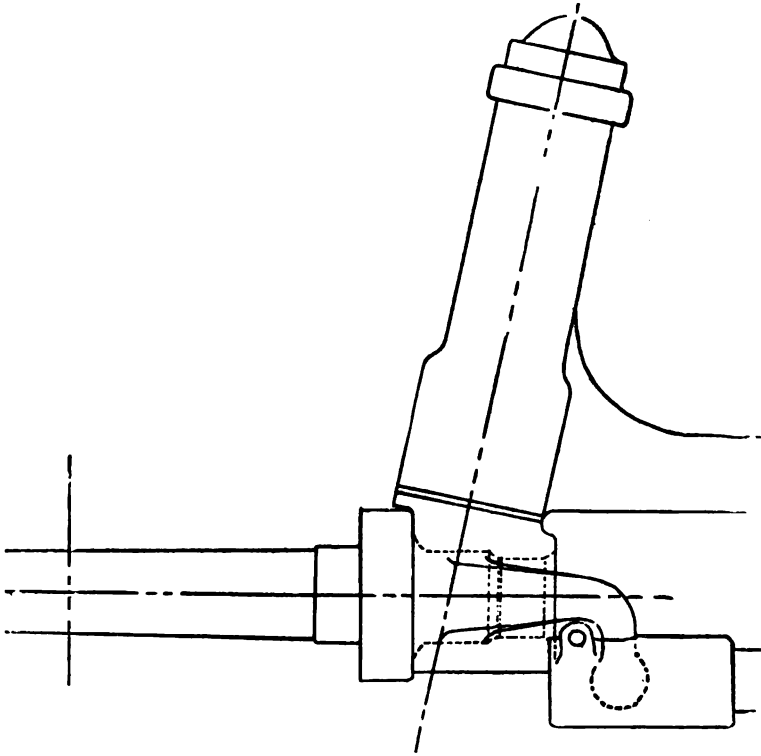

FIG. 33.—Inwardly Inclined Steering Pivot of the Duryea Carriages. The lines passing through the pivot and across the axle converge at the point of contact of the tire with the ground, thus securing the effect of centre steering.

inventors have busied themselves devising other methods for accomplishing the same result. One of these is to incline the stud axle downward at such an angle as will cause the tire, or periphery, of the wheel to strike the ground at a point coincident with a line drawn through the knuckle pivot. As an additional ad-

vantage for this construction, it is claimed that the force of a collision is delivered at or about this line of incidence, rather than on the hub or its axle connection, thus ensuring greater security, and saving the driver a shock. Another device is to incline the pivot axis inward, leaving the axle horizontal, or nearly so, with the result that, as in the previous case, a line drawn through the pivot strikes the ground at the same point with the periphery of the wheel which is itself in a vertical position.

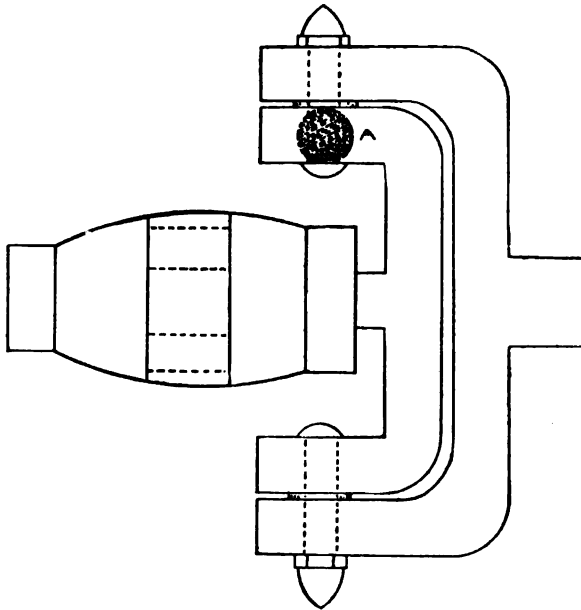

FIG. 36.—The Haynes-Apperson Double Yoke Steering Pivot Axle. The steering arm is attached at A, thus securing the turning effect at approximately the centre of the wheel hub.

Constructional Points on Steering Axles.—It is of prime importance that the construction of the steering knuckles of pivoted axles should be as heavy and durable as the size and weight of the carriage will permit. To neglect this point and attempt a lighter and prettier-looking joint will involve rapid wear and loose bearings to the detriment of good steering quali-

ties. At this point it may be in place to remark that it seems to be a regular superstition with some manufacturers of motor carriages that lightness of construction is the first thing needful in a successful vehicle. For this reason many of them weaken their carriages by using tubular frames with an excessive number of joints, thus making nearly inevitable a rupture somewhere under stress of vibration or constant use on rough roads. One make of American gasoline carriage, which combines a number of exceptionally excellent mechanical conceptions, carries the idea of lightness to such an extreme as to make the various parts far too small to be really serviceable under test conditions. It is probable that the total weight thus saved would not equal one-

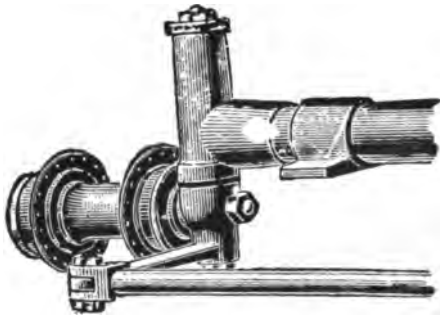

FIG. 37.—Form of Steering Head used on the English Daimler Cars and Others. The steering arm projects from the front of the pivot. Part of the drag link is shown attached.

third of a hundred pounds, a matter of no particular moment, when we consider that, as it is claimed, the motor is of ten horsepower capacity. Contrary to this practice, the worth of a motor carriage, with any type of motor, may be fairly estimated by considering how substantial and durable are the parts exposed to running stress—such are the brake drums, the differential gearing and the steering mechanism—and, whether such parts are of sufficient proportions to admit of easy operation and the resistance of ordinary violence. These qualities are particularly essential in the construction of the pivoted axles, and may be readily recognized in the accompanying figures of typical structures.

Other Steering Pivots.—The ends of superior strength and centre-steering are approximated differently by other carriage

builders. The Haynes-Apperson Co. uses a double yoke arrangement; one yoke being of a piece with the through axle shaft, the other pivot-bolted at each extremity with the first, and carrying the axle spindle at its centre. The National Automobile and Electric Co. have a vertical bearing at the end of the axle shaft, instead of the usual fork, and within this works a short stud

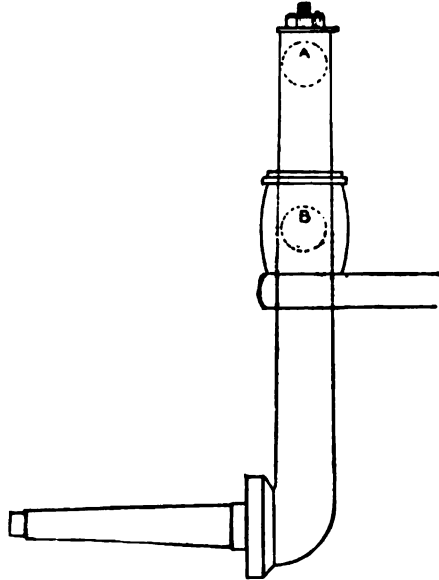

FIG. 33.—Form of Steering Pivot and Axle used by the National Automobile and Electric Co. The steering arm is attached at the point marked A.

piece carrying the horizontal spindle at the base, the steering arm being bolted at the top. This device seems to be a simplified variation of the one used on the Panhard vehicles, which have a similar upright bearing, or cone pivot, carrying an axle stud and axle in similar fashion, but with the steering gear attached at the base.

Pivoted Wheel Hubs.—Several manufacturers, most notably the Riker Electric Vehicle Co., have attempted to improve the operation of the pivoted steering wheels by enclosing the pivot and lever arm attachments within a hollow hub. The construction includes a hollow cylinder or tube length, which is pene-

trated by the end of the axle shaft and pivot-bolted to it, so as to turn in either direction under impulse from a steering handle fixed to its inner end and running parallel with the main axle shaft. Around the edges of this pivoted tube run two hard steel cones which engage a train of ball-bearings enclosed in a circular ball-race or retainer fixed on the inside circumference of another and larger tube or box, which forms the hub of the wheel, and runs freely upon the first, the pivoted box, on the train of ball-bearings. This device bringing the pivot exactly at the centre of the wheel is an eminently effective means of accomplishing

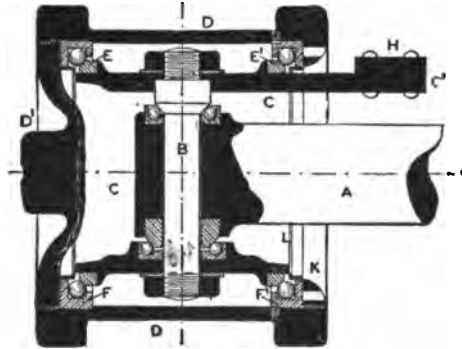

FIG. 32.—Pivoted Steering Hub used on the Riker Carriages. A is the axle shaft; B, the pivot connecting A to the tubular swinging hub, C. E and E' are circular cones which bear on the balls mounted in the ball races, F and F', thus permitting the hub D to rotate independently on the inner tube, C. The steering arm, H, attached to C turns both C and D on the pivot, B.

easy and perfect steering. The construction must, however, be strong and comparatively heavy, so as not to achieve ease of operation by a sacrifice of durability.

Numerous inventors have adopted the general idea of placing the pivot within the hub, and effecting the steering by lever and swivel attachments, but the Riker hub is typical of most such devices. The Clubbe and Southey pivoted hub operates on a simpler plan. The fork, or yoke, on the through axle shaft is slightly bent forward at the end, so that a pivot bolt through the eyes pierces a boss attached tangent-wise to a short tubular axle bearing, in which the stud axle, carrying the wheel, revolves freely. The hub is hollow and hemispherical, so as to contain the whole mechanism of the pivot joint, which is slightly forward of

the centre, giving a caster action to the wheel in turning. The steering arm is attached to the axle bearing about midway in its length and opposite to the pivot boss.

Requirements in Steering Motor Carriages.—While the novice in mechanics may consider that some of the details and contrivances, thus far described, are quite unnecessary, he will readily recognize their importance when the facts are explained. Thus, when informed that the steering wheels of an automobile must, in turning the vehicle, describe concentric arcs, on radii which differ in length by the distance between the wheels, he will understand that the axle of each must project from the perch at an angle diverse from that made by the other. The arcs thus described must be concentric in order to maintain both wheels in

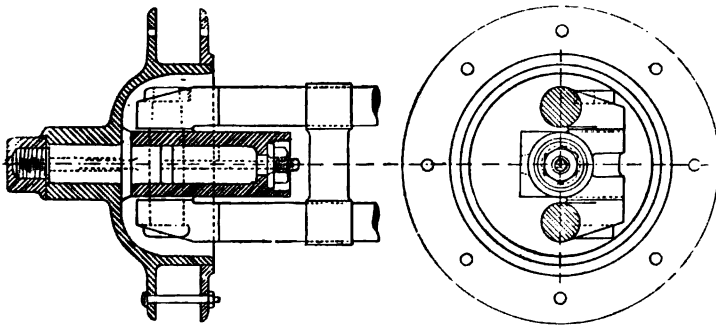

FIG 40.—The Cluibe and Southey Pivoted Steering Hub used on the Carriages of the Electric Motive Power Co., of England. As may be seen, the pivot is to one side of the axle, thus giving the wheel a true caster movement in turning.

the same direction, without side-slip or resistance; they must be on radii of differing length, because, as is obvious, two parallel wheels, separated by even a minute distance, cannot run in the same tire track. The wheel axles must project from the transverse axle-tree at different angles, because the two wheels, having the same diameter, no matter how their relative speeds may differ, will by any other arrangement fail to run in the same curved direction. This principle is not applied in the steering of horse-drawn carriages for several reasons: (1) The wheels, being carried at either end of a centre-pivoted swinging axle-tree, are always held on the radius of the turning arc. (2) The steel tires

permit considerable slipping, impossible with rubber, thus allowing a moderately complete compensation of diverse arcs and speeds. (3) The motive power being derived from an outside agent—the horse—the continuous movement is not impaired, or the steering rendered uncertain, as must be the case in a self-propelling vehicle, which is moved from the rear. (4) As the careful driver very soon learns, the arc of turning must be on a radius of generally twice the carriage length, if an upset is to be avoided, although this depends on the speed and location of the centre of gravity.

The same principle is applied in railroad cars and locomotives in a manner impracticable for either horse or motor carriages. Here, although the wheels are always rigidly attached in pairs at either extremity of rotating through axles, and in fours to the

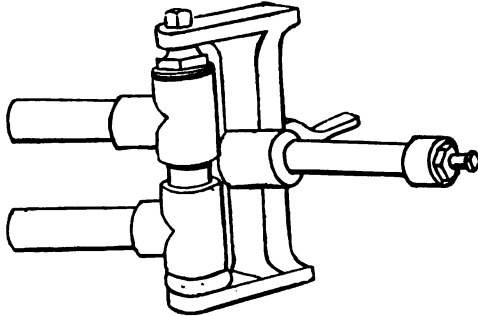

FIG. 41.—The Loomis Steering Head. This device differs from the conventional yoke and pivot arrangement in the fact that the yoke is on the stud axle instead of the axle-tree end, and is offset from the end centre, thus allowing of a castor movement.

trucks, composed of two parallel through rotating axles with their attached wheels, the differing concentric arcs described by the two rails of the track in rounding a curve are followed.

Constructional Theory of Railroad Wheels.—As may be readily understood, the theoretical requirements to enable the wheels on the axles of a railroad car to perfectly follow both rails of a curved track involves that they be constructed to form a cone, whose apex is at the centre of the described arc and whose base is the outside face of the outer wheel. In other words, the wheel nearest the centre of the curve would have to be made of smaller diameter than the other, which, although the theoreti-

cally perfect construction for curves, would render the car useless for straight-ahead travel, if practically carried out. To accomplish the desired end, however, car wheels have been made with a cone-shaped tread—forming, in fact, a double cone—the base of the cone being against the flange of the wheel. In turning a curve, then, the outer wheel, impelled by centrifugal force, rotates

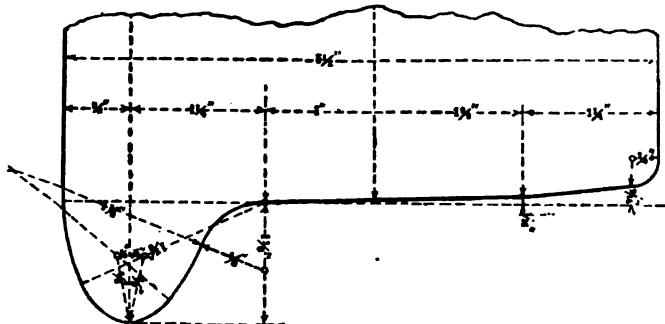

FIG. 42.—The Coned Tread of a Railroad Car Wheel, intended to allow the two wheels to describe concentric arcs in turning curves.

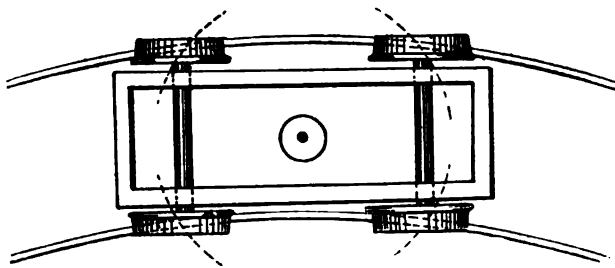

FIG. 43.—Position of the Wheels of a Railroad Car on the Rails in Turning a Curve.

on its largest diameter, while the inner wheel, from the same cause, rotates on its smallest. Thus is approximated the requirement that the two wheels on an axle should run on different diameters in making a curve. In practice the stress and friction of travel eventually wears down the coned surface, particularly at the flange of both wheels, where it is most needed, leaving considerable of the compensating effect on curves to the slipping of the wheels on the rails, or to the angular difference due to elevating the longer, or outer, rail of the track.

Angles of the Steering Axles.—With an understanding of the positive necessity of providing some means to keep both the steering axles of a motor carriage on radii from a common centre, in order to neutralize the tendency to side slip and skidding, and secure positive control of the vehicle's direction, it is evident that some arrangement must be included for varying the angles of

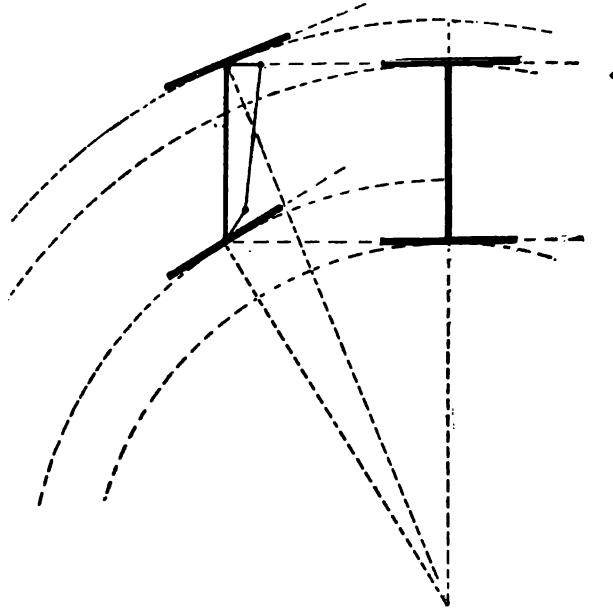

FIG. 44.—Diagram Illustrating the Position of the Steering Wheels in Turning. As will be seen, they both are tangential to arcs described on a common centre, as is necessary in order to describe such concentric arcs and give positive steering, when the motive impulse is from behind.

the two from the transverse axle bar. As may be readily understood, when a carriage's travel is changed from the straight-ahead direction to a curve, the steering wheel moving on the in-track, or smaller arc, must assume a greater angle at the axle than the outer wheel, which moves on the larger of the two concentric arcs. It is further evident that such variation of axial angles must be accomplished by some device at the steering arms of the stud axles. If these steering arms be fixed at right angles to the axles, so that the transverse drag-

link is of a length about identical with the distance between the wheel bases, any effort to turn the wheels in steering will shift the angles of both arms with the fixed axle-tree equally, hence, causing the axles to assume positions as radii from different centres. The result will be that the outer wheel will describe an arc tending to cross those described by all the other wheels, and may slide or rub, without revolving, as much as one foot in every

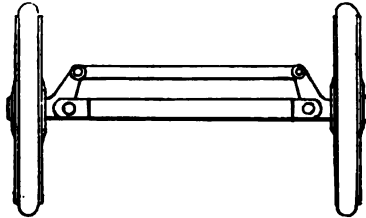

FIG. 45.

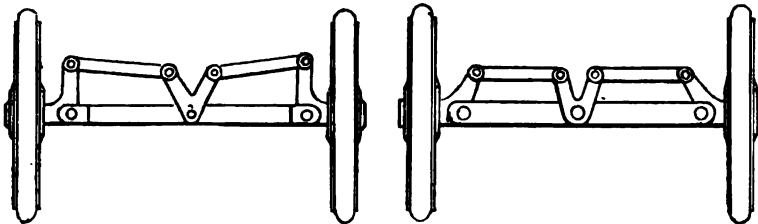

FIG. 46.

FIG. 47.

FIGS. 45, 46 and 47.—Diagrams of Motor Carriage Forward Axles, showing three arrangements of link bars and steering arms. In the first the steering arms are inclined inward at the required angle and connected across the carriage width by a single link. In the second the steering arms are fixed at right angles to the axle-tree, and the angle of inclination is made at a centre pivoted bell crank. In the third the angle of inclination is divided between the steering arms and the central bell crank. Theoretically, the sum of the angles in the third figure is equal to that in the first, and to the angle of the bell crank in the second.

six. Such a procedure must, of course, retard the progress of the vehicle very seriously, and, from the uncertainty of steering involved, must be particularly troublesome, even dangerous, on narrow turns. It is evident in this case that the outer wheel axle is at too great an angle, or that the inner is at too small an angle. The simplest method of at once obviating this trouble and also securing the proper angles of the axles is to incline the two steering arms inward from the right angle and make the transverse drag-link shorter than the distance between the axle

pivots. If the drag-link be forward the axle-tree, the steering arms are inclined outward.

With this arrangement, as may be readily understood, any effort to change the direction of the travel will cause the arm of the outer wheel to approach the right angle with the transverse through axle bar, and cause the arm of the inner wheel to move proportionately away from the right angle. Moreover, since the end of the transverse drag-link attached to this inner axle-arm must, in the act of thus widening the angle, be approached nearer and nearer to the immovable through axle bar, it must describe

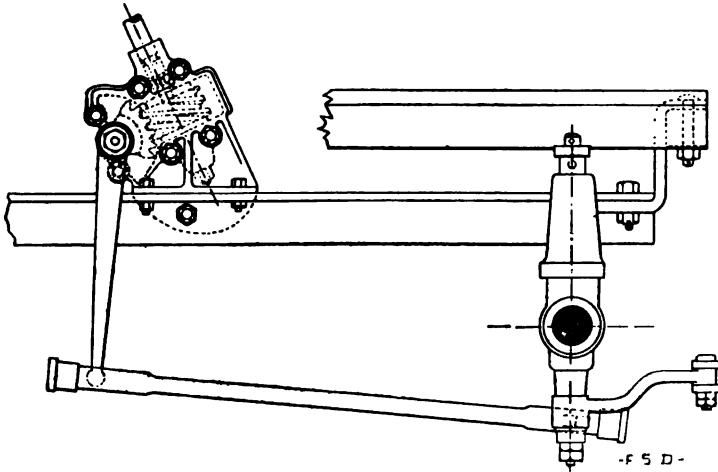

FIG. 48.—Steering Connections of the Panhard Carriages. The spindle of the steering hand wheel carries a worm gear at its base, which actuates a toothed sector, as shown. This swings an arm and moves the drag-link attached to the arm at the base of the steering head. The transverse drag-link connecting the two steering heads is attached to the arm extending from the front of the carriage. The link between the steering head and the sector arm has ball joints and can adjust the distance as the carriage rises and falls on the springs.

an arc, thus passing through a greater number of degrees than will the opposite, or outer, end. Consequently, the object of securing a greater angular inclination for the axle of the inner wheel will be accomplished and the proper difference for all usual conditions between the angles of the two, approximated. That is, although it generally happens that the angular inclination of the steering arms works best on curves of radius midway between the extremely long and extremely short, it has been found that

the difference is not sufficiently great to disturb the parallelism of the described arcs or cause damaging slips and skidding.

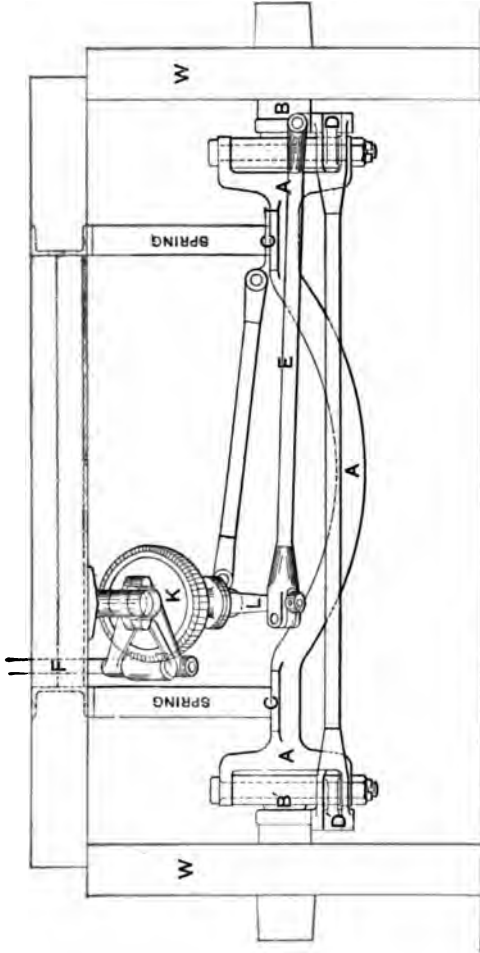

Fig. 49.—Steering Arrangements of the Thornycroft Steam Wagon. The hand wheel pillar, F, carries a worm pinion which meshes with the worm gear, K. This moves the arm, L, and actuates the link, E, whose motion is, in turn, transmitted to the transverse link between the arms, D and D', and the pivoted axles, B, B, of the wheels, W, W.

Arrangement of the Steering Handle.—The steering arms on the pivoted axle bosses are connected across the width of the carriage by a drag-link bar, which transmits the impulses given at the wheel or lever by the driver's hand. Most often the attachment is made by a second link bar, attached at one end to one of the steering arms, and, at the other, to the steering wheel or lever, so that this particular arm is dragged or pushed, according to the desired direction in steering. The majority of American motor carriages are equipped with a handle and lever—sometimes in the centre of the vehicle, sometimes at the side—while, in Europe, the hand wheel is the most typical arrangement. The accompanying diagrams show several typical methods of arranging the steering mechanism with reference to the steering link. One of the most common devices is that used in vehicles of the De Dion voiturette type, described as the "ordinary bicycle steering." The handle bar and post may be vertical or inclined, and is connected with the steering device in front by link rods, gears or chains. On some of the Panhard vehicles the link bar actuating the steering arm is jointed to a toothed sector which engages a worm thread on the end of the rearwardly-inclined shaft of the hand wheel before the driver's seat.

As regards lever steering and wheel steering it is mostly a matter of design. The first objection to the lever that occurs to the mind of a novice is that, if attached to a vertical steering head and of sufficient length to be convenient to the driver's hand, a larger arc will be described than is perfectly comfortable.

On this account, however, most lever steerings, operate not directly on the steering head, but through intermediate levers by which the power may be varied to suit the requirements of each turn. Generally speaking, a short steering lever turned at a considerable angle to produce the required deflection of the steering gear is preferable, although, in reality, it becomes a reduced and modified form of steering wheel. By lessening the load on the front of the carriage, by properly inclining the steering heads, and by providing to avoid all lost motion, the steering effort may be so reduced as to make possible the use of a short lever, such as is used on the Duryea and De Dion vehicles, with the accompanying advantages of easy, ready handling and small arcs.

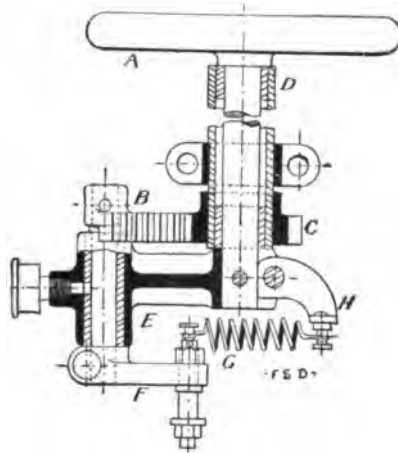

FIG. 50.

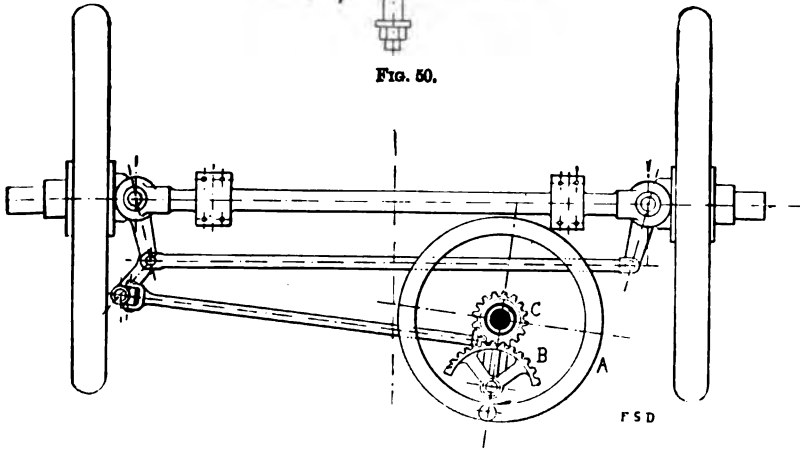

FIG. 51.

FIGS. 50 and 51.—The Steering Arrangement of the Gobron-Brillie Carriages. In both figures A is a hand wheel, at the end of whose spindle, D, is an arm, E, to which is pivoted a toothed sector, B. The arm, E, being moved as the wheel, A, is turned, carries around with it the pivot of the sector, B. This sector meshes with the pinion, C, turning loose on the steering pillar, as shown, and is accordingly rotated through an arc. Thus the arm, F, attached to the pivot of B, on E, has a double motion, which involves that the slightest movement of the wheel, A, is unusually effective in actuating the steering arms, through the link attached, as indicated, to the end of F. Also, any stress at the wheels is unable to reverse or disturb the movement thus directed. The spring, G, attached to the arm, H, serves to steady the movement and restore F to normal position when required.

Practical Points on Steering Angles.—In general, the steering angle of an automobile carriage, which is to say the sum of the inclinations of the two steering arms from the right angle, is between fifty and sixty degrees, giving an inclination for each arm of between twenty-five and thirty degrees. Some of the best makes of carriage have it at or about twenty-five degrees. As shown in the accompanying diagrams, however, various designers have modified the typical arrangement of inclining the steering arms inward and using a short drag-link to connect them. Some have adopted the device of placing the arms at right angles and using a link in two sections connected to a fork or

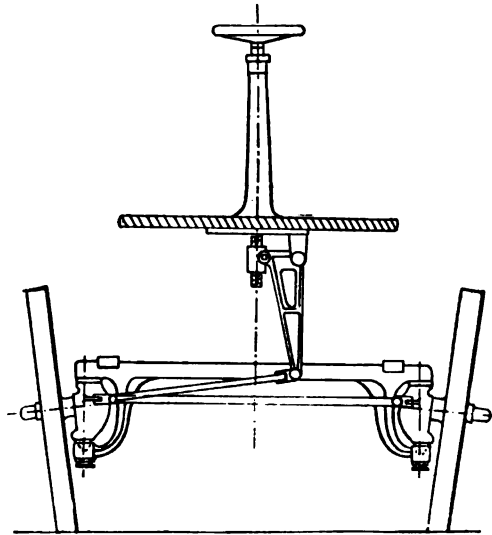

FIG. 52.—Steering Arrangement of the Clarkson-Capel Steam Wagon. The spindle of the steering wheel carries a screw at its end, which works a boss, as the wheel is turned, thus actuating the lever and drag-link attached to the arm of one of the axle pivots.

bell crank having the total required angle, fifty or sixty degrees, and pivoted at the centre of the fixed axle bar. Others have so combined this with the first-named construction as to divide the angle between the centre-pivoted bell crank and the steering arms, making the former, say thirty degrees and the two latter fifteen degrees each. The primary object achieved in either of these devices, as compared with those previously named, is to

ensure the end of ready manipulation of the steering lever. The first-named construction is the one best suited to carriages having the steering pivot in the theoretically correct place—within the hub. When for structural reasons the transverse drag-link bar is placed in front of the axle-tree, a position preferred by several manufacturers, the steering arms attached to the bosses of the swinging axles are inclined outward, instead of inward, at the angles found most suitable with reference to the width of the vehicle between the wheel pivots and to the diameter of the wheels. A very useful construction, used on the Duryea carriages and others, is to incline the upper end of the axle boss, or pivot, inward toward the centre of the vehicle, so that a line drawn through the axis touches the ground at the centre of the pneumatic tire. This achieves not only the desirable end of centre-steering, as already mentioned above, but also allows a certain inclination, or rake to the steering wheels, as in a bicycle, when making a turn. The rake is a positive advantage to ready steering qualities, when the inclination of the axle pivot is not at so great an angle as to bring unusual side strain on the wheels. Other things being equally favorable, it is also efficient in reducing the steering effort.

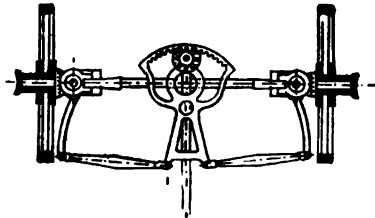

FIG. 53.—Steering Arrangement of the Amadée Bolee Steam Coach (1881). A hand wheel spindle carries a spur pinion at its base, which working on an internal geared sector, as shown, operates the bell crank, actuating the two transverse drag-links.

CHAPTER FOUR.

VARIOUS DEVICES FOR COMBINING THE STEERING AND DRIVING FUNCTIONS.

Front Driving and Steering.—It will require very little reflection to understand that to drive direct on a pivoted steering wheel must involve a peculiar and carefully adjusted gearing, so that the two functions, driving and steering, may be exercised without interference. Were it possible always to apply the power to the forward wheels it would be advantageous in a number of particulars. Since, however, its accomplishment demands the use of crown or bevel gears, with a consequent strength and weight of construction, it is not perfectly practicable in the lighter patterns of motor carriages. The accompanying figure of a combined driving and steering device, as used in some of the Hurlt electric cabs, shows one arrangement of gearing for accomplishing the result. Here *I* is the armature of the motor, *NN*, the magnets and *B*, a frame supporting the armature spindle which rotates on the axis, *XX*. To this spindle is attached the spur pinion, *P*, which meshes with the pinion, *r*, turning on the axis, *yy*, within the boss of the steering pivot. The spur pinion, *r*, is made in one piece with the bevel pinion, *a*, and this latter engages the toothed bevel ring, *b*, which is clamped to the spokes of the wheel, *RR*. As may be understood, it is possible to swing the wheel, *RR*, on the axis, *yy*, fixed in the yoke, *E*, without interfering with the transmission of driving power from the pinion, *a*, to the bevel ring, *b*, thus permitting the vehicle to be steered and driven on the same wheel.

A more recently patented device of the same description for electric wagons uses a separate axle for each steering driver, on which is mounted a separate motor. The power is transmitted by a spur pinion engaging an internally-gear ring secured to the spokes of the wheel, and the whole device, axle, motor and wheel, being pivoted to the end of a rigid transverse bar, may be turned by the steering gear. The steering pivots are operated by

a worm gear at the top of each being engaged by a worm pinion at the extremity of a transverse rotatable bar. In either of these devices the act of steering may be accomplished without moving the motor armature.

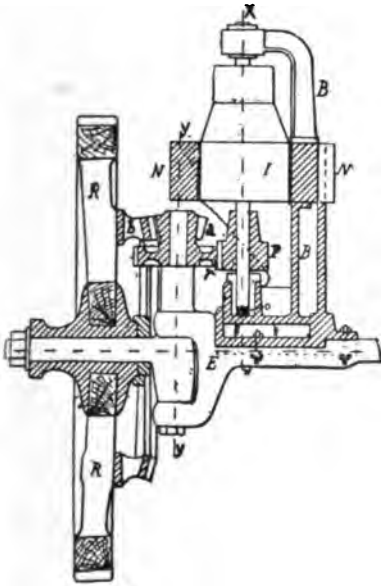

FIG. 54.

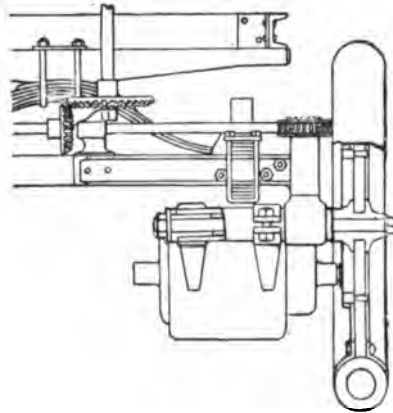

FIG. 55.

FIG. 54.—Motor Steering Wheel of the Hurtu Cabs. A drag-link attached to the arm of the pivots can turn the wheels without disturbing the operation of the motor.
 FIG. 55.—Steering Motor Wheel Arrangement, by which a worm gear and pinion device, actuated as shown by bevel gears, turns the stud axle entirely around with the attached motor and gearing, without interrupting a steady drive.

All-Wheel Driving.—Numerous devices have been introduced for the purpose of driving on all four wheels of a motor carriage. Most such are objectionable, however, on the ground of greatly complicating the mechanism and thus proving nearly impracticable for lighter kinds of vehicles. The accompanying figure shows one of the best of these, the subject of a recently granted patent. As may be seen, the driving is by two shafts and two sleeves running in the length of the carriage, and transmitting the rotative movement from two separate trains of bevel gears to the front and rear wheels by sets of universal joints. The front wheels rotate in pivoted bearings, so as to be effectually turned

in steering, without interfering with their motion on their own axes, or in any way altering the action of the motor. As may be readily understood, a proper arrangement of bevel gearing at the pinions attached to the rotating shafts and sleeves will give the effect of compensating the speeds of the two rear wheels in turning, according to the principles previously explained.

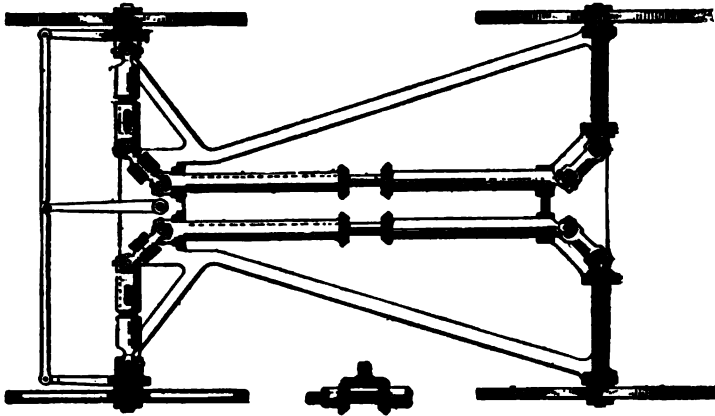

FIG. 56.—Recently Patented Device for Driving on all Four Wheels by a System of Universal joints. The steering arms are not inclined, since the wheels being driven follow their paths without slipping.

All-Wheel Driving and Steering.—The advantages to be gained in a practical device for applying power to all the wheels are still further enhanced by the additional feature of steering with all four. This is desirable, if we wish such advantages as come by driving on the front wheels and steering with the rear. To steer with the rear wheels only is not always practicable. When the front wheels only are driving it is impossible to propel the carriage up a steep hill, owing to the shifting centre of gravity. With the Cotta steam carriage the power is divided by a quadruple compensating gear into four equal and independent parts, and is then transmitted to each of the four wheels, which are 30 inches diameter with $2\frac{1}{2}$ -inch tires. By this arrangement the wheels, each being independent of the others, are allowed freedom in speed in passing over obstructions or unevenness in the roadway without reference to the travel of

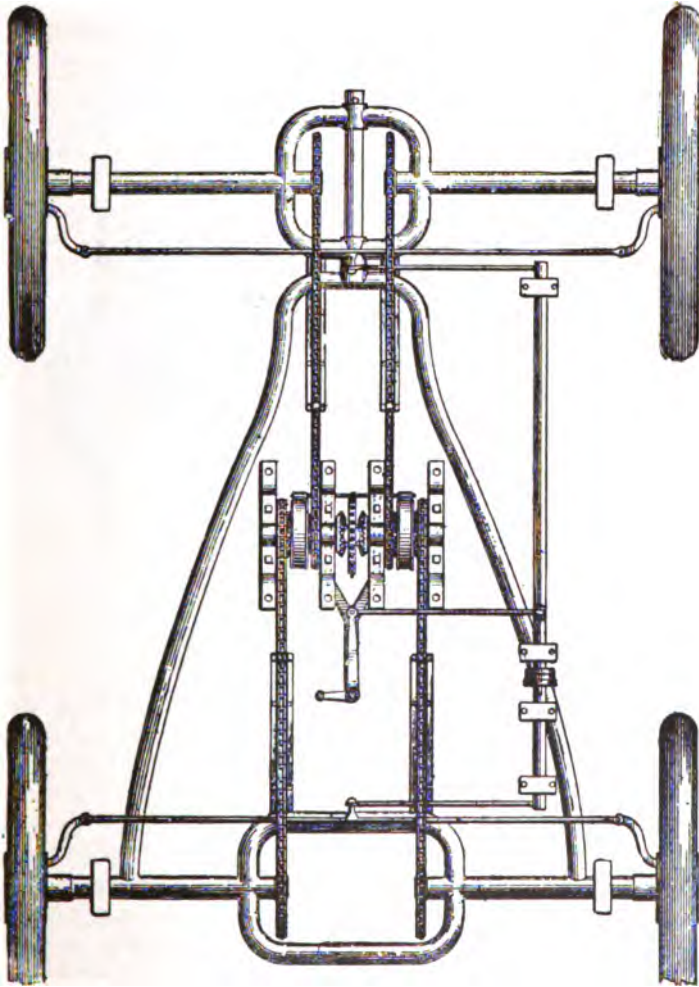

FIG. 57.—Cotta Carriage Frame for Four-wheel Driving and Steering. The motor drives on a balance gear at the centre of the frame, whence motion is transmitted to all wheels by chain and sprocket connections. All four hubs are pivoted for steering, and are connected in pairs across the width of the frame by drag-links. The two links are geared together, as shown, so that the travel of all the wheels may be varied at once by the steering lever.

any of the others, and under all conditions each wheel receives one-fourth of the power, and does its share of the propelling of the vehicle. It is plain to see the necessity of such a compensating device, when we consider that, on a perfectly smooth roadway and traveling straight ahead, each wheel would make a different number of revolutions in a given distance, owing to the fact that it is impossible to have tires inflated exactly alike, and



FIG. 58.—The Pretot Fore-Carriage shown attached to a Victoria Carriage. The attachment is on a fifth wheel running on roller bearings, and turning by geared connections with the steering hand wheel.

also that some wheels will carry more weight than others, depressing some tires more than others and giving them a diminished radius and less circumference.

“The Cotta steering pivot is in the direct centre of the wheels, the wheels only oscillating in turning a curve, doing away with all side jar on the steering lever on rough roads, so objectionable in other vehicles. As this vehicle is intended to be a success on bad roads as well as good ones, the makers have arranged to guide all four wheels, bringing the rear wheels around in the same track as the front ones in rounding a curve, and making but two tracks, instead of four, when in the mud, making it as easy to travel on a curve as straight ahead.”

As to Rear Steering.— In considering some of the advantages to be derived from front driving arrangements, the idea of steering with the rear wheels only might seem equally advantageous to some minds. But this is impracticable for motor carriages, since its adoption would mean the destruction of good steering

qualities. The situation is well expressed in the "Horseless Age": "The objections to rear steering are that, when a carriage is standing near a curb, it is impossible to turn off sharply, as the steering wheel (rear) would run into the curb; and that, when near a ditch or impassable section of the road, in order to turn away from these, the steering wheels (rear) must first run toward them, which may lead to difficulties."

Automobile Fore-Carriages and Motor Wheels.— Among other solutions of the important problem, as some consider it, of combined driving and steering on the front wheels, may be mentioned such devices as the Pretot fore-carriage, manufactured in France and England, and also introduced in the United States. As shown by the accompanying figure, this device is a two-wheeled truck, which may be attached to almost any vehicle by slight alteration, and capable of being turned for steering on a kind of fifth wheel arrangement running on rollers. The fore-carriage itself contains a gasoline motor of between five and ten horse-power, with suitable transmission gear, permitting three speeds forward and a reverse, and is controlled by the single lever to the rear of the steering wheel. Fuel for the motor is carried in the receptacle in front of the dash-board. It is claimed that this device permits easy motion of the vehicle and absolute control, together with ready steering qualities. An American invention of somewhat similar description is the International Motor Wheel, which is, briefly, a single forward drive wheel, carrying on its frame a double cylinder gasoline motor and its fly-wheel. The frame may be clamped to the front of any vehicle, which may be steered by a brake-wheel working on a spur gear. One advantage of the device is that no reverse contrivance is necessary; the wheel needing only to be turned completely around in order to back the carriage when the motor is started.

The American Bicycle Co. recently put on the market a three-wheeled carriage—the "Trimoto"—capable of seating two persons and giving a speed of twelve miles per hour. As in the last-named contrivance, the motor, as well as the gasoline receptacle, are slung on the frame of the forward single wheel. Steering and motor control are both achieved by a single lever coming to the driver's hand over the dashboard.

The Conditions for Good Traction and Steering.—Such machines as above described work very well on good and level roads, but, as a general principle, hanging the motor in front involves insufficient traction and causes the forward wheel to skid even on slight hills, when the weight is mostly over the rear axle. In the early days of motor carriage construction it was commonly believed that overloading the rear, or drive-wheels, involves skidding, whereas the reverse is true, and at the present



FIG. 59.—Front-Driving Brougham of the Electric Vehicle Co., used in New York City. This model, which is no longer manufactured, represents a construction very suitable for city service, but quite inappropriate for country and general use.

time the rule is to make them carry the greater part of the load, in order to promote traction. It is obvious, then, that the rear axle is most logically the drive axle, since, when ascending hills the bulk of the weight must come upon it on any theory of construction. Moreover, it must also properly be the load-carrier, since, as has been frequently demonstrated, any attempt to place the greater weight in front only complicates difficulties. Carriages constructed to carry the load on the front axle have frequently exhibited the tendency to slip sideways, particularly when the brake has been suddenly applied. It has not been an

uncommon thing that such carriages would turn completely around on a greasy street, when propelled by sufficient power to cause the wheels to slide. It has also been found that any arrangement that will prevent slipping forward will also do away with the danger of slipping sideways. Hence, a well-loaded rear driving axle may be considered a permanence, not to say a practical necessity in motor carriage construction.



FIG. 60.—A Winton Touring Carriage, 1901 Model. This is one of the several excellent types of American motor carriage using a hand wheel for steering.

CHAPTER FIVE.

THE UNDERFRAMES OF MOTOR CARRIAGES.

Frames for Motor Carriages.—In general, it may be said, the problems involved in the construction of motor carriage underframes are comparatively simple. They must embody lightness and strength, firmness and some flexibility, and sufficient solidity to resist the destructive effects of motor vibration. The last-named consideration is of particular importance in the construction of gasoline carriages, but is to a certain extent true also of steam carriages, since even with the best-constructed engine of the latter variety, the long-continued stress of vibration is liable to produce strain and breakage, if not properly calculated. In other particulars the frame of a horse-drawn vehicle is fairly typical, except in so far as the conditions involved in mounting a motor necessitate consideration of new centres of resistance to strain.

Horse Carriages and Motor Carriages.—The general situation as regards the constructional relations of the underframes for horse carriages and motor carriages has been summed by Mr. Woods, as follows: "The trouble has usually been that engineers, electricians and mechanics have been the original authors of the automobile, and their minds have been so concentrated upon the development and perfection of the mechanical and electrical parts that they have entirely ignored the artistic side of it. This was undoubtedly brought about by the indifference and skepticism, as well as opposition, offered the advancement of the motor vehicle from legitimate carriage manufacturers, to whom such men refrained from going for advice. There is no question but that this problem belonged to the carriage manufacturers, and, had they taken hold of it in time, they would have preserved to themselves an industry which they rightly had earned by prior experience and conceptions as carriage producers. * * * * Another point of construction is bicycle tubing, or tubing of that nature, for frame work or running gears—in other words, bicycle

construction for supporting the carriage and its weight, as compared with regular and well-known carriage methods of construction. Tubing can, without doubt, be made strong enough, but that is not the question altogether. We must have the entire carriage construction in such shape that it can be repaired by the same class of artisans, blacksmiths, etc., that is now employed by the carriage-makers throughout the country. * * * * *

A motor vehicle should be constructed in all of its iron work, its running gear and axles, the method of putting on its springs, etc., as nearly as possible after the methods now in existence in the carriage world, using, as far as practicable throughout the vehicle, standard carriage hardware. In this way the purchaser of an automobile has a resource at his own door for such repairs as he may need from year to year in addition to his regular painting, varnishing and trimming repairs."

Steel Tubing Framework.—There are two principal objects sought in the use of tubular framework for motor carriages—strength and lightness. These desiderata, which are possible in cycles only with this style of construction, are less prominent in automobiles. Thus it is that, while the majority of European machines still adhere to its use, there is a strongly-marked tendency in America toward angle iron frames, and even more familiar combinations. By the use of brazed joints tubular framework is rendered immensely strong; for, as is asserted by numerous bicycle authorities, breakage practically never occurs at the joints. But to properly repair damage requires the insertion and brazing of fresh tube lengths, which, itself, involves special facilities. Another objection, obviously to be derived from existing tubular structures, is that the advantages gained, in point of combined strength and lightness, are very largely neutralized by the necessity of extra bracing and greater complexity, quite readily escaped with the use of angle-iron framework. Thus it is that Mr. Woods, as above quoted, can assert that tubular framework in a 4,900 pound electric cab saves only about 200 pounds weight, while, as we may readily discover, the desirable end of simple structure is not particularly advanced. Furthermore, the æsthetic considerations of the situation are rather against a prac-

tice necessitating the use of clumsy-looking pipes, when lighter structures can quite as readily subserve the same ends.

The Stanley Tubing Underframe.—The Stanley underframe, used in the "Locomobile" and several other steam carriages is one of the most representative constructions of its class. As shown in the accompanying figure, the front and rear axle shafts are inserted into straight cross tubes, which are brazed to arched cross tubes, intended to lend additional strength and serve as supports for the longitudinal reach tubes. These reach tubes, two in number, are swivel-jointed to the arched cross tubes, as

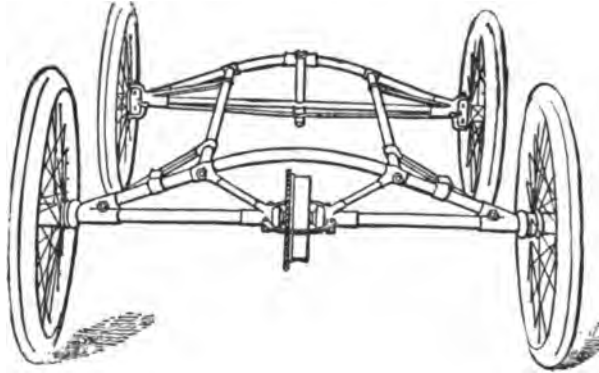

FIG. 61.—The Stanley Type of Underframe used on the "Locomobile" and several other Carriages.

shown, and further secured in place by stay pieces swiveled at the four corners of the frame and ring—jointed loosely on the reach tubes. This construction permits some flexibility on rough roads. The rear cross tube is divided at the centre to admit the sprocket and brake drum, with the contained differential gear. As additional security the two ends are rigidly joined to the arched tube by perpendicular stay rods, and connected together by a nearly circular guard plate surrounding the sprocket and brake drum. The forward arched cross tube supports the forward spring, which is fixed transversely under the body of the carriage, and in front of the vertical axis post of the steering lever. The rear springs are arranged longitudinally on either side of the carriage, being bolted to the seats shown half way on the curve

of the rear-arched cross tube. The boiler and engine, as may be seen in a later figure of the "Locomobile" carriage—and this is the most approved arrangement for motors of every variety—are disposed within the body, beneath and to the rear of the seat, forward of the rear axle. This arrangement overcomes many difficulties involved in attaching them direct to the underframe, and is perfectly practicable; since the springs, in compression, move in a line tangential to the circumference of the sprocket wheel, thus merely shifting the radial line between the sprocket wheel and pinion, and enabling the chain to transmit the power without interruption. This could not be the case were the motor

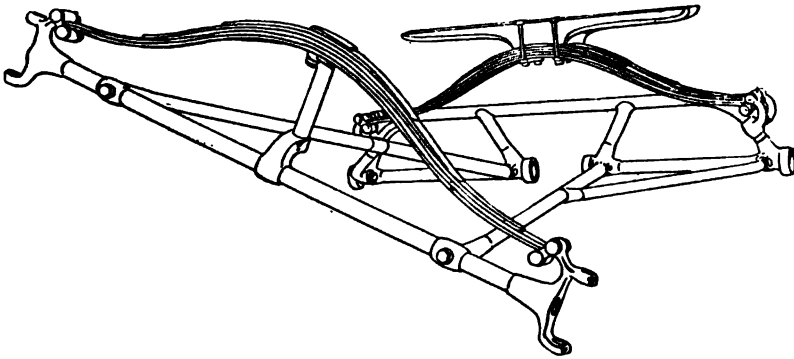

FIG. 62.—The Flexible Underframe of the Reading Steam Carriage.

suspended immediately above the sprocket, nor would the effect of steady driving be any better achieved by suspending it on the underframe below the springs, as is still done by some manufacturers.

The Reading Tubular Frame.—Another tubular frame, also intended for steam carriage use, is shown in the accompanying figure. In it, as in the Stanley frame, there are transverse axle tubes at front and rear, the latter being similarly divided at the centre for the sprocket and brake drum. The longitudinal reach rods, however, instead of running parallel and at right angles to the axles, are disposed so as to form a nearly complete triangle, with the forward axle tube as the base and the sprocket near the apex. The joints on the forward axle are swiveled, and on the

rear axle are ring pivots, so as to permit the distortion shown in the figure on rough or uneven roads. The stay rods at either side of the reach tubes, joining them to the rear axle tube, are also pivoted, as shown, thus assisting the flexibility, while increasing the strength. The forward arched cross tube of the Stanley frame is replaced here by a semi-elliptical spring, while the same feature

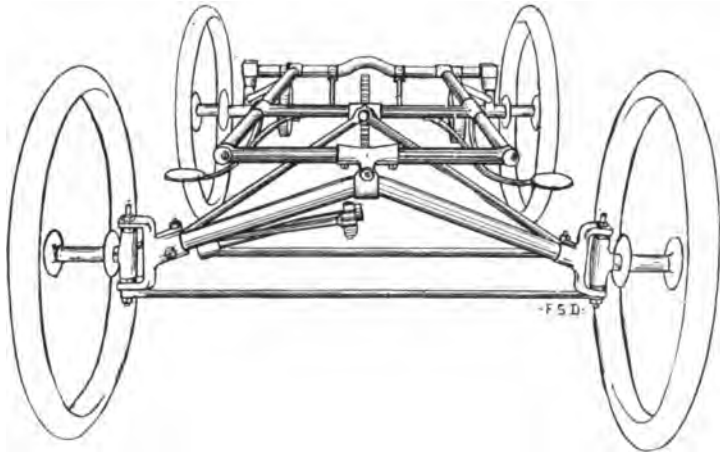

FIG. 63.—The Tubular Flexible Underframe of the McKay Carriage, showing the double swivel jointed front axle.

on the rear axle is here made continuous with the axle bearings, to which are brazed the centre-divided axle tubes, the three being connected and brazed to stay rods. The rear spring, also semi-elliptical, is jointed to the arched cross tube near the rear axle bearings. The rear axle shaft, however, is rigid with the carriage body containing the motor, so that no distortion of the kind pictured can interfere with the steady drive.

Other Flexibility Devices.—Several other carriages attain the end of a flexible and distortible underframe by a three-point support and a swivel joint at the centre of the forward axle shaft. This gives the same general effect on uneven roadways, as is shown in the figure of the Reading carriage, allowing the four wheels to run on different planes, but, as is held by some authorities, it is not as efficient in absorbing undue vibration, as some system of jointure involving a four-point support. It has, how-

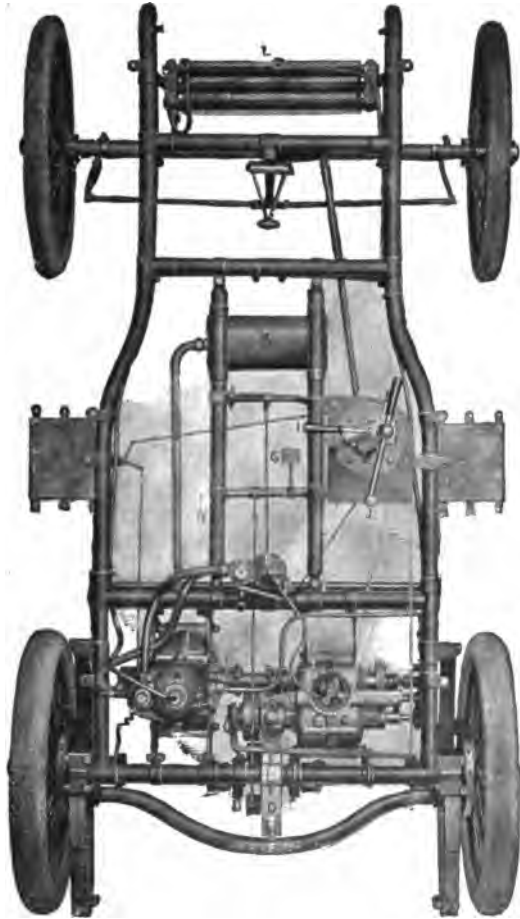

FIG. 64.—Plan of the De Dion & Bouton Underframe and Running Gear, showing the motor and mechanism in position. A, Motor; B, Vaporizer; C, Change of Speed; D, Differential; F, Curved Axle; G, Auxiliary Brake; I, Variable Speed Controller and Brake; J, Steering Handle; K, Muffler; L, Radiator.

ever, been adopted with apparently good results in carriages of all descriptions. The "Steamobile" steam carriage has the reach rods coming together in an angle to the front of the frame, and swiveled at the centre of the forward axle shaft in a yoke, which carries the axle and allows it even greater play in passing over obstructions than is possible even with other methods of swiveling. In this carriage the forward spring is of the usual elliptical construction, placed transversely, or parallel, to the axle shaft,

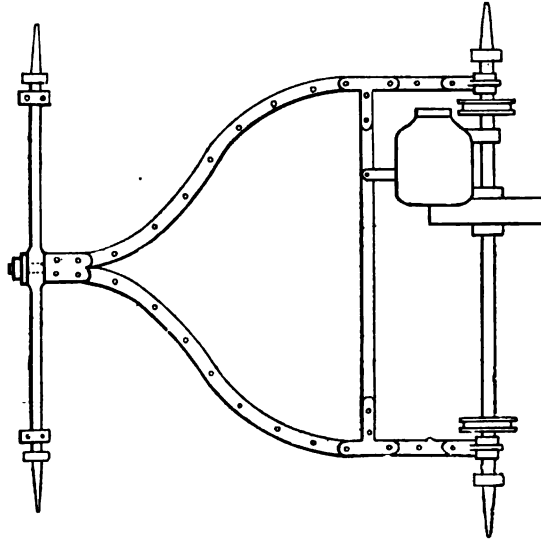

FIG. 65.—Angle Iron Underframe with swivel joint at centre of front axle.

and attached at the top of the swivel yoke. This arrangement is fairly typical of the usual three-point support construction, and has been frequently criticised, because one spring must absorb all the jar incident to the raising or lowering of the wheels. One make of electric carriage, manufactured in Buffalo, N. Y., uses the centre-swiveled forward axle shaft, to which are attached elliptical springs at either side, running with the length of the frame. The result is that, by the use of extra flexible springs, vibration is so reduced as to permit the use of very small rubber tires, while in no way diminishing the effect of a flexible frame.

The Riker Underframe.— One of the best known devices for securing a flexible underframe is embodied in the Riker electric carriages. The construction is of seamless steel tubing throughout, and includes two axle shafts and a cross bar, all parallel in the width of the frame, and two longitudinal reach tubes, each bent inward and carried forward toward the front of the carriage,

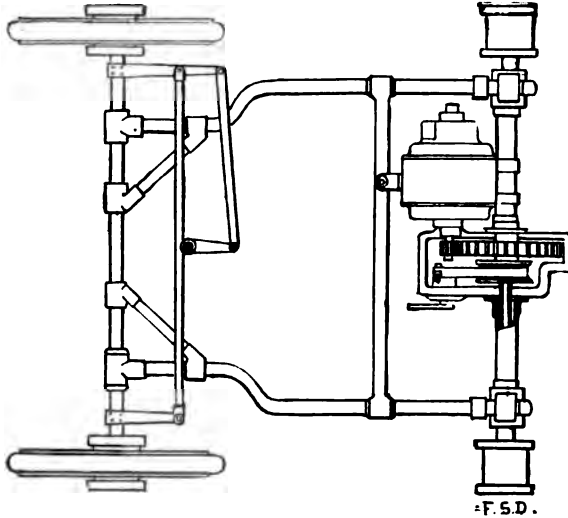

FIG. 68.—The Riker Underframe, showing the swivel connections at front and rear to permit distortion on uneven roads.

thus forming a rectangle of diminished width at the front end. Both the reach tubes are ring-jointed over the forward axle tube; one being securely brazed in place, the other, with its attached stay tube being free to turn, so as to admit of raising or lowering the axle shaft, without straining the frame. Both the reach tubes have their rear ends inserted in bosses below, and cast in one piece, with the bearings for the rotating rear axles being held in place by collars in front and screw nuts at the rear. These bosses are thus true bearings, permitting a certain rotary movement of the reach tubes in the effort to accommodate the axles to any unevenness in the roadbed. The contour of the frame is maintained by binding collars at the jointure of the movable reach tube on the forward axle, and by the transverse cross tube at-

tached midway in the length of both. As shown in the diagram of this underframe, the motor is suspended between the rear axle tube, which forms a sleeve over the rotating centre-divided axle, and the midway cross tube, already mentioned as forward of the axle shaft. The effect of a steady drive is obtained by attaching the motor and gearing at the same side of the frame with the rigidly attached and braze-jointed reach tube, so that the flexibility which permits a certain degree of distortion in passing over

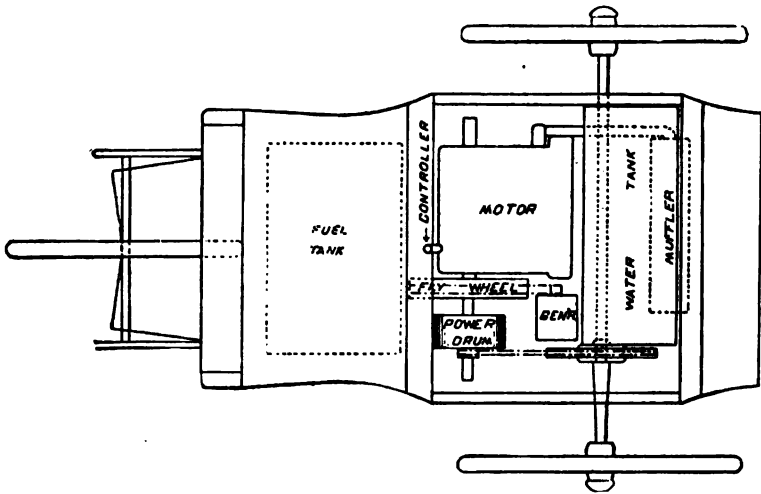

FIG. 67.—Plan of the Duryea Three-wheeled Phaeton, showing the body frame used as attachment for all working parts, dispensing with the underframe entirely.

uneven roadbeds, through the loose attachments of the opposite reach, in no way interferes with the interaction of the driving gears. Herein, we see a fundamental constructional principle for a flexible motor carriage frame; that the flexible and distortable portion should involve only that the forward and rear axle shafts may be so twisted as to move on different planes, thus insuring the stability of the carriage body, while, at the same time, maintaining the motor and drive axle in a fixed and invariable relation.

Dispensing with the Underframe.—The tradition has become so fixed among builders and users that an elaborate and strongly-constructed underframe is indispensable to an efficient

and easy-running automobile carriage that any proposition to dispense with it altogether will likely be scouted as impracticable. As a matter of fact, however, one of the most efficient makes of American gasoline carriage—the Duryea Power Co.'s phaeton—avoids the added weight and strength of the frame by the simple device of hanging the axles directly on the springs support-



FIG. 68.—Duryea Four-wheeled Trap. This carriage, like all others made by the Duryeas, has no underframe; the strongly built body serving as a frame to which the axles and springs are hung.

ing the body, which is unusually strongly and heavily built. This practice, following closely on the general plan of light horse phaetons, enables the use of a heavier motor and body, with all the involved advantages, while at the same time allowing the full use for driving of much of the power ordinarily absorbed in propelling a heavily-built running gear. The needed effect of flexibility is secured by extra long and resilient springs, a semi-elliptical pair running longitudinally over the rear axle shaft, and a semi-elliptical single spring running transversely over the forward

shaft. The accompanying diagram plan of the Duryea three-wheeled carriage and the view of a four-wheeler display the constructional points to advantage. As we shall see later these are the same in both, excepting on the forward wheels.

Three-Wheeled Carriages.—While most of the best known makes of motor carriage run on four wheels, like ordinary horse-drawn vehicles, there are several arguments

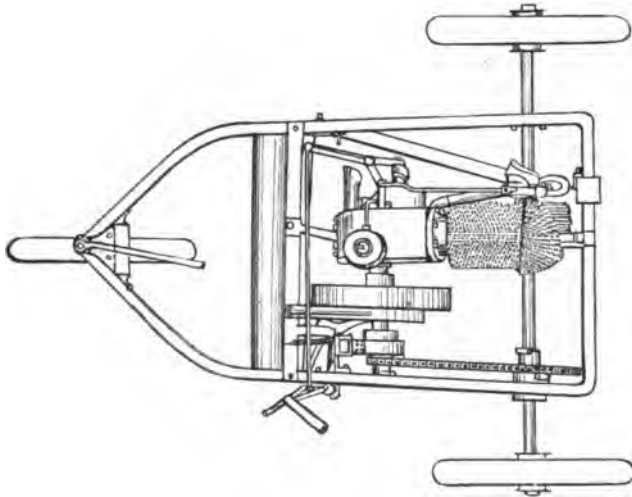

FIG. 69.—Angle Iron Underframe of the Knox Three-wheeled Gasoline Phaeton, showing motor and gearing in position, also steering connections.

in favor of using three-wheelers. One of the most prominent constructional considerations is that the principle of "three-point support" largely, if not altogether, does away with the necessity of a flexible underframe to adjust the wheel levels on uneven roads, with the result that, as is claimed by one manufacturer, there can be no "unequal strains in the frame, tending to break or twist it, or disalign the machinery." All the advantages of a rigid frame, which, as we have already seen, must be in some way combined with a flexible frame, in order to obtain an invariable relation between the motor and the drive axle, are thus possible without sacrifice of other qualities equally essential. It is claimed, however, that three-wheelers are more liable

to upset than are carriages with four wheels, which would very likely be the case were an attempt made to elevate one rear wheel at too great an angle. But, as may be readily understood, a four-wheeler would be no more stable under such unusual conditions, which would tend either to upset the carriage or twist the underframe entirely out of shape. There is some show of reason, then, in the assertion that a three-wheeler will travel on any road



FIG. 70.—The Knox Three wheeled Gasoline Phaeton, showing angle iron underframe, three-point support and steering connections.

passable to a four-wheeled carriage. For, provided the carriage be properly designed, and the proportions of breadth, length and height, the weight of the machinery and body, and the distribution of the load be accurately calculated, the danger of an upset in passing over any inequality that a sensible driver is capable of attempting would be exceedingly remote.

Advantages of Three-Wheelers.—In a letter to the “Horseless Age,” Mr. Charles E. Duryea, of the Duryea Power Co., says: “The writer is free to predict that the future popular two-passenger carriage will be a three-wheeler, because of the many advantages which only need to be known to be appreciated. We are running three and four-wheelers of the same design, side by side over all kinds of roads in this locality, and know by actual comparison that the three-wheeler is preferable in most cases. We

submit that actual tests are stronger proofs than theories." In the same letter he says further: "The three-wheeled carriage, if properly designed, rides as easy as a four-wheeler, or so nearly so that the difference cannot be told by a blindfolded observer riding in the two alternately; while the three-wheeler steers more easily, requires less power to propel, starts and stops more quickly, is simpler, lighter, very much better in mud and appreciably better everywhere else." In another letter on the same subject he says:



FIG. 71.—Duryea Three-wheeled Delivery Wagon. This wagon is built on the plan shown in Fig. 67.

"While we supply four-wheelers to those buyers who do not wish the three-wheeler, we are confident that the three-wheeler is the best machine of the two, and have demonstrated the same many times by actual comparison. There is one less tire to watch, fewer parts to look after, less weight to carry, one less track, and consequently less road friction, which means less fuel, less heat, less noise." It has also been claimed that three-wheeled carriages have the additional advantage of vibrating less on rough roads, some claiming a decrease in this respect on a ratio of 3 to 4. But this is not so certain, according to other findings. The manufacturers of the Knox gasoline three-wheeler, which is enjoying an increasing popularity in some quarters, evidently consider their own machine, at least, highly efficient in this respect. They say: "We use the principle of *three-point support* * * * wherever possible, the frame being supported on three wheels, the engine being attached to the frame at three points,

and the body being mounted on the frame by three springs. Rough or uneven roads have little power to harm such construction."

Steering Gear of the Knox Carriage.—With the use of four wheels, as we have already seen, ready and positive steering may be attained by observing a few simple and obvious constructional principles, prominent among which is the requirement of keeping the balance of leverage as near the axis of the wheel as possible. This end is made even more practicable with a three-wheeled vehicle by hanging the forward single wheel on a fork, after the manner of an ordinary foot-propelled bicycle. Such a course is actually followed in the Knox carriage, for which the manufacturers claim "easy and reliable steering" with the following advantages: "The steering action is the same as in a bicycle that can be ridden 'hands off'; closest possible connection from hand of operator to steering wheel; entire absence of levers and connections to cause lost motion or trouble to operator; the vehicle will turn in a nine-foot circle under its own power; very short turns may be made at high speed without danger of capsizing." Even with all the excellent features above enumerated, it is doubtful if the method of controlling the steering wheel by a lever attached direct to the pivot of a swinging wheel is altogether the best construction for a motor vehicle. For, as is evident on reflection, a hand lever of sufficient length to give the steerer a positive turn, without using too much strength, will describe an arc of such dimensions as to annoy the riders and often necessitate long reaches. It is possible that some form of worm gear and pinion device would achieve all the excellent results claimed without the difficulties involved in a long lever.

Duryea's Steering Head.—The steering wheel of the Duryea three-wheeler is not hung in a fork, but turns on an axle shaft attached to the two curled bars extending to the front of the carriage body. In all respects, therefore, the three-wheeler of the Duryea Co. differs from the four-wheeler only in the fact that a single wheel is thus attached, instead of the semi-elliptical spring, carrying a through axle for two knuckle-jointed wheels. The steering head is an ingenious and highly efficient device,

which has been in use on these carriages for nearly four years. As shown in the diagram, the forward wheel has twelve spokes mounted on mortises on a malleable ring, in which are screwed hardened steel ball cones, provided with a locking device for fastening after adjustment. This malleable ring when mounted revolves on a ball race, containing thirty three-eighth-inch balls, which is screwed to the cylindrical steering head. At the top

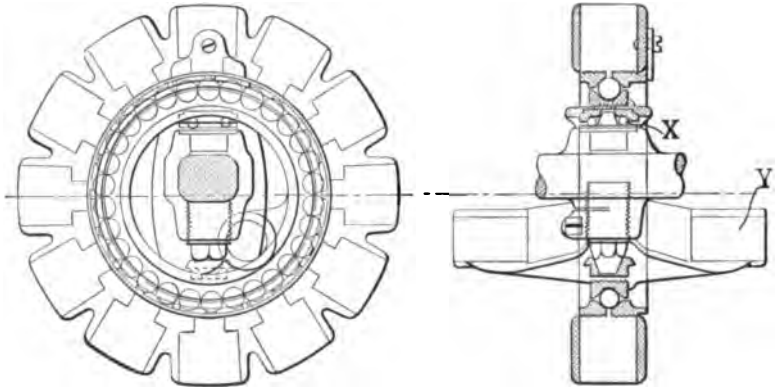

FIG. 72.—Steering Head of the Duryea Three-wheeled Carriages. X is the support of the wheel which turns on the ball race shown. Y is the attachment of the steering links.

and bottom of the steering head are mounted hardened cups for the steering pivot cones, the one fixed permanently, the other adjustably in the cross bar or support, which carries the front end of the vehicle. As shown in the diagram, the upper cone may be screwed in or out to adjust the bearing at this point. It is held in place by a clamp, while the lower cone generally turns on balls, as shown. By this arrangement the steering pivot is brought directly into the plane of the wheel, as in a cycle, so that there is no jar on the steering lever, or need of unusual effort on the part of the driver. Moreover the arrangement is highly efficient in ensuring a constant direction, particularly when traveling on level roads, a point highly desirable in a pleasure carriage.

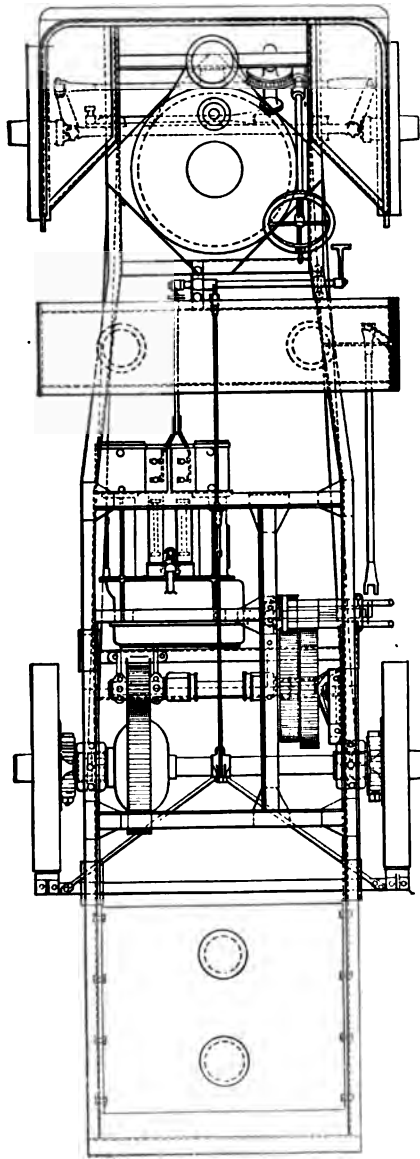

FIG. 73.—Plan of Body and Underframe of Thorncroft Long Frame Lorry. The dotted lines between the axles indicate the reaches which constitute the underframe.

The Present Situation on Frames.—Some of the foremost manufacturers of motor carriages at the present time hold to the conviction that an elaborate underframe is rather a useless complication than an advantage in any sense. This means that, as is being increasingly understood, the same framework may serve for the body, the motor and the running gear, giving a combination that is lighter and stronger than where two or three separate



FIG. 74.—One Model of the Stearns Steam Carriage, showing the perch rods of hickory wood, which give a much more flexible frame than steel tubes, without the numerous difficulties involved in the use of swivel joints.

frames are used, besides saving space, material, labor, care and repairing, and increasing the neatness, while decreasing the weight and the cost. The body must be mounted on springs, and it is the best construction, particularly where high speeds are contemplated, to mount the motor in the body. In his statement that the experience of carriage builders is preferable in the matter of underframes, to that of bicycle builders—for it was entirely from bicycle precedents that tubular framework was ever adopted—Mr. Woods seems to be in accord with several other authorities. Even with the most carefully planned tubular frame the stiffness

of the construction is poorly compensated even with the use of swivel joints, and some of the best known makes of motor carriage with tubular frames are constantly giving trouble from this cause, involving constant damage and consequent repairs. On the other hand, it must not be forgotten that, unlike both carriage and cycle, the automobile is a locomotive, and that, as such, its peculiar conditions demand constructions to which no former experience is precisely analogous. In no matter more than underframes is it so essential to bear this distinction in mind, and in no point is it so apparent that the ultimate or permanent type of motor carriage will depart quite entirely from the precedents of horse-drawn vehicles. In a letter to the author, Mr. C. E. Duryea says: "The use of steel wheels and tubular construction is an outgrowth of cycle experience, but engineers make a mistake who attempt to apply their experience indiscriminately to carriages, for the carriage problem is not a single-plane problem. Both the cycle and its wheels receive strains, and in a single plane, while cycle riders save themselves and the machine by standing on the pedals on rough spots. The automobile rider never does this, while the constant torsions and wrenchings of a four-cornered frame are simply indescribable. On this account a three-wheeled construction is much longer lived and will undoubtedly prevail in the end."



FIG. 74a.—An American Gasoline Vehicle, equipped with side spring frame, after the fashion of several models of horse carriage. This style of underframe is very suitable for light motor carriages, overcoming many of the disadvantages of the usual spring constructions.

CHAPTER SIX.

SPRINGS AND COMPENSATING DEVICES; RADIUS RODS AND JOINTED SHAFTS.

Springs for Motor Carriages.—Like all varieties of vehicle at the present day, automobiles have the body suspended from the axles or underframe on suitable springs. With them, also, the usual function is subserved, absorbing and counteracting jars and cumulated vibrations incident on roughness in the roadway or a high degree of speed. In the present state of the motor carriage industry, there are few data regarding the proportions and construction of springs, best suited for different purposes; the matter being largely one of empirical considerations and practical experiment. We may readily understand, however, that motor carriages, being intended primarily for high degrees of speed, involve conditions and considerations found in neither horse-drawn vehicles nor railroad cars. The latter, although traveling at speeds often 100 per cent. greater than the average automobile, run upon an even and comparatively unresistant roadway—the track of steel rails—while the former, although built for the ordinary highways, as are automobiles, are seldom calculated for any but very moderate rates of speed. Railroad cars must, thus, provide against a maximal speed, with a minimal road roughness and resistance; horse carriages, on the other hand, must provide against a maximal roughness and resistance with a minimal speed; motor carriages must be able to attain high speeds and, at the same time, resist the annoying and destructive effects of roadways, inevitably irregular as to resistance and other conditions of surface. As a general proposition, therefore, we may assert that such springs as will promote comfort will prevent undue wear and tear on the motor and parts, which, in fact, makes the end of easy riding for the passengers the prime consideration.

The Theoretical Working Unity.—In no part of construction is it more essential to consider the road and the vehicle as a working unit than in the matter of calculating for springs, and in

no point is there a greater element of uncertainty and a greater variableness in running conditions to render all calculations unreliable and inexact. The general situation is well expressed in a recent article on motor vans in the *London Engineer*, which speaks as follows :

“The prime fact with which engineers have to deal is that the success or failure of any design mainly depends on the nature of the road on which the van is to be worked. The V-slides of a planing machine are integral parts of the whole. The permanent way of a railroad and the rolling stock constitute together one complete machine. In just the same way the King’s highway must be regarded as an integral part of all and every combination of mechanical appliances by which transport is effected on the road. In one word, if we attempt to dis sever the road from the van, we shall fail to accomplish anything. Two or three years ago, the maker of a steam van told us that he was surprised to find how little power was required to work his van. He had been running it on wood-paved streets. A week or two later on he was very much more surprised to find that on fairly good macadam after rain he could do next to nothing with the same van. In preparing the designs for any van, the quality of the roads must not for a moment be forgotten; and it will not do to estimate the character of the road by anything but its worst bits. A length of a few yards of soft, sandy bottom on an otherwise good road will certainly bring a van which may have been doing well to grief. Curiously enough we have found this apparently obvious circumstance constantly overlooked. This is not all, however. A road may be level, hard, and of little resistance to traction, and yet be very destructive to mechanism. This type of road is rough and “knobby”; it will shake a vehicle to pieces, and the mischief done by such roads augments in a most painfully rapid ratio with the pace of the vehicle. Jarring and tremor are as effectual as direct violence in injuring mechanism. Scores of examples of this might be cited. One will suffice. In a motor van a long horizontal rod was used to couple the steering gear to the leading wheels. The rod was broken solely by vibration. It was replaced by a much heavier and stronger bar. That was broken in much the same way, and finally guides had to be fitted to steady the rod and prevent it shaking.”

Points on Spring Suspension.—As regards the suspension of springs of horse-drawn vehicles and automobiles, the careful observer will note one point of divergence at once. When elliptic, or semi-elliptic, springs of the ordinary description are used, he will see that in most light horse carriages only two are suspended, one over each of the axle shafts, across the width of the carriage. In automobiles of every build and motive power, while a single spring may be thus attached to the forward axle, the rear axle supports two, one at each side of the frame, and running in the length of the carriage. This is a construction found only in the heavier patterns of horse drawn carriages, and in both cases it is resorted to for the purpose of neutralizing the forward lunge of the body, inevitable on rough roads with a single trans-

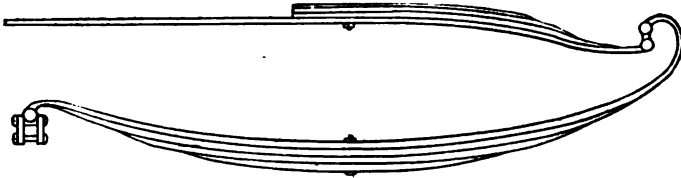

FIG. 75.—Scroll Bottom Carriage Spring, half elliptic, showing connections by links and shackles.

verse elliptical spring. With the horse carriage of the heavier pattern such vibration is annoying and also hurtful to the body, frame and springs. With the automobile, however, the case is even graver; for not only will similar results follow at high speed, but the proper distance between the motor, usually carried in the body above the springs, and the rear axle will be continually disturbed, with consequent damage to sprocket, chain and gears and loss of a steady drive. Thus, in carriages which have no other provision against this tendency of the rear axle to throw backward or forward under the stress of travel, it is necessary to use a device known as a distance rod to maintain a fixed distance between motor and drive axle, when the throw of the springs would otherwise permit it to be disturbed. The better method of overcoming this danger is to set the springs in the length of the carriage, as just described; for thus most of the violent jars in this direction are absorbed, and the fixed relation of motor and axle maintained, without rigid attachments, which would form

another notable occasion of accidents. This allows the springs to lengthen under pressure from above or from the direction of travel, and further reinforces against sidewise lunges, which, however, are of far less frequent occurrence. With the use of transversely arranged elliptical springs on both axles similarly troublesome conditions in the steering mechanism would result; the turning of the steering lever frequently compressing the spring sufficiently to make steering uncertain, and the numerous jars of the vehicle on a rough road or at high speed often tending to check its operation altogether.

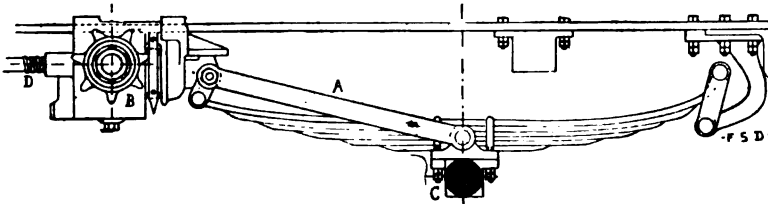

FIG. 76.—Spring and Radius Rod of the Mors Carriages. The rod, A, maintains a fixed distance between the sprocket pinion, B, and the wheel axle, C, even when the springs are constantly in action. This carriage also has a device for varying the distance between the countershaft at B, and the engine pulley, by sliding the entire shaft forward or back under impulse from the screw, D. The spring, being hung on links at front and rear, has considerable play, up and down, without disturbing the fixed relation of the axle, C, and the counter-shaft, B, as determined by the radius rod, A.

Dimensions of Springs.—Of the four varieties of springs used in vehicles of various kinds—extensible spiral, compressible spiral, coiled, and laminated leaf springs—the last-named has been found by all odds the most suitable for automobiles in point of easy riding, if in no others. Such springs, which are composed of a number of leaves or laminæ of steel, can be made in proportions suitable for light or heavy loads, by varying the size and number of the layers, without involving the jolts and vibrations inevitable in any but the heaviest structures of the other descriptions. However, apart from certain well ascertained figures on the static weight of the load and the size and tensile strength of the springs designed to carry it, there are no reliable data regarding the proper proportions of springs for automobile carriages. As we have said, this is, and must continue, a matter to be governed most largely by experiment, apart from mathematical calculations, since the constantly varying conditions of automobile travel

preclude exact theory. Among these variants may be mentioned high speeds on any and every kind of road and the use of pneumatic tires. The matter is still further qualified by the size of the tires and the degree of inflation, for both of these points are important in modifying the stress to come upon the springs. Indeed, there is no more important factor in the high speed motor vehicles than the rubber tires, although the properties developed in its practical operation by no means permit its use on vehicles without suspension springs of some description.

The Effects of Pneumatic Tires.—The use of pneumatic tires on a vehicle permits the absorption of considerable vibration and the consequent use of softer springs than are possible with steel tires. One reason for this is that pneumatic tires, after violent or unusual compression, do not rebound, as even the best springs will do; whence only a minute portion of the total shock is transmitted from them to the springs. On the other hand, however, they have a certain bouncing motion of their own, which is imparted to the running gear, and will occasion an annoying back-jolt, unless suitable springs are interposed. This is entirely neutralized by the use of properly adjusted springs, although in the matter of adjustment we must consider the size and degree of inflation of the tires, the weight and dimensions of the springs, and the average speed used. In some respects a heavier spring gives easier riding than a light one, since the latter is apt to bounce disproportionately, even with good pneumatic tires, when the road is somewhat rough. In this matter some authorities make a direct comparison with the action of pneumatic tires on bicycles, whose ease of riding at high speeds has frequently been found to be a consideration not only of the road surface, but also of the degree of inflation of the tires. The severity and quality of the jars received under stated conditions is, therefore, typical in these particulars of the stress brought upon the springs set over the pneumatics in an automobile.

As the reader or any careful observer may readily conclude from the facts, pneumatic tires, if properly inflated, while a great factor in easy traction, are by no means the sole requirement. While they absorb much vibration unavoidable in steel-tired vehicles, without springs, they do not wholly set aside the rule

that it is exceedingly bad construction not to suspend motors and other heavy freight. As has been frequently learned at considerable cost, rubber tires will not prevent broken axles when the motor is hung below the springs. For this reason many manufacturers use, not only additional springs for the seats, but also doubly suspend the moving parts, such as boilers and engines in steam carriages, or storage batteries in electric vehicles. Frequently, however, this additional precaution acts to neutralize the effect of the springs by aggravating jolts instead of allowing them to be properly absorbed as would otherwise happen.

The whole situation, as regards the relation of springs and pneumatic tires, may be understood by reference to common experience with bicycles. As is generally known, unless certain

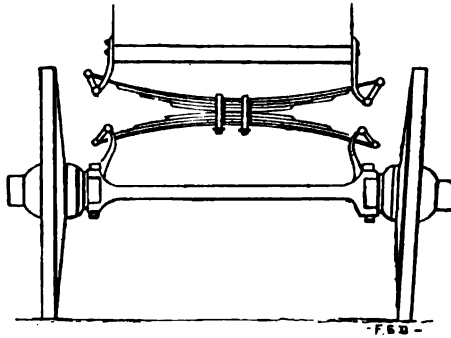

FIG. 77.—Forward Axle of the Jeanteand Electric Carriage, showing double half elliptic springs with connections by links to frame and body.

ascertained rules are observed regarding both the inflation of the tires and the method of riding, the rider is liable to experience a series of annoying jolts and vibrations on the best-made roads. Thus, while the rear, or drive-wheel tire, is usually inflated until very hard, the forward tire is allowed to remain considerably softer. By this means are avoided the vibrations which inevitably follow when both are pumped hard. The rider soon learns, also, in passing a street crossing or a hollow in the road-bed, to raise himself on the pedals, in order to escape a shock of considerable severity. To partly obviate this necessity and "make all roads smooth," several makes of bicycle have what the manufacturers call a "cushion frame," consisting of a flexible spiral

spring inserted in the tubular support of the saddle post. The result is that the rider is greatly relieved of shocks and vibrations, the spring acting to absorb most of the bounding action of the tires. Nor has a similar result been otherwise successfully achieved, although it has been claimed by some bicyclists that the annoying jolts, due to a hard forward tire, are greatly reduced when a moderate load or a child is carried on the handle bars. Imperfect inflation of the rear tire is apt to strain and loosen the spokes, while only slightly modifying the annoying effects of travel on uneven roadways. The bearing on the situation of automobile construction is obvious. For, since the passengers cannot mitigate such shocks by any changes in position or distribution of the load, properly proportioned springs are the only resort.

Condition of Spring Dimensions.—In judging of the dimensions and elasticity of springs suitable for carriage use the limit of elasticity must be carefully considered with relation to the static and maximum loads to be carried by the vehicle. The static load is the dead weight of the vehicle body and frame, together with that of the passengers and other freight, estimated when at rest. The maximum load is the proportionately increased weight of the same items, with relation to the traction effort required when the vehicle is running at its highest speed, under test conditions as to road roughness or hill-climbing requirements. Similarly, the ultimate load is the greatest weight possibly carried with good spring action. That the springs should be calculated to retain the elasticity, or have the ultimate strength far beyond the maximum load, is obvious, when we consider the office of a spring in any aspect. In calculating the proportions of springs in the best constructed railroads, it is usually customary to consider the maximum load as twice the static load. Whence it is the general practice to estimate the fitness of a given spring for its work as equivalent to the quotient of the weight of the spring divided by the product of its length, between the extremities of the longest leaf, and the number, width and thickness of the other several leaves. The variable nature of carriage roads makes the proportion of static and maximum load much higher for horse-drawn vehicles than for railway cars, except

where only the most moderate speeds are to be used, but for automobiles, always calculated for high speeds, it never falls below a ratio of 1 to 3, and is often estimated as high as 1 to 5. As has been pointed out by several authorities on the subject, the difficulty of obtaining springs for automobiles, which shall be serviceable under all conditions, is greatly aggravated when the weight of the body, motors, etc., is very much in excess of that of the passengers provided for. This is true, since a spring that will subserve the end of easy riding under usual conditions, with extra heavy accessories of this description, would permit

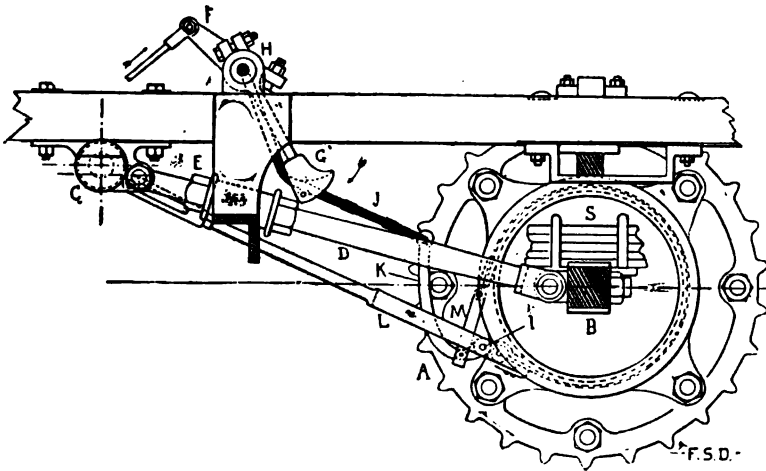

FIG. 78.—The Sprocket and Spring of a Panhard Carriage, showing the adjustable radius rod for maintaining the distance between sprocket and pinion at a determined distance when the springs act.

no end of jolting and annoying vibration at high speeds on imperfect roads. The fault is difficult to discover except under test conditions. For this reason builders have frequently attempted to counteract the uncertainties of spring action by using extra springs on the seats, somewhat after the fashion of those used in some rough farm and draft carts, where no springs at all are used between the body and the axletrees.

As a general rule, also, such seat springs modify the practical rules usually followed, permitting the use of even lighter springs to support the body. To sum up the general requirements in a

few words, we may say that, while the pneumatic tires will often absorb vibrations, thus permitting soft and light springs under the body, the occasional inequalities in the road are apt to occasion a quick succession of annoying jolts, reaching by accumulated forces almost to the limit of spring elasticity, or succeeding one another so rapidly, at high speed, that the springs have little time to recover their normal shape. This seems to indicate that a heavier spring is preferable, or else that spring construction must be in some way varied to give firmer attachments and more evenly distributed elasticity; the time required by the spring to recover itself being the same under all conditions, some springs are thus unfit for high speed work. Many manufacturers prefer semi-elliptical springs to the full elliptical on the ground that their elasticity is greater for a given weight of spring, and the consensus of opinion on the latter is that the longer the spring, within reasonable limits, the greater the combined elasticity and lightness. When such springs are used as side supports it is general practice to attach one end direct to the longitudinal frame and connect the other by a link, thus allowing ample freedom toward lengthening. When placed transversely over the forward axle both ends are secured to links, the centre being securely clamped.

Attachments for Springs.—The ends of ready lengthening and extra elastic support are also accomplished by the use of what are known as scroll elliptics and semi-elliptics, wherein one leaf of the spring is extended somewhat at one end and turned over, like a rolled scroll, to be connected to its mate or to the carriage attachment by suitable links or other joint. Links are preferable in many places on account of the ready action allowed in several directions, without involving tendency to yield unduly under ordinary conditions. The high speed requirements of motor carriages makes it nearly imperative that leaf springs, either half or full elliptic, should be securely clamped to the supports by clips and nuts, rather than by bolts through bolt holes in the centre. This is true because such bolt holes are liable to prove a source of weakness under high speed conditions and to cause the breaking of springs at the very time when their full strength is most requisite. With clips this danger is wholly avert-

ed, and, instead of a weak point at the centre, an additional rigidity and re-enforcement is obtained.

One of the most efficient arrangements of springs for high speed carriages is that found in the Jeanteaud electric car and one or two motor carriages of American make. Two semi-elliptical leaf springs are clamped together at their centres, leaving the two extremities of the upper one in position for attachment to the carriage body, and the two extremities of the lower one in position for attachment to the axle. Links are then bolted at all

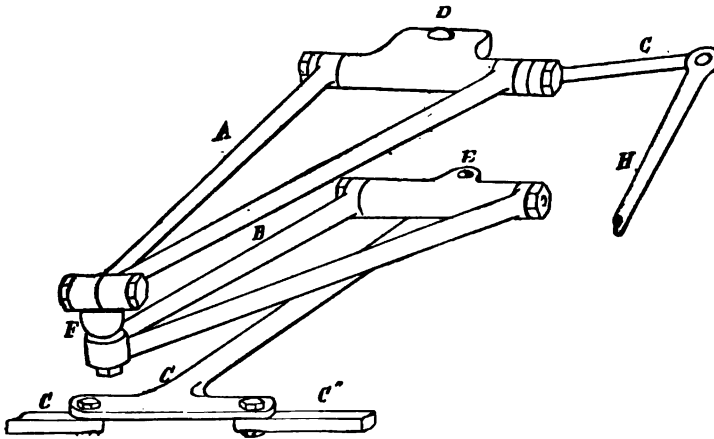

FIG. 79.—The De Dion & Bouton Spring Compensating Steering Device. The V-shaped piece A, constructed of two pieces, as shown, is attached to the tubular front cross-piece of the body frame at D, and pivoted on the ball joint at F, to the lower V-shaped piece, B. This is also pivoted at F, and is attached to the axle-tree at E. The T-piece, C, is also pivoted at E rigidly with B, so as to turn sideways with it. It carries the links C' and C'', which actuate the steering arms of the two stud axles. The link, H, is attached to the arm, G, and when moved forward or back by the worm gear and pinion arrangement at the base of the steering-wheel pillar, moves the entire structure, A, B and C, on the pivots, D and E, to the right or left, as desired. The object of the device is to allow of a certain up and down movement, as the springs yield, without disarranging the steering gear or vibrating the steer wheel. In such cases the V-pieces, A and B, move on the ball joint F, thus permitting the points, D and E, to be approached and separated, as the springs move.

four points in order to suspend the springs so as to permit the greatest freedom of motion laterally and allow for considerable compression.

Construction of Springs—The leaf springs used in road carriages and railroad cars consist of several layers of steel plates or leaves more often slightly bent, so that, when laid together, they

are found forming superposed arcs of so many concentric circles. It is essential to a serviceable spring of this description that the line of the arc be carefully followed from end to end of each plate, and that no attempt be made to straighten or bend back the extremities of the longest leaves. This is true because the spring effect is derived from the temper of the metal in permitting the load to flatten all the arcs at once under a single stress, which involves that they should slide upon one another in altering their shape, as could not be the case were there any such departure from the line of the arc, as has been mentioned. In that case the several plates would tend to separate and "gape" under a load requiring a degree of compression tending to bring the extremity of any arc to the straight portion of the top leaves. The

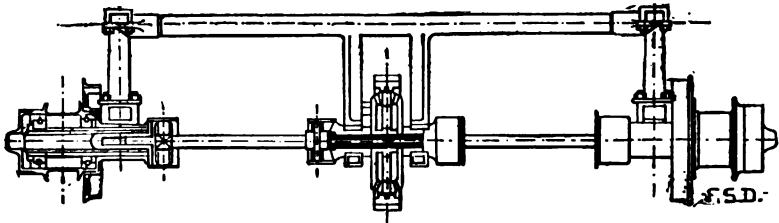

FIG. 80.—Jointed Rear Axle of the De Dion & Bouton Carriages. By the use of universal joints between the driving spur and wheel spindles a steady drive may be maintained between the spur, hung on the body, above the springs, and the wheels, below the springs, even on the roughest roads, when the springs are constantly in action.

result would be a loss in spring action, and a probable source of breakage on occasion. In constructing laminated leaf springs it is essential that the plates should decrease on a regular scale of lengths, in order that the structure may be of equal strength throughout and of sufficient flexibility for the loads calculated to its dimensions. Where such a spring is thick, consisting of a number of plates, it is a good working rule that the ends of each several plates should touch the sides of a triangle, whose base is drawn between the extremities of the longest plate and whose apex is at or about the theoretical centre point of the spring's movement. This means that, with a well-proportioned spring in its normal shape, the end of each separate plate should be equidistant from that of the one immediately above it and of the one immediately below it. By this construction even distribution of stress is attained without waste or resistance from inactive

portions of the length of each plate, as would be the case in a laminated spring flattened at the top plate and having the longitudinal profile shaped to an arc. Such a spring, however, would embody bad construction in another particular, since it would neglect one very essential feature of spring construction—curvature of the plates. This curvature is intended to represent the difference between the spring under static and maximum load; at the latter point its leaves should be nearly straightened under stress; beyond that point, as they are bent backward and downward, the point of ultimate strength, involving loss of elasticity and breakage, is rapidly approached. It follows, therefore, that the end of a perfectly elastic and serviceable spring is best attained by such curvature as will allow bending of the plates from each extremity of the top plates, on the support at the centre,



FIG 81.—A De Dion & Bouton Gasoline Carriage.

without involving endwise compression, as is the case when the curve approaches a semi-circular contour. Consequently, laminated leaf springs, as a usual thing, are constructed to an arc of never more than ninety degrees and often very much less.

Rules for Calculating Springs.—Although as a general proposition, the usefulness of a spring for given work and load is strictly a consideration of the total length of the structure between points of attachment, the thickness and number of the leaves, and the quality of the steel used—the last-named consid-

eration is of the utmost importance—there are certain formulæ followed in railroad work, and to a certain extent, in carriage designing, that are useful to the practical automobile builder. As given in several works on locomotive and car construction, they may be summarized as follows:

Let *B* represent the breadth of the plates in inches.

Let *T* represent the thickness of each in sixteenths of an inch.

Let *N* represent the number of plates in the spring.



FIG. 82.—A Stearns Steam Runabout, showing side steering lever, solid underframe and the method of arranging the springs.

Let *S* represent the working span, or the distance between the centres of the spring hangers, when the spring is loaded.

Let *W* represent the working strength of a given spring.

Let *E* represent the elasticity of the spring in inches per ton.

The elasticity or deflection of a given spring is found by the following formula:

$$1.66 \frac{S^3}{NBT^3} = E \text{ in } 16\text{th inch per ton load.}$$

The span length due to a given elasticity and number and size of plates is as follows:

$$\sqrt[3]{\frac{E B N T^3}{1.66}} = S \text{ in inches.}$$

The number of plates due to a given elasticity, span and size of plates:

$$\frac{S^3 \times 1.66}{E B T^3} = N$$

The working strength, or greatest weight a spring can bear, is determined as follows:

$$\frac{B T^2 N}{11.3 S} = W \text{ in tons (2,240 lbs.) burden.}$$

The span due to a given strength and number and size of plates:

$$\frac{B T^2 N}{11.3 W} = S \text{ in inches.}$$

The number of plates due to a given strength, span and size of plates:

$$\frac{11.3 W S}{B T^2} = N.$$

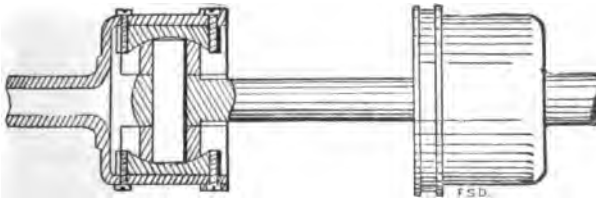

FIG. 88 — Universal Jointed Counter-shaft of the Thornycroft Steam Wagon. This compensating device differs from the De Dion, which is on the axle. The object is the same, to permit of an uninterrupted drive under rise and fall of springs.

CHAPTER SEVEN.

MOTOR CARRIAGE WHEELS.

Requirements in Motor Carriage Wheels.—As summed up by a noted authority on the subject, vehicle wheels must have three qualities of construction: (1) They must be sufficiently strong for the load they are to carry, and for the kind of roads on which they are to run. (2) They must be elastic, or so constructed that the several parts—hub, spokes and felloes, or rim—are susceptible of a certain flexibility in their fixed relations; thus neutralizing much vibration, and allowing the vehicle greater freedom of movement, particularly on short curves and when encountering obstacles. (3) They must, furthermore, be sufficiently light to avoid absorbing unnecessary power in moving. In addition to these qualifications, wheels suitable for automobiles must be able to resist the torsion of the motor, which always tends to produce a tangential strain. This is the reason why tangent suspended wire wheels are invariably used in automobiles, instead of the other variety, having radially-arranged spokes. They must also have sufficient adhesion to drive ahead without unduly absorbing power in overcoming the tendency to slip on an imperfectly resistant road-bed. The importance of the two last considerations may be readily understood in view of the fact that the wheels of motor carriages receive the driving power direct, instead of being merely rotating supports, like the wheels of vehicles propelled by an outside tractive force.

Methods of Constructing Wheels.—In order to meet the conditions above mentioned various devices have been resorted to. Where wooden wheels are used in any kind of vehicle, the effect of elasticity is very greatly increased by “dishing”; that is, by inclining the spokes from the exterior plane of the rim to the centre point of the axle spindle, so as to make the wheel a kind of flattened cone. This construction has the effect of transforming the spokes into so many springs, possessing elastic properties, and renders the wheel capable of being deformed under sideways

stress. The shocks of collision with obstacles are thus distributed through the flexibly connected parts, as could not be the case if the wheel were made in one piece or on one plane, and the consequent wear and strain is greatly reduced. The dish of the wheels is usually balanced by slightly inclining the axle spindle from its centre line, thus bringing the lowest spoke to a nearly

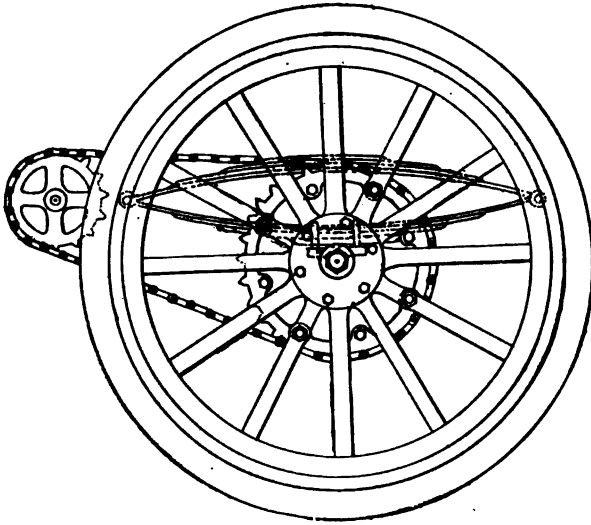

FIG. 84.—Wooden Wheel, such as is used on heavy gasoline carriages of Panhard, Mera and others. It turns loose on the axle and is driven by a sprocket on a counter-shaft.

vertical position with relation to the ground. A great resisting power to shocks produced by obstacles such as is afforded by dished wheels is of far less importance in vehicles designed for good roads, as are most automobiles, which need only such inclination of the spokes as will provide for the even distribution of shocks, and the maintenance of uniformity in pressure.

Advantages Attained by Dishing—The significance of the word “dish” is obvious, when we consider that it indicates a diametrical section of about the shape of a saucer or shallow dish. While, as we have seen, this shape furnishes a very desirable spring effect against sidewise strains and shocks, such as are

met in swinging around a corner or sliding against a curb—since, although a wheel is always weakest sidewise, it is difficult to thrust a cone inside out—there are several constructional considerations that render it a desirable feature for wagons of all descriptions. The first of these has reference to maintaining a balanced hang to the wheel. Under the conditions of travel a wheel acquires the tendency to crowd on or off the spindle, with the result that it eventually wears loose, as may be frequently found particularly on heavy carts. Since the spindle is tapered it is necessary that its outer centre should be lower than the inner, and, then, in order to counteract the outward inclination of the wheel, and consequent tendency to roll outwardly, the spindle end must be also carried forward sufficiently to make the wheel “gather,” which is to say, follow the track. A moderate dish contributes to the end of bringing the tire square to the ground, while at the same time enabling the wheel to rotate without undue wear at the axle. Another constructional advantage involved in the dishing of wooden wheels relates to the method of shrinking on the iron tire. As is known, the tire is first forged to as nearly the required diameter as possible, after which it is heated, so as to cause it to enlarge its diameter and in this state placed about the rim of the wheel. When once more cooled it fits tightly. As frequently happens, however, a tire is made somewhat too small for a wheel, which involves that, in the act of shrinking, it will either force the wheel into a polygonal shape or crush one or more of the spokes. By giving the wheel a dish, the shrinkage of the tires merely increases the inclination of the cone from base to apex, the spring of the spokes being quite immaterial, all suffering to about the same extent.

Wooden Wheels and Wire Wheels.—There are two varieties of construction used in automobiles: the one following the theory of the horse-drawn vehicle, with wrought frame and wooden wheels; the other following the construction of foot-propelled bicycles and tricycles, with tubular frame and wire wheels. However, wire wheels are used on any kind of vehicle, and, following on the practices of the early makers of motor carriages, have gained wide recognition as the typical construction for this purpose. The principal argument for their use is the combina-

tion of lightness and strength such as no wooden wheel can attain. But they lack elasticity and without pneumatic tires are useless for automobiles. Indeed, it seems to be the conclusion of some authorities that the consideration of combined lightness and strength, urged alike for wire wheels and tubular frames, and perfectly proper in the case of bicycles, is of the nature of a superstition, which is hostile to the most advantageous progress in automobile construction.

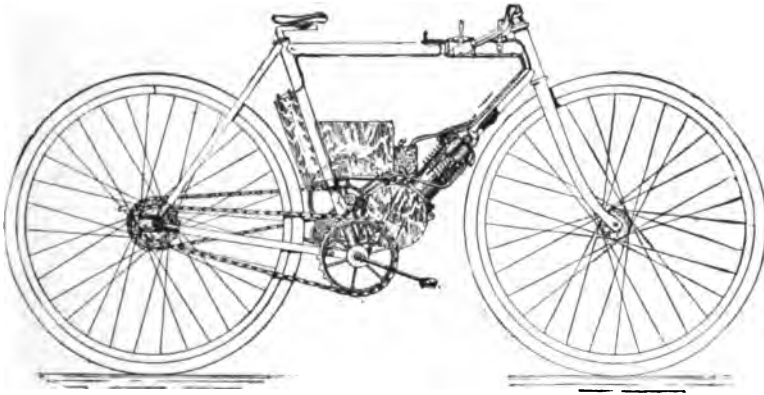

FIG. 85.—A Thomas Motor Bicycle, showing light tangent-spoke wire wheels and one style of mounting the motor.

Relative Merits of Wheels.—In order to briefly state the issues involved in the case of wooden wheels against wire wheels, we may say that the main requirements in any wheel are, not only its ability to sustain a considerable weight in its plane, but also its power to resist sidewise strains. Now, while it is widely conceded that a wire wheel will sustain a greater load than a wood wheel, the two being considered weight for weight, it certainly will not sustain as great a strain sideways, which represents the line of the wheel's greatest weakness. A wire wheel driven against a curb with sufficient force will have its rim dented, with the result of loosening all its spokes and ruining it. A wooden wheel, on the other hand, may have a gap in it and still be serviceable. It may even run with one or several spokes broken off. A wire wheel being suspended on its spokes—the load being hung be-

tween the hub and the perimeter—is bound to suffer in proportion to the number of points of suspension lost. A wooden wheel, being supported at both hub and perimeter by its spokes, has a certain power of compensating or distributing the strain, so that, while a deficiency of support is no advantage, it does not always involve destruction.

Disadvantages of Light Construction.—On the point of using tubular frames, C. E. Woods asserts that for an electric cab weighing 4,900 pounds only 200 pounds is saved, while the total strength is no greater than with wrought bar frames of suitable dimensions. Moreover, he alleges, that tubing is a positive detriment from the fact that ordinary blacksmiths and wagonwrights cannot repair it, and, consequently, that in case of accident one must always resort to the manufacturer. A similar line of reasoning is applicable to wire wheels, which involve the danger of crystallizing the wires by unequal strain or adjustment; of crushing the rim, by running on a deflated tire; or, of “buckling” the spokes by collision with a curb-stone or another vehicle, always with the result that others than road-side smiths must be called on for repairs. The sum of Mr. Woods’ argument is that only such constructions should be used as may be everywhere readily handled by skilled mechanics.

The Use of Wood Wheels.—Mr. Charles E. Duryea, in a letter to the “Horseless Age,” argues ably for the use of wooden wheels, with the following statements of advantage: (1) The construction, proportions and strength suitable for given requirements have been carefully determined by years of practical experience. (2) Being practically one piece, they do not deteriorate by usage in bad weather and are readily cleaned. (3) If broken, they may be anywhere repaired, all the parts being easily obtainable. (4) They will often give good service even in a badly damaged condition. (5) Experience has shown that they are far more elastic than wire wheels. (6) In wire wheels any attempt to make the hub of proper length to give spread to the spokes under strain results in a clumsy appearance. (7) If the spokes are proportionately strengthened the wire wheel becomes heavier than the wood wheel. (8) The greater number of spokes in a wire

wheel, and their proximity at the hub, where dirt and moisture are collected, prevents easy cleaning and promotes rust. On the point of elasticity Mr. Duryea says: "As a matter of fact, the wood wheel is far more elastic than the steel wheel, as may be readily seen by watching a light buggy drive over car tracks or rough pavements. The rims of the wheels vibrate sideways, sometimes as much as two inches, without damage to the wheel or axle, on which account fewer broken axles will be had when



FIG. 86.—Haynes-Apperson Gasoline Surrey, one of the best-known makes of American motor carriage using wooden wheels.

wood wheels are used instead of wire ones. While it is true that the pneumatic tire practically removes the necessity of an elastic wheel, there is no need of refusing to accept a valuable feature." On the wagons manufactured by Mr. Duryea's company wooden wheels with pneumatic tires are used with excellent results. His opinions on the subject seem to be shared by a goodly number of motor carriage manufacturers, notably Haynes-Apperson, the New York Electric Cab Co., and the Autocar Co., all of whom are now using wood wheels most largely, if not exclusively.

Dimensions of Automobile Wheels.—The consideration of wheel dimensions is important in automobiles, and in no other particular is it more essential that the relations of size and use be

accurately calculated. In horse-drawn vehicles the forward wheels are made of smaller diameter, in order to allow them to cut under the body in turning. This consideration precludes the possibility of making the diameter sufficiently large to ensure all-around easy running, except by the use of high frames or long axle shafts. In automobiles, on the other hand, the forward wheels may be of any convenient diameter; since by the use of knuckle-jointed steering axles a wide angle of turning may be obtained without using a pivoted axle shaft. As a general proposition we may assert that the larger the wheel the smaller the shocks experienced in passing over inequalities in the road bed, and the smaller the buffing qualities required in the tires. Thus it is that a wheel five feet in diameter will sink only one-half inch in a rut one foot wide, while a thirty-inch wheel will sink nearly three times as deep, with the result that the resiliency of its tires must be enormously larger, in order to compensate the greater shock experienced. The larger wheel also rises less quickly over obstructions. These are considerations of great importance in motor vehicles, in which any device for the reduction of vibration and concussion is desirable. Furthermore, when a wheel is properly tired, the road resistance to its steady and even rotation is decreased as the square of the increase in its diameter, such a wheel of sixty inches diameter decreasing the resistance in a ratio of between 50 per cent. and 70 per cent, as compared with a wheel of thirty inches diameter. There are, however, other methods for neutralizing the shocks on rough roads. For, as experience has demonstrated, the end of obtaining a low and easy-running rig may be achieved quite as well by increasing the width of the vehicle, the length of the springs and the size of the tires, as by adding to the height above the ground. By following this theory of construction, the Duryea Power Co. is able to use wheels of thirty-inch and thirty-six-inch diameter for the front and rear wheels, respectively, and secure a remarkably easy-running carriage. They are adopting, however, a construction which is, in correct proportions, very nearly equivalent to large diameter—the use of broad tires. For, as has been repeatedly demonstrated, the broad tire is superior to the narrow one in the very same particular, that it will not sink so quickly into mud and sand, and, by its greater buffing properties, neutralizes the con-

cussion otherwise experienced with small wheels. Their thirty-eight-inch springs are another potent factor in achieving the desired end.

Practical Points on Wheel Diameter.—While it is no part of the province of this book to reproduce the lengthy and elaborate calculations by which the fitness of wheels of given diameters, breadth of tire and material of construction is to be determined,

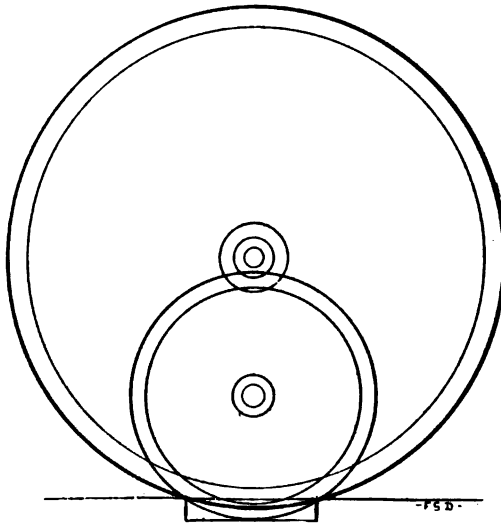

FIG. 87.—Diagram showing the relative drop into a road rut between a small carriage wheel and one twice its diameter.

we may briefly indicate a few of the leading considerations which have moved manufacturers in general to regulate themselves on these points. It is a distinct advantage to enlarge the diameter of motor carriage wheels for the purposes of obtaining an offset to the concussions experienced on rough roads, to obtain higher speed, within certain limits, and to secure greater durability for the tires. The last consideration is of great importance, particularly when hard rubber tires are used. The principles involved are well set forth in a recent article in the "Horseless Age," which contains the following statements: "To prevent traveling on the rim a tire should bind the whole surface of the rim. The higher

the wheel the more adhesive surface there is for the tire. When the tire is bound in by lugs the natural kneading and straining of it between the lugs will in time either shear off the lugs or loosen them. Another reason why a large wheel is to be preferred from a tire-maker's point of view is that a large wheel does not turn round so many times in a given distance, and consequently does not wear the tire so fast. If a tire travels very fast under a heavy load the kneading of it causes heating and crack-

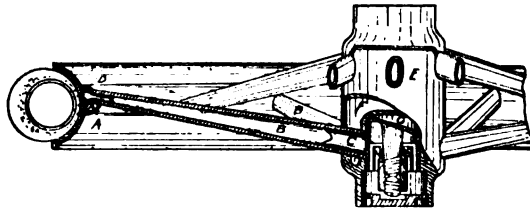

FIG. 66.—Part Sectional View of a Tubular Steel Wheel, used on many automobiles of all powers. Although, to the date of the present writing, the principal issue among authorities is upon the respective merits of wood and wire wheels, this type of wheel is steadily growing in favor. Among the advantages claimed are: superior strength to either wire or wood; true, balanced running, as a pulley on a shaft; practical immunity to rust, on account of the inner and outer brass coating on hubs and spokes and the brazing at all joints; ability to stand the twist and tension of severe strains in the transmission of power; rims formed from a continuous tube; spokes made from high carbon cycle tubing, oval in shape and reinforced at both hub and rim; perfect alignment secured by assembling all parts in jigs. As shown in the cut, the parts are: A, tubular steel rim; B, tubular steel spokes; C, tubular steel reinforcement at hub; D, tubular steel reinforcement at rim; E, outer tubular steel hub shell; F, middle tubular steel hub shell; G, inner hub shell over axle spindle. The method of securing the hub to the axle is also shown. Although, as must be fairly obvious, such a construction admits of very little sidewise spring action under stress of travel or collision, which is a particularly desirable feature in wooden wheels, especially with steel tires, the slant of the spokes effectually prevents such extreme deformation as would tend to disable a wood or wire wheel. The oval shape of the spoke tubes, and their arrangement as regards both hub and rim, enable the carrying of greater loads, in proportion to weight, than are possible with other varieties of wheel. It is also possible to keep such wheels perfectly clean, without risk of injury by rust, as must result from attempts to wash wire wheels, as already stated. Furthermore, tubular steel wheels do not shrink when dry, as do wooden wheels, and, consequently, require no process of soaking to restore them to normal condition.

ing, which are intensified on the small wheel. Our experience has proved that a large wheel greatly reduces the above difficulties."

Troubles with Large Wheels.—As against the above advantages involved in the use of large wheels, there are a number of objections of equal, if not greater, importance. Among these may be mentioned the fact that, the larger the wheel, the greater must be its proportional strength and weight of construction, in order to neutralize the ill effects of torsional motor effort, and

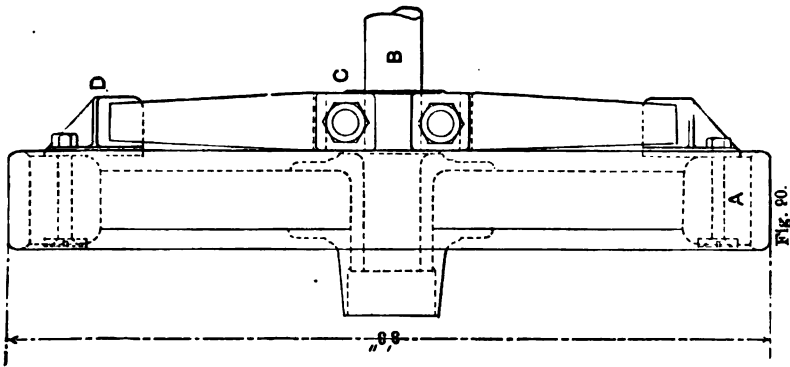

Fig. 90.

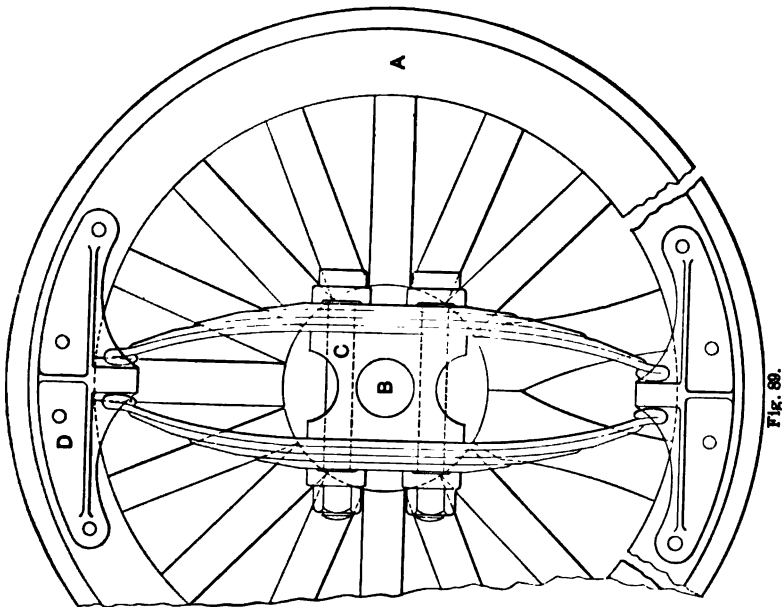

Fig. 89.

Figs. 89 and 90.—Two views of the Thornycroft Spring Drive Wheel. A is the felloe of the wheel carrying the iron tire. B is the revolving axle, which is independent of the wheel except for the springs secured to it by the bolts, C. D is the angle piece at the felloe carrying the lug to engage the springs, as shown.

disproportionate road resistance. Indeed, a moment's reflection will show that a wheel of sixty-inch diameter, built on the same dimensions of hub, spokes and felloes, as a wheel of thirty-inch diameter will possess considerably more than twice the liability to strain and breakage from the causes above named. If we may assert that such increased liability, as compared with the increase of diameter is on a ratio of three to two, it is obvious that a wheel of sixty-inch diameter must be very nearly three times as heavily and strongly built as a wheel of thirty-inch diameter, in order to insure its durability. We may readily judge, then, at about what point of increased diameter a light pleasure carriage would be equipped with cart wheels. This is only one of the numerous difficulties involved in attempting to use large wheels with a modern high-speed motor.

Thornycroft's Spring Drive Wheel.—A driving wheel much like those of the Hancock and Gurney carriages is used on the steam road wagons manufactured in England and America, under the patents of John I. Thornycroft. This device, which is shown in detail in the accompanying figures, consists of two oppositely attached leaf springs bolted rigidly to the end of the rotating rear axle, and following its motions. Immediately in front of these springs is the conical axle spindle, and when the wheel is set the leaf springs engage lugs on the angle pieces bolted to the felloes. The result is that the motive power is transmitted solely through the springs bearing on the lugs, which affords an exceedingly elastic connection on the very circumference of the wheel. Thus reducing the motor strain to the lowest point, it relieves the spokes of all strain beyond the dead load carried on the wagon. In the construction of wheels for this purpose, Thornycroft follows Hancock's wedge model, but utilizes the involved strength and solidity far more effectively. Similarly constructed wheels have long been used on the Huber traction engines with good results, the claim being that the yield of the spring permits the engine to keep moving until the wheel is forced over an obstacle in the roadway.

CHAPTER EIGHT.

SOLID RUBBER TIRES.

The Question of Tires.—All automobiles and cycles, and a large number of horse-drawn vehicles, use rubber tires. The object is twofold: first, to secure a desirable spring effect; second, to obtain the requisite adhesion to the road. While, with properly constructed springs, the first result may be achieved with steel tires, the second is almost impracticable when the power is applied direct to the wheel. Thus, if a light automobile be equipped with steel tires, the wheels will not drive on an imperfectly resistant roadbed, unless most of the load be placed over the rear axle, which, when it is too great in proportion, involves the disadvantage, that the steering will be unreliable, the forward wheels tending to skid, instead of turning the vehicle in a positive manner. It is not always practicable to remedy this difficulty, either by strewing sand in front of the wheels or by applying power to all of them. An attempt to produce adhesion by constructing tires with teeth or corrugations, or by giving them extra breadth, would increase the weight for only temporary advantage. The simplest and readiest resort is found in the use of rubber tires.

The Reduction of Vibration.—On the point of reduced vibration in a vehicle, as it is related to the kind of tires used, W. Worby Beaumont says: "It must also be remembered that the greater comfort of the rider is due to lessened severity of vibration and shock, and this is a relief in which everything above the tires participates. Now, this means a reduction in the wear and tear of every part of the car and motor which can easily be underestimated. The experience of the London cab-owners, whose records of every cost are carefully kept, is a proof of this; and they find that rubber-tired wheels suffer very much less than the iron-tired, every part that could be loosened or broken by constant severe dither or hard vibration remains tight very much longer, the breakage of lamp brackets, hangers and other parts

does not occur, and that even the varnish, which being hard and breakable, lasts a great deal longer. The same immunity of the high-speed car is obtained by pneumatics, as compared with solids, and its value is greater in proportion to the greater value of the vehicle." It may be readily understood that, if such a consideration is of importance in horse-drawn vehicles, it is even more so in the case of automobiles, whose parts are subjected to strain both in traveling on rough roads and also from the vibration of their own motors. This is particularly true of carriages driven by gasoline engines, in some makes of which the vibration is often excessive, generally increasing in direct ratio to the speed at which the carriage is propelled. Hence, without some kind of buffing properties at the tires, disaster must soon follow.

Rubber Tires for Automobiles.—There are two varieties of rubber tire in use for every kind of vehicle except cycles; the solid tire and the pneumatic, or inflatable tire. As is generally known, the pneumatic tire was first devised in order to furnish the needed resiliency in bicycles, and for the same purpose it has been found useful in automobiles, particularly in connection with wire wheels. It has, however, one notable disadvantage—the constant liability to puncture—with the consequent danger of being made useless. In order to remedy this defect inventors and manufacturers have introduced such features as thickening the tread of the tire, increasing its resistance to puncture by inserting layers of tough fabric in the rubber walls, and even using small metal scales.

Merits of Solid Tires. — From the standpoint of durability solid tires are the best beyond question, not only for heavy service, but also for high-speed light cars. The combined effects of speed and weight work less rapidly upon them, enabling a greater mileage endurance than with the best pneumatics. Indeed, it is the verdict of very many authorities that the lowest mileage records have been obtained with the use of high-priced pneumatics. Such tires, however, contributing a greater ease of travel in most of the ordinary designs of racing vehicles, are used by persons eminently well able to afford the involved additional ex-

pense. Consequently, the relative merits of the extremes are quite immaterial to the general public. Commenting on the statements of a writer who contended that the question of tires suitable for various kinds of vehicles is largely an open one, Mr. C. E. Woods writes as follows: "The writer's own experi-

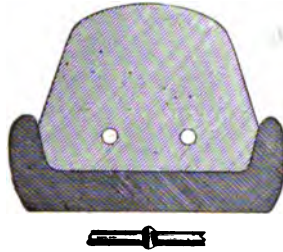

Fig. 91.



Fig. 92.

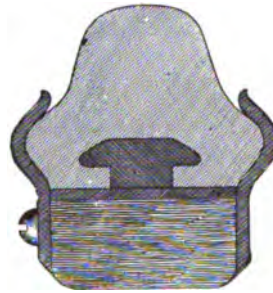

Fig. 93.

FIGS. 91, 92 and 93.—Three varieties of Solid Rubber Tire, showing shape and methods of attaching on the rims. Fig. 91 shows a broad tire, which is attached by forcing over the edges of the channel-shaped rim, to which it is vulcanized, and also secured by endless wires, welded, as shown. Fig. 92 shows a tire secured by bolts through the base, also by annular lugs on the rim sides fitting into channels. Fig. 93 shows an attachment made by connecting at the base by a peripheral T-piece, also by bolts securing sides of channel-shaped rim. All three varieties show rim channels, so shaped as to allow of considerable distortion, laterally, under load.

ence has been very different in its results. . . . After the construction of a few vehicles, early in his development of them, on which he went through the same experience indicated by Mr. Condict's article, he adopted the hard or solid rubber exclusively, and designed diameters of wheels, width of felloes, etc., to accommodate such sizes of tires as by experience proved best suited to the many and different styles of vehicles to be built. For he had discovered that the resiliency of pneumatic tires was entirely lost

when the carriage was properly designed and the weights properly distributed on its points of support, and the latter placed on properly designed springs. The easy-riding carriage for any purpose depends entirely upon its springs for this qualification, and there is no reason why the automobile, with its heavier weight, should be any exception to the general rule. If, however, carriage design embodies the placing of a set of batteries (in electric vehicles) over one set of springs, making a very unequal distribution of the load—which in itself is always a faulty design—it cannot be expected to be easy, and a very large and not too

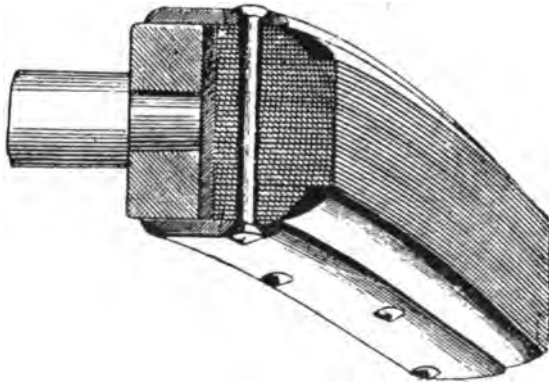

FIG. 94.—Indurated Fabric Solid Tire. This tire is constructed, so as to prevent rents and cuts across the tread, by inserting strips of tough fabric around the perimeter, so that the edges are brought into contact with the ground. Where clear rubber would yield, the fabric holds secure. The tire is attached by bolts through the base, as shown.

much inflated pneumatic tire may help the difficulty a little. But even then when tires are inflated to the pressure necessary to give an economical power effect, there is scarcely any more resiliency left in them than that given by a hard rubber tire, and their unsightly and objectionable appearance, as applied to a general carriage production, is too well known to need comment here.”

Comparative Values of Tires.—On the points here made, Mr. Woods seems to have the support of several experts in the matter of tires, although there is a widespread agreement that pneumatics are the only suitable ones for high-speed, high-power vehicles. Mr. Beaumont writes as follows: “For high-speed run-

ning with comfort over street crossings and level railway crossings, the expensive pneumatic is necessary, but it is a high price to pay for this luxury, and it will only be paid by the few who will pay anything for speed. After a while, when automobile travel settles down to the moderate speeds of the majority, and to the requirements of business, the better forms of solid or nearly solid tire, in which a comparatively small amount of internal movement of the rubber takes place, will probably be most used. A hard pneumatic tire is superior to this for ease at the bad places in roads and over crossings, but greater strength of material suitable for the purpose than is yet available is required to meet all the conditions."



FIG. 95.—Solid Rubber "Sectional Tire," having the tread divided into a number of tooth-like sections, all attached in one piece to the rubber base, as shown, in order to give greater distortion endwise under load, thus allowing of considerable cushion effect. It has been claimed that the construction permits of real resiliency.

Durability of Solid Tires.—From the standpoint of lessening the vibration of running, and thus preventing considerable damage to the vehicle, Mr. Beaumont concedes that pneumatic tires are preferable, although, from considerations of durability, he prefers the solids. As to the life-period of solid tires, under constant use, he says: "With regard to solid tires, the experience of the London hansom cabs is of much interest. A pair of $1\frac{1}{8}$ or $1\frac{3}{4}$ inch tires will last from a little over six months to, at most, nine months. The most rapid wear is on those cabs which have the best and fastest horses, if we except those cabs that have constantly to run in districts where the road surfaces are destroyed by the prevalence of tramways, those expensive metallic admissions of the badness of the ordinary roads, and of the incompetence and penny-wise policy of most of the road authorities. If

thirty miles per day for the hansom driven by men who are, as most are, allowed two horses per day, and assuming 300 days per year, then a year's mileage would be 9,000. They run, however, not more than eight months at best before tire renewal, so that the mileage is not probably more than about 5,500 to 6,000. . . . The mileage of the tires on the four-wheel cabs is much greater, as would be expected, from the smaller weight each wheel carries and the lower speed. The miles traveled per month will also be less."

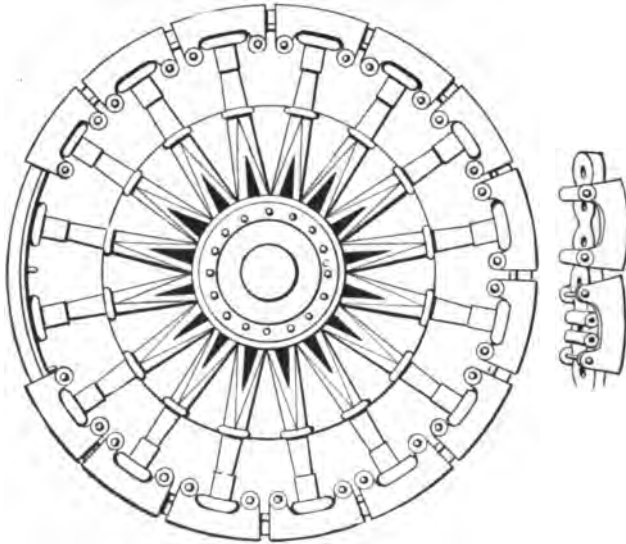

FIG. 96.—Wheel of the "Lifu" Steam Truck, showing a solid rubber cushion tire secured in position and protected by metal shoes around the rim. Although the attachment is so rigid as to prevent creeping, a very effective spring effect is obtained by combination of the cushion tire and shoes. It is effective for heavy service, which would soon destroy an ordinary solid tire.

Structural Requirements in Solid Tires.—The shape and methods of attaching solid tires to the wheel rims must both be determined with reference to the source and pull of the strains likely to affect them. The weight of the vehicle is nearly the greatest source of wear, but even this consideration is closely rivaled by the torsional strain from the engine and in braking, particularly in view of the almost universal use of comparatively

small wheels. Indeed, no part of the wheel could suffer greater strain than the tire from the condition last mentioned. In view of the properties of rubber it may be readily seen that increasing the thickness of the solid tire, in proportion to the increased weight of the vehicle, will largely neutralize the destructive effects due to every cause involved in the structure of the running gear and its load. By this means is obtained a greater width of tread, with a probably smaller total abrasion of the surface from contact with the road bed, and a greater opportunity for distributing and neutralizing the harmful strains.

The tendency in solid tires is that cuts, due to stones or other sharp obstacles, tend to spread to the centre of the tire across the tread. This is due to the quality of the strains transmitted from the wheels, as above noted, and, in order to prevent this tendency from destroying the tire it is necessary to vary the shape. Accordingly, tires are made with bevel edges, rather than on square lines, and the profile is slightly rounded. This conformation, together with good width at the rim, is able to provide for absorbing much of the surplus vibration, while decreasing the ill effects due to the combined action of a heavy load and road resistance. On the whole it greatly prolongs the life of the tire. The curved surface at the tread and the bevel edges, tending to flatten under the load, provide a sufficient width to ensure good adhesion and the other advantages belonging to a wide tire, while, at the same time, reducing to the minimum the tendency to spread tears and cuts, as above mentioned.

Methods of Attaching Solid Tires.— There are several methods of attaching solid tires to the rims, as is shown by the accompanying figures. In these typical structures the rim carries flanges at either side to retain the tire, or else these flange pieces are bolted to the felloes. The tire is also retained in place, either by a suitable shaped T-piece running around the circumference of the rim, by wires drawn up to the proper tension and electrically welded at the ends, or is simply vulcanized to the rim. The last-named method of attachment is recommended by several writers on the subject.

CHAPTER NINE.

THE USE AND EFFECT OF PNEUMATIC TIRES.

Advantages of Pneumatic Tires.—As against the opinion of Mr. Woods, that the solid tire is preferable for all types and weights of motor vehicles, most authorities still maintain that the numerous advantages gained in the use of pneumatics cannot be dispensed with in automobiles, nor obtained by the use of any other devices. One very valuable quality of a pneumatic tire is its resiliency, or the ability to bounce in the act of regaining its normal shape after encountering an obstacle in the road. On encountering such a small obstacle as a stone, a pneumatic tire will yield to a certain extent, absorbing or “swallowing it up,” at the same time exerting a pressure sufficient to restore its normal shape after passing the obstruction. This quality begets two advantages for easy driving: It does away with much of the lifting up of the wheel in passing over obstacles, which is otherwise inevitable, and also enables the tire to obtain a better grip on the road bed. Commensurate advantages are also derived from this cushioning quality in colliding with obstacles to one side or other of the tread; whence the total pressure exerted through the spokes is greatly reduced and such obstructions exert only a fraction of their usual power to retard the easy and steady operation of the motor and steering gear. In both cases, also, a large part of the shocks and vibrations, usually transmitted direct to the springs, are completely absorbed. No solid tires could furnish anything like such advantages in operation: the usual result, even with the most flexible springs, being that the motor is much shaken or damaged, or its action largely impaired. This is particularly true of the use of solid tires on electric vehicles, the damage resulting, both in point of efficiency and durability, having been estimated by several authorities as high as 30 per cent. As against this estimate we have the above quoted experience of Mr. Woods, himself an expert and manufacturer of electric vehicles. But that it is possible to supplement to a degree the imperfect cushion qualities of solid rubber tires, by the use of

well-suspended springs, seems to be suggested by the report on another American make of electromobile, as published in the "Horseless Age." The writer there states: "The springs used on this machine were extremely flexible, so much so that the solid tires were extremely small, and the writer understands that the company intends to use steel tires next year." No data, however, are accessible on the durability of the motors used, nor on the behavior of this exceptional machine on rough roadways.

Speeding Qualities of Pneumatic Tires.—As has been already suggested by several quotations, the peculiar properties of pneumatic tires are nowhere of greater advantage than under high speed conditions. Since speed is one of the principal considerations with both builders and users of automobile carriages, another source of the pneumatic's popularity may be recognized. On this point the observations of Mr. J. W. Perry, a tire dealer of Paris, are significant. He says in a letter to the "Horseless Age": "Automobile builders, in the course of competition with each other, have sought to make or build machines of great speed, and each year has brought us a stronger motor, with increased speed, until we see now motors of 35 horse-power that attain speeds of 90 and 100 kilometers an hour (56 to 62 miles). No solid tires could stand such speeds, and only pneumatics of the very best make can stand such strains. I have made tests with 2½ and 3 inch solid rubber tires on automobiles ranging from 16 to 24 horse-power, and on carriages weighing 1 ton to 1½ tons. After many careful tests, I ascertained that both of these automobiles could run safely on a good road at a maximum speed of 42 kilometers, 25 1-10 miles, an hour. When the driver attempted to go beyond this speed (always on a perfect road) the motor was subjected to such fearful vibrations that it threatened its complete demolition. Under the same conditions of horse-power, weights and tires, but on what is considered a bad road, it was impossible to attain more than 15 miles an hour. The same autos, with pneumatic tires made 60 and 70 miles an hour on an average road." While it is perfectly true that the average automobilist never contemplates such high speeds as Mr. Perry mentions, it is only fair to indicate that speed, combined with general road qualities, merely furnishes the test conditions for

the jar-absorbing, vibration-neutralizing, and adhesion-increasing properties of pneumatic tires. Furthermore, as the result of numerous experiments, it may be correct to assert that a tire, best fitted to endure test conditions as to speed, is also within certain limits the most suitable type and make to travel under heavy loads, with a minimum of traction effort. For, as most figures seem to indicate, the decrease of traction effort is in ratio with the elasticity of the vehicle's support.

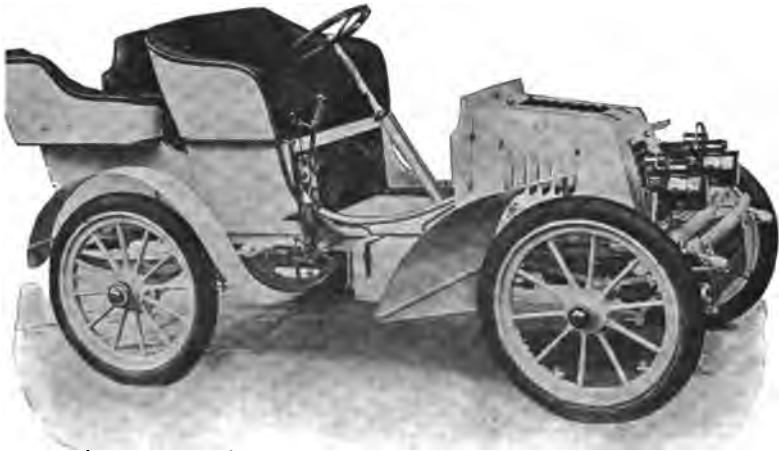

FIG. 97.—A "Peerless" Touneau Touring Car, equipped with wooden wheels and broad pneumatic tires. This cut furnishes a good object lesson on the size of pneumatic tires required for large weight, high speed motor carriages.

Economic Efficiency of Pneumatic Tires.—In a paper read before the International Automobile Congress held in 1900, Michelin, the well-known French tire-maker, gave a number of statistics relative to the efficiency of pneumatics, as compared with solid rubber and metal tires. His experiments are interesting as showing how the efficiency of the pneumatic tire, in point of traction economy, increases directly as the speed of the vehicle. Using an electric wagon, weighing 1,980 pounds, on a level Macadam road, and driving through a distance of 1,000 meters in each case under a uniform pressure of 80 volts, he obtained the following figures on traction effort: When running against the wind, with iron tires, 53.9 amperes; with solid rubber tires,

48.5 amperes; with pneumatics, 44.2 amperes, representing a gain of 10 per cent. for the solid rubbers, and of 18 per cent. for the pneumatics, as compared with the iron tires. When running with the wind, other conditions being the same, the figures were: With iron tires, 50.1 amperes; with solid rubber tires, 45.2 amperes; with pneumatics, 41.1 amperes, representing a gain of 9.8 per cent. for solids and of 18 per cent. for pneumatics, as compared with the iron tires. The average speed in both cases was 7.31 miles per hour. At a speed of 12.31 miles, he obtained a per-

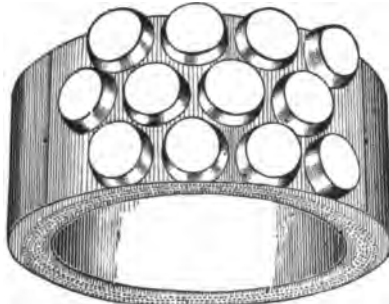

FIG. 96.—The Bailey Single-Tube Pneumatic Tire. The tread is covered with conical projections, which prevent slipping, and at the same time promote traction. According to the claims of the manufacturers, puncture is also made a more remote possibility.

centage of gain 13 and 28, respectively, for solids and pneumatics; the wind, however, being unfavorable during the test of the iron tires. Nevertheless, on a slightly muddy road, he registered respective gains of 10.8 and 20.5, running with the wind at a speed of 12.5; and on a good road bed at a 4 per cent. grade, 1.7 and 7.8, for a 1,210 pound wagon at 6.87 miles. On a 5 per cent. grade covered with "sticky mud," the solid tires showed a loss of 4.7 per cent., and the pneumatics a gain of 19.1 per cent., as compared with iron, at a speed of 11.5 miles; and on the same grade, with half-dried mud, a loss of 7.5 and a gain of 22, respectively, at a speed of 12.5 miles, the vehicle weighing 1,980 pounds in both cases. On the point of such latter variations, Michelin remarks: "The solid rubber tire is better than the iron tire in certain cases, especially at a trot, when the ground is wet, very irregular or covered with snow; but it becomes inferior to iron when the road is hard and smooth; in any case, it never differs much from

the iron tire, and is always much inferior to the pneumatic. The pneumatic, on the other hand, is superior to the iron tire by one-half." As an average of advantage in traction, the same authority quotes a gain of 18 per cent. in economy of energy, and 5 to 6 per cent. in speed, and by actual tests with weights, suspended on a rope passed through a pulley and attached to a carriage having first, solid, then pneumatic tires, he found a weight of 508.2 pounds required to start with solids, and 437.8 with pneumatics.

Durability of Pneumatic Tires.—In addition to the apparent advantages, in point of absorbing jars, giving better adhesion to the road surface, saving traction effort, and neutralizing the noise and vibration of motors, pneumatic tires, when of sufficient proportions and properly attached to the wheels, are, all advantages considered, also the most durable. That is to say, when calculating the superior speed, comfort and efficiency made possible by pneumatics, we find that their durability is also greater. On this point Michelin says: "Metallic tires are quickly destroyed by the continual hammering to which they are subjected on stone pavements, especially if the wheels carry a heavy load. The metallic tires with which MM. De Dion and Bouton still provide their heavy tractors are very quickly destroyed. In a very short time the tires are flattened and take the form of a trapeze, the large side of which is in contact with the ground." As illustrative of the enormous wear thus entailed, he quotes a noted authority to the effect that the tires of the large transports, formerly used between Paris and Marseilles, lost on an average of 4 grams of metal per kilometer, for every 1,000 kilograms (about one ton) of freight load, giving for the round trip "100 kilograms (220 pounds) of metal left in the ruts of the road." M. Michelin quite properly exclaims: "Colossal figure!" Yet, allowing the utmost exaggeration in faulty calculations or in peculiarly unfavorable road conditions, we can readily credit even this statement on the positive necessity of an elastic support, to "absorb" obstacles, within reasonable limits, rather than offer an unyielding, or unresilient surface for their attrition. Furthermore, we may readily understand that the average of wear, other things being always equal, must be less when the vibrations are

absorbed by an air cushion than when left to affect the material of a solid rubber tire. For ordinary traffic, with moderate weights and speeds, the opinions of other authorities, as quoted above, are competent in evidence for the solid, or semi-solid, tire, but practically all concede the superiority of pneumatics for the uses enumerated in the various tests we have mentioned. It is necessary to note in this connection, however, that, despite the enormous ratio of wear for steel tires on heavy motor vans, they seem to be the only possible support for such use. Pneumatics are out of the question, since they cannot be made of combined size and strength sufficient for heavy vans, unless, as has been

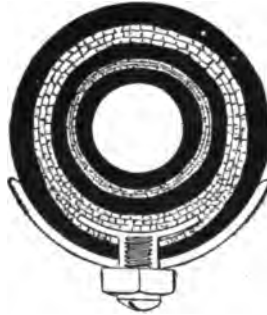

FIG. 99.—The New York B. & P. Single-Tube Tire. The extra thick walls of this tire render puncture less easy, and also provide for a "cushion," or semi-solid, support in case of deflation. The method of attachment by lugs and nuts to a semi-circular channel is one adopted by a large number of other tires, affording a secure hold at the base to safeguard against creeping.

suggested, several of them be mounted, side by side, in parallel channels in the rim, and the solid rubber tires are only a shade more durable.

Analogies for a Buffing Support.—In a certain and very real sense, the yielding tires of a motor vehicle supplement the action of the springs, although not permitting them to be omitted in construction. In the section on springs we have seen that it is essential to correct theory and practice to consider the vehicle and the road it travels as a working unity—as separate, component parts of one machine. In automobile building the principal concern, in this particular, is the vehicle, which must be constructed so as to endure the most unfavorable conditions of

road bed. The effect on the road is quite secondary. In the construction of railroad locomotives, on the other hand, both components of the working unity, the vehicle and the tramway, must be considered: both must be constructed to interact with a minimal wear and damage. In this connection we may quote Matthias N. Forney, a well-known locomotive expert. In speaking of springs, which in locomotives perform some of the functions delegated to flexible tires in automobiles, he says: "A light blow with a hammer on a pane of glass is sufficient to shatter it. If, however, on a pane of glass is laid some elastic substance, such

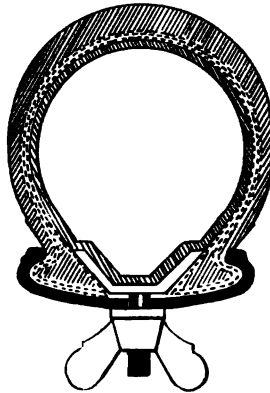

FIG. 100.—The Michelin Clincher Tire. In addition to the lugs and wing nuts which hold the outer tube of this tire to the base, flanges in the length fit into the grooved rim, making the attachment immovable when the tire is inflated.

as india-rubber, and we strike on that, the force of the blow or the weight of the hammer must be considerably increased before producing the above named effect. If the locomotive boiler is put in place of the hammer, the springs in place of the india-rubber, and the rails in place of the glass, the comparison will agree with the case above." Similarly, we may mention the use by printers of a wooden block shod with leather, or any suitable substance, which, placed on a form of type and struck sharply with a hammer, is efficient in producing a perfectly level printing surface. The same block, without the yielding face, would undoubtedly batter the type and injure the printing surface. Inversely, it is true that the striking agent may be worn and

damaged—"the anvil wears the hammers out, you know," as the poet puts it—hence the need of a buffing medium to protect it also. While in automobiles the effect on the road bed is inconsiderable, the light and delicately-gear'd machinery must be protected from damage—the anvil must be shod. Whence it follows that, in the absence of anything like the steel rail surface of a railroad, utility of tires increases directly with their yielding and shape restoring properties. The more readily these functions are exercised, the smaller the wear on all the elements composing the working unity of the machine. Furthermore, the necessity in this particular becomes greater in proportion to the weight and contemplated speed capacity of the vehicle, and, beyond the point where pneumatic tires are practical, must be compensated by more efficient springs and lower rates of travel.

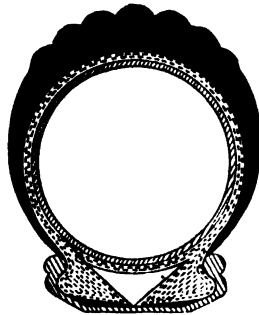

FIG. 101.—The G. & J. Tire. Like the Michelin Tire, this is attached at the base by the fit of the case tube and rim channel, being securely held when the tire is inflated. A flap on the case tube saves the inner tube from pinching at the base.

Structural Points in Pneumatic Tires.—As we have already learned, it is exceedingly desirable that a pneumatic tire should be protected from puncture by thickening the tread, and by some such additional re-enforcement as the insertion of layers of tough fabric. These structural points are embodied in several prominent makes of tire. But even with such devices as these, the tire is not wholly protected from the wear and strain, inevitable in driving under heavy load. Where pneumatics are preferable to solid tires it is because of their superior resiliency, and because of the greater elasticity of the enclosed air. It is evident, however, that these advantages are obtained at the expense of other quali-

ties, since the pneumatic tires, being much more yielding than a solid, even with the greatest compression of the contained air, are immensely more pliable than solids. They are thus liable to be ruptured and rendered useless by an undue tangential pull, or any such conditions as will increase road resistance or promote tearing of the sides or tread. Such conditions must be considered in bicycle construction, but are vastly more important in automobiles.

The situation as regards the use of pneumatic tires in automobiles could be no better summed than in the words of Mr. Beaumont. He says: "Makers have a problem of considerable im-



FIG. 102.—The Dunlop Double-Tube Tire. The attachment is at the base of the inner tube by the endless wires shown, which are pressed against the tubular sides of the rim channel when the tire is inflated, thus affording a positively immovable hold.

portance before them if they are to respond to all the requirements of large pneumatic tires for considerable weights. It is actually on the tread that the obstacle-absorbing or deforming capability is required. Most of the free deformation (under load) must, therefore, take place elsewhere, and this relegates the bending to the thinner sides near the rim and concentrates it there. Only by adopting very high pressures and greater thickness of textile material (at the sides) can this be avoided, and this means hard tires. Except for those users to whom cost is of no importance, this process may go on until the choice between pneu-

matic and solid or 'compound' tires is a narrow one. It will, however, always be in favor of the pneumatic (the one of light construction, as at present largely used) where the extra cost per mile run is not the first consideration."

Construction of Pneumatic Tires — The art of designing and making tires has advanced immensely since the first double tube pneumatics were introduced for bicycle use, about twelve years since. The conditions attending their use on all kinds of roads have been carefully observed and the dangers of rupture and puncture have been reduced by proper constructions in a num-



FIG. 108.—The "Grappler" Tire. Instead of endless wires, this tire carries projecting flanges of metal strips at either side of the base, which press against the inner overlapping sides of the channel rim, affording a secure attachment.

ber of particulars. As we have already learned, such tires may be injured in three ways: (1) They may be punctured through the tread by collision with nails, glass, sharp stones, or other cutting obstacles. (2) They may be ruptured at the sides, or on the tread when the walls are made too thin, by violent contact of any sort, by the torsional strain produced by the motor, or when the brake is suddenly applied. (3) They may be cut or worn at points of jointure to the rims, when sufficient precautions are not taken. Other such sources of disablement, besides steady wear might be enumerated, but these categories include most of the familiar occasions of accident. Accordingly, we find that manufacturers have busied themselves in devising and producing means for protecting pneumatic tires at the points most liable to damage. (1) The tread is made of extra thickness of rubber, and further rein-

forced by enclosed layers of textile material, which is particularly efficient protection when inserted as strips cut bias. (2) The side walls are similarly thickened and reinforced. (3) The points of contact and jointure are protected with thread or woven fabric.

Causes of Puncture.—According to the experience of several tire experts, the devices ordinarily employed to protect the tread of tires are largely useless from the fact that they very often involve other causes of breakage in themselves, thus enabling the verdict that by far the smaller proportion of tire disablements



FIG. 104.—The Goodyear Double-Tube Tire. The attachment of this tire is by the strips of wire, woven like a cotton shoestring, which spread apart under the pressure of inflation, thus securing a rigid hold.

is due to puncture. By reinforcing the tread beyond a certain definite point we contrive to shorten the tire's life on account of the more difficult bending of the walls, occasioning sharp corners and consequent rupture of the fabric. Like several other causes of disablement, puncture may be said to result most often from the use of insufficient diameter in the tires, rather than from walls too thin or yielding. Indeed, it seems to be a well-ascertained fact that, other things being equal, a tire of proportions suited to the vehicle will resist puncture, while one of

smaller diameter will be cut with very much greater ease. The larger sizes of pneumatics, such as the four and five-inch, owe their short-lived usefulness to other causes, yet, Mr. Beaumont, to the contrary notwithstanding, pneumatic tires of four inches diameter are more durable by half than the continuous solid rubber suited to the same size and weight of vehicles, the former representing an average total mileage of 3,000 to the latter's 1,500, as result of a number of tests with heavy high-speed vehicles. In this connection it is well to remark that Mr. Beaumont's statements are accompanied by no figures or reports of tests, which make it probable that they are based on simple



FIG. 105.—The Munger Single-Tube Tire. This view shows the tire deflated, so that the longitudinal rubber buffers come together, thus forming a semi-solid, or cushion tire, and preventing the inconvenient consequences generally following this condition.

calculations gained from experience with vehicles of moderate size in regard to which they may hold good within limitations. The pneumatic tires suited to bear the weight of heavy vehicles are deficient in durability on account of their large proportions—none can be made larger than five-inch diameter—thus no statistics are trustworthy which are based on the behavior of such large pneumatics, as compared with solid tires fitted to smaller vehicles. Solid tires made of size sufficient for the purposes of large racers, unless in some way strengthened lengthwise the tread, as are the indurated fabric tires recently introduced, would quickly tear across and become useless. Heavy vehicles are, therefore, often equipped with sectional solid

rubber tires, as they are called, consisting of a continuous rubber band bearing a number of tooth-like sectional pieces, projecting from the circumference. Some manufacturers of such tires claim a good degree of resiliency for them, alleging this style to be "the only tire which has withstood the tremendous wear and tear of heavy automobile use for a satisfactory length of time."

Constructional Requirements in Single Tube Tires.—In an article contributed to the "Horseless Age," Pardon W. Tillinghast, the inventor of the original single-tube pneumatic tire, writes as follows regarding the structural requirements of single-tube tires for automobiles:

"To accomplish the best results and manufacture a tire that will be practically indestructible, a fabric must be employed in



FIG. 106.—The Ball Tire. In this tire the ill effects of puncture are prevented by the solid rubber balls inserted in the tube, which transform the tire into a cushion, positively proof against flattening.

which there is no starting point of separation between the fabric and rubber, and one that does not have a substantially smooth surface, or a surface that is continuous in the same plane. The attaching surface of the fabric presented for union with the rubber must be greatly in excess of that furnished by the fabrics in use at the present time. A plurality of plies may be used, some of the plies having a more open weave or construction than other plies, and all plies separated by rubber, which will give in effect a single tube or mass of rubber, having fibrous threads extending throughout the mass to prevent bursting, and binding the whole structure into a substantially indestructible body.

"Another means of accomplishing the same end consists essentially of employing a fabric which, when built into a tire, will have the same effect that a bath towel would if it was inclosed

and imbedded in the rubber, with the threads sufficiently strong to withstand the inclosed air pressure, the little loops or fibres extending away from the general plane of the main fabric into the surrounding rubber and being vulcanized therein, furnishing an increased surface for union with the rubber; the general surface line of the fabric in each construction is to be broken so that it is not continuous in the same plane, and there is no starting point of separation between the fabric and rubber."

Two recent patents granted to Tillinghast cover devices for achieving the ends here mentioned. One of these tires is built

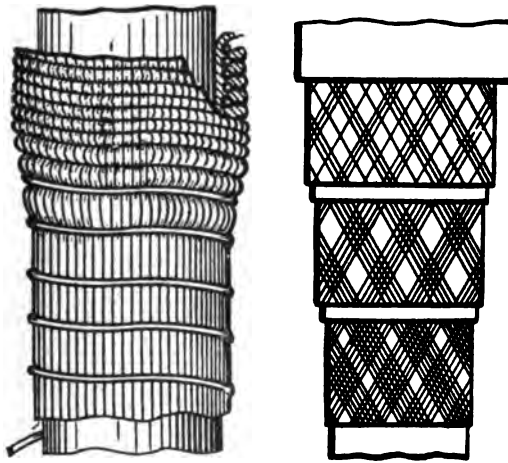

FIG. 107.—The construction of the new types of Tillinghast Single-Tube Tires. The first shows the formation of the fabric into a succession of loops; the second, the open thread fabric tire.

up with a number of strands of thread running longitudinally on the tube and wound spirally with other threads which hold them securely under inflation. The spiral windings are then pushed along the length of the tube, so as to reduce the distance between the windings from one-quarter inch to less than one-eighth inch, with the result that the intermediate sections of the longitudinal threads are pushed up into series of loops, thus forming stronger attachments for the fabric, when held in the material of the rubber wall built up over this layer of threads. Tillinghast's other patent covers a method of strengthening the

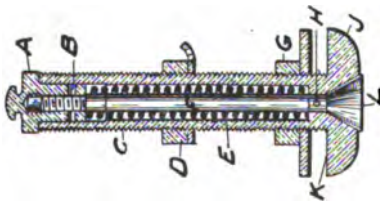

Fig. 108A.

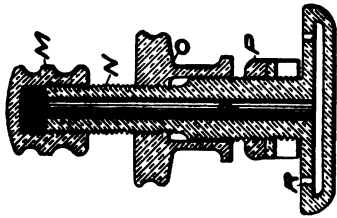

Fig. 108B.

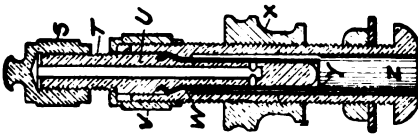

Fig. 108C.

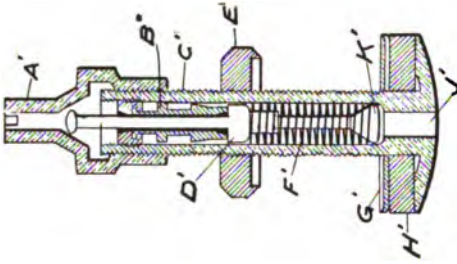

Fig. 108D.

Fig. 108A.—The Sangster Valve. A, removable screw-threaded cover; B, retaining nut, having notches at edge for passage of air; C, the valve tube; D, lock nut and washer for holding stem to the wheel rim; E, helical spring bearing on B and holding valve, L, in its seat; F, valve stem; G, washer holding valve stem to inner surface of rim; H, passages for admitting air into interior of tire; J, head on inner end of valve stem within tire; K, roughened face of J, making joint with the tire walls under air pressure; L, valve seated in J, and carried on the rod, F.

Fig. 108B.—The Welch Valve. This is of the same general description as is used on several double-tube tires. M, the screw cap, closing the valve tube; N, the valve tube; O, cap for gripping the wheel rim, on the inner side of which is the nut and washer, P, which presses the wall of the inner tube against the face of the head, R. When the inner tube is fully inflated the holes shown on the upper face of R are closed by pressure of the rubber walls against them.

Fig. 108C.—The Wood Valve. S, the screw cap on the valve tube; T, end of the valve tube; U, tube for air from pump; V, cap holding detaching valve, W, in the seat, loosed when tire is to be deflated; X, nut for holding valve stem to inside of rim; Y, a rubber tube around pipe, U, admitting air to tire when pressure is sufficient through ports at bottom of tube, U; Z, tube admitting air to interior of tire, also head and washer for attaching to inner tire tube.

Fig. 108D.—The Schrader Valve. A' is the screw cap on the valve tube; B', the valve seat carried on the binding nut within the tube; C', D', the valve; E', nut and washer for securing tire to the inner face of the wheel rim; F', spring holding the valve in its seat; G', H', washers bearing against outer face of wheel rim; J', head holding inner surface of tire tube; K', head at the lower end of the valve stem through grooves at the base of which the air enters the tire.

fabric against any cause that would tend to bursting or tearing the walls, and specifies a series of plies or layers of threads wound on in two diagonal directions, each one being in a more open construction than the last, the closest construction being on the inmost ply of the tire.

Attaching Single-Tube Pneumatic Tires.—The typical method of attaching a pneumatic tire to the wheel is that made familiar in bicycles. Where a wood rim is used the process is, briefly, to thoroughly clean the surfaces of both tire and rim, after which two successive coats of shellac varnish are applied to both and allowed to dry. This varnish is made by dissolving two pounds of gum-shellac in one-half gallon of alcohol. Another method of preparing rubber cements for similar purposes is to dissolve shellac in ammonia. The practice with ordinary shellac varnish is to apply and let dry two successive coats, after which a third coat is given to both tire and rim and the tire is attached, valve first, and secured in position by a good degree of inflation. The varnish is thus able to increase the tire's adhesion to the rim so long as it remains inflated. Thus the inflation of the tire is an essential element to the end of retaining its hold on the rim; for the coating of shellac would speedily tend to lose its grip if the inflation becomes sufficiently imperfect. As the result of insufficient inflation, among other causes, there are two familiar occasions of accident: The tire will "creep," or move longitudinally upon the periphery of the rim; or it will "roll" off the edge sideways.

The Creeping of Tires.—The creeping of a tire is due to the fact that the weight of the vehicle, in process of travel, tends to centralize the pressure on the rubber walls, and cause the tire to bulge just forward of the point of contact with the ground. As may be readily recognized, a continued succession of such bulgings tends both to loosen the adhesion of the tire and the rim, and also to cause the tire to push forward from the ground, and thus around the rim, in the effort to relieve and distribute the pressure. As a result, when inflation is insufficient, great strain and pull will be exerted where the valve is joined to the tire, and a rupture often follows at that point. Even were it possible to

obviate the last-named accident, it is evident that the service of a tire, thus loosened by the creeping process is impaired. Moreover, it would inevitably roll sideways from the rim before it had been long in use. Also, if loose, it chafes at the rim and wears quickly.

Attachments That Prevent Creeping.—It seems to be a well-established conclusion that a single-tube pneumatic is more

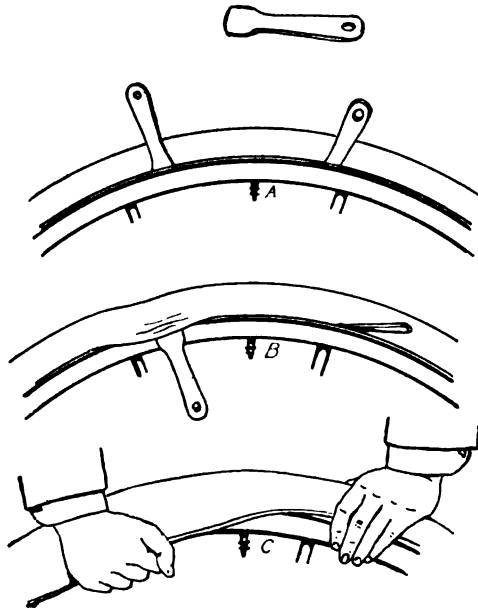

FIG. 109.—Showing the method of removing the case tube of a Dunlop tire. Two tools, like that shown at top of the figure, are inserted between the rim channel wall and the tire, as at A, after deflation. The edge of the tube, being pushed into the central channel, is then raised, as at B. When one wire ring has been raised above the edge of the channel, the case tube is worked off, as shown. (See Fig. 102.)

liable to creep than one of the double tube variety. However, this may be in some measure owing to the fact that the structure of double tube tires more readily permits the use of devices for promoting rigidity at the base, and that the majority of them are equipped with such devices. Perhaps the simplest attachment of the kind is that shown in the figure of the New York Belting and

Packing Co.'s heavy single tube tire. A series of chaplet heads carrying lugs are inserted in the layers of fabric, and these lugs, being passed through holes drilled in the rim, are secured in place by screws and washers. Given strong layers of fabric, as is always essential to the success of this construction, it is evident that the tire will have a very rigid attachment to the rim at the base, by which the evil effects of creeping will be reduced to the lowest point, if the tendency is not practically obviated. It has been widely used with both varieties of pneumatic tires, its success with double tubes having been particularly good in connection with the Michelin clincher and others of similar pattern.

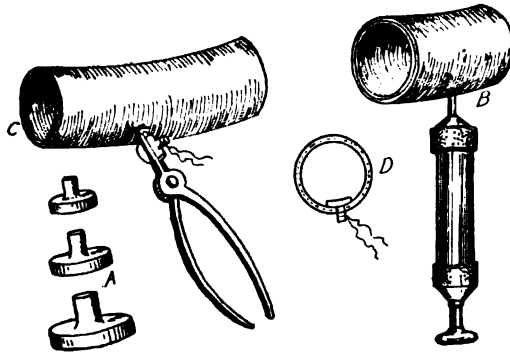

FIG. 110.—Method of repairing a single tube tire. In case of puncture, mushroom patches, as at A, are inserted in the hole, which is usually enlarged with a red hot wire. Liquid cement is then injected, as at B, from a specially prepared syringe, furnished with all repairing outfits. The patch, also cemented, is then inserted, as at C. Its position in the tube is shown at D; where it is pulled into shape by the thread tied to its stem and held by the pressure of inflation. When the tire is inflated hard the patch stem is cut off, and the tube and rim are wrapped about with moist cemented tape, as at D in Fig. 111.

Care and Repair of Pneumatic Tires.—As we have already seen, there are two varieties of pneumatic tire, designated respectively as the “single-tube” and the “double-tube.” The latter was invented and introduced by an Englishman, Dunlop, now so widely known for his work in this field, about 1888; the former, by Pardon W. Tillinghast, of Providence, R. I., about two years later. The immense impetus immediately given to the bicycle industry by the successful production of an inflatable support is historic. Previous to this period some bicycles manufactured by

the Overmans, of Springfield, Mass., had been equipped with a "cushion tire," which was an arch of heavy rubber attached by its feet. It was an improvement in many respects on the solid rubber tires, until then in universal use, but afforded, at best, a very poor imitation of resilient wheel support. Such a tire, of course, required no inflating, and was not injured by simple punctures in its tread. Hence it involved no troublesome processes of repair, whenever disabled. Pneumatics, on the other hand, are entirely disabled by puncture, although, unless of an unusually serious nature, such injuries may be repaired on the road. In

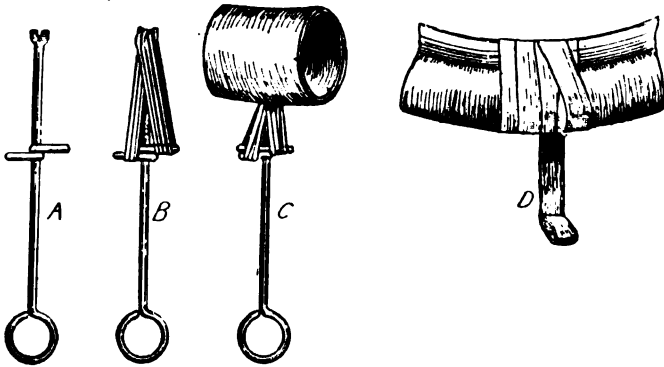

FIG. 111.—Showing method of repairing small punctures. Instead of mushroom patches, ordinary rubber elastic bands are strung on the kind of tool shown at A, as at B. Rubber cement is then injected into the tube of the tire through the puncture, and also smeared on the rubber bands, held as at B. The tool carrying the bands is then inserted in the puncture, as at C; the protruding ends of the rubber bands are pared off, and the tire tube is wrapped with cemented tape, as shown at D.

point of ease of repair, the single tube pneumatic is preferable, and this was one of the considerations which led to its almost universal adoption for bicycles, instead of the double tubes first used. The double tubes, however, possess so many advantages in other directions, some of which we have already learned, that the last-named consideration is quite counterbalanced in the calculations of automobile manufacturers. In both varieties of tire the outer layers of rubber, which are alternated with layers of fabric, are of a quality best calculated to resist wear, and, with the enclosed fabric, present a tough, though elastic, surface to the ground. The air tubes in both are of pure rubber, of practically

no strength, but of the greatest efficiency in retaining air. Thus, when the tire is inflated, the air is retained by the inside rubber tube and prevented from leaking through the interstices in the rubber and fabric layers surrounding it. The single-tube tire differs from the double-tube in the fact that the inner, or air, tube is vulcanized to the outer, or cover, tube; while, in the double-tube variety they are separately attached to the wheel rim, and should not be in contact except under inflation. As may be understood on reflection, a puncture through the tread of a single-tube tire may be readily repaired by the use of mushroom-

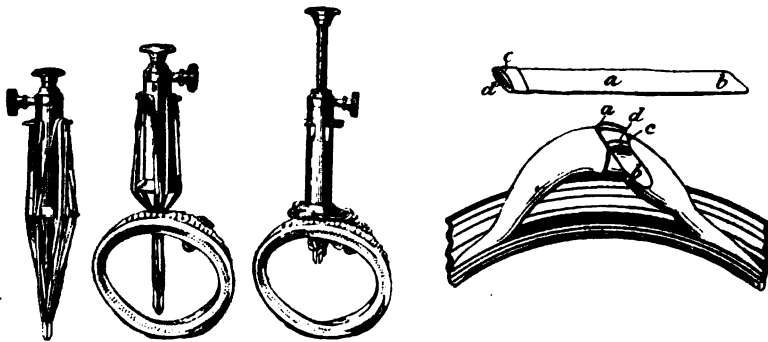

FIG. 112.—The "Kelly" Tire Repairing Tool. This instrument consists of a hollow and slotted awl, made to slide within a cylindrical sleeve having a bell-shaped end. In case of puncture rubber cement may be forced into the tire through the hollow awl. Several rubber bands, generally six, are then attached to the instrument, as shown; one end of each being inserted in the slotted point of the awl, the other ends being hung on the pins projecting at the sides of the sleeve. The needle is then forced in fully, the sleeve being still held away from the surface of the tire. Then the bell-shaped end of the sleeve is set against the tire, enabling the needle to be withdrawn, leaving one end of each band projecting inward through the puncture, the other end being loosened from the pins. The ends of the bands may then be pared off, leaving the surface smooth.

FIG. 112a.—The "Sennevoye" Repairing Strap. In addition to the patches for covering punctures on the inner tube, this strap is buckled around, as shown, to further close and protect the injured point.

shaped rubber patches, which are carefully inserted in the hole and secured in place with cement under the pressure of inflation. With the double-tube tire, on the other hand, the casing tube must be removed from the inner, upon which suitably-sized patches are then cemented, or still more elaborate repairs made, according to the gravity of the accident. In cases of emergency, as when a puncture occurs on the road, the double-tube tire may be repaired in the same manner as the single-tube, thus involving

that the tubes be cemented together, but the repair man can readily cut the adhesion with benzine or gasoline and make the necessary repairs in the proper fashion. With a single tube tire the patch is put on the inside of the air tube, as shown in the figures, being held in place, until the cement sets by the pressure of the contained air. But in case of puncture in an inner tube of a double-tube tire, a patch of cemented rubber or other adhesive is generally attached on the *outside* of the air tube. The adhesion is then maintained, until the cement has set, by the pressure of the air tube against the case tube. In order to afford protection to this patch, rubber bands have been recently introduced which buckle around the injured section and retain the patch under inflation. This operation of patching an inner tube may be performed by the roadside by an experienced hand, when, as frequently happens, necessity so demands.

Proportions of Pneumatic Tires.—Very nearly the most important consideration in point of securing durability and long service in a pneumatic tire is that it should be of dimensions suited to the vehicle it must support. Many accidents and other disablements have arisen from the habit of using tires too small for the load. On the other hand, no particular advantage can come from using tires that are too large. The dimensional limits for practical pneumatic tires are between diameters of $1\frac{1}{2}$ and 5 inches, but the service requirements of most automobile carriages fall far within these figures. As given by a well-known tire-manufacturing firm, the following figures represent about the correct proportions for single-tube tires :

For static load up to 250 pounds, use a tire of $1\frac{3}{4}$ -inch outside diameter.

For static load between 250 and 400 pounds, use tires of 2-inch outside diameter.

For static load between 400 and 600 pounds, use tires of $2\frac{1}{2}$ -inch outside diameter.

For static load between 600 and 1,200 pounds, use tires of 3-inch outside diameter.

For static load between 1,200 and 2,500 pounds, use tires of 4-inch outside diameter.

For static load between 2,500 and 5,000 pounds, use tires of 5-inch outside diameter.

For double-tube tires the same figures apply approximately. The manufacturer of the G. & J. tires gives the following figures:

For a static load of 600 pounds or less, use tires of $2\frac{1}{2}$ -inch diameter on case tube.

For static load of 600 to 900 pounds, use tires of $2\frac{1}{2}$ or 3 inch case tube diameter.

For static load of 900 to 1,200 pounds, use tires of 3-inch case tube diameter.



FIG. 118.—A De Dion Gasoline Quadricycle, for carrying two persons. This vehicle consists of a motor tricycle whose forward wheel has been removed in order to allow attachment to the two-wheeled fore-carriage, as shown.

Although these figures seem to indicate that double-tube tires of somewhat smaller diameter may be safely used, it is quite certain that the estimates are rather general than specific, and that the question of proper tires for each particular vehicle is settled with reference to the extreme wheel diameter and other proportions. For a motor carriage demands not only an elastic support, but also one of sufficient contact surface to enable its resiliency and adhesion to be efficient under load and at good speeds. Thus, while it is desirable to strengthen the rubber and fabric

walls as much as possible against puncture and all undue wear and tear, it is even more important that the cubic content of the air chamber should be of a proportionate size to give commensurately good results.

The Effects of Resiliency in Tires.—A practical test of resiliency may be made by lifting a bicycle or vehicle wheel, bearing an inflated tire, and allowing it to fall a foot or so to the ground. The result will be that the entire structure will rebound a considerable number of times before falling flat, which fact shows how efficient a spring device is interposed between the vehicle and the road surface; also, how great a capacity for absorbing small jars is employed in addition to the springs. If, now, a wheel shod with a solid rubber tire be allowed to fall to the ground in similar fashion, very little, if any, rebound will be observed, which goes to show that the solid tire possesses no capacity whatever for supplementing the springs in the absorption of jars; it throws all of this work upon the springs, which must, in consequence, be exceedingly well calculated, in order to prevent excessive vibration and rocking of the carriage body. This is the reason, as already stated, that it is impossible to attain high speeds on ordinary roads without the use of pneumatic tires. The roads in such cases need to be smoothed in some manner, and, as must be obvious on reflection, this function does not properly belong to the wagon springs and cannot be delegated to them without considerable inconvenience. In a few words, the case of the motor carriage is precisely similar to that of the railroad car, which has the rails of the track to render possible the desired ends of perfect traction and high speed, with the minimum of jar and vibration; it has a ready smoothed road to run on. The motor carriage cannot have such a track, hence must make its own smooth and even traction surface, as it moves along.

Testing Pneumatic Tires.—As seems reasonable on reflection, there is a vast difference in point of resiliency between the various makes and grades of pneumatic tires; also between tires of different sizes, and between single-tube and double-tube tires. Usually the diameter of the tire to be used is calculated with reference to the weight of the vehicle, the idea being that a

given diameter of tube will yield a certain proportionate resilient effect and tractive efficiency. There is, however, a very close connection between the two properties, since a tire whose reactive quality is high is superior for traction to one that is more rigid. This is true because greater compressibility entails a broader surface to bear upon the road, while a greater reactive power in a tire in resuming its proper shape after deformation under load, or from contact with obstacles, requires a smaller traction effort to ensure forward progress. Hence, to determine the serviceability of a tire the question of its resiliency as compared with others is very nearly paramount.

Duryea's Tests for Resiliency.—Very few statistics on this subject have been published up to the present time, and very few

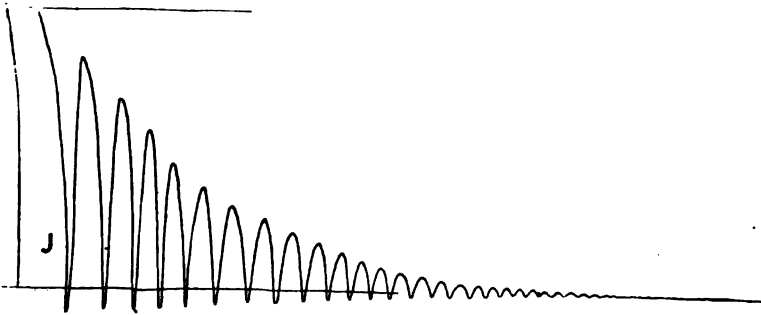

FIG. 114.—Diagram showing test of resiliency of a pneumatic tire, on wheel, dropped to the floor from a measured distance above, and tracing its rebounds by a resiliometer, as described.

systematic experiments for determining this point have been made. Perhaps the most exhaustive investigations were those conducted by C. E. Duryea, some years since, by way of determining the merits of various makes of bicycle pneumatics. In a paper on the subject communicated to the writer and subsequently published in a prominent automobile journal, Mr. Duryea writes as follows:

“In the course of experiments with cycle tires, the writer built a simple resiliometer, believed to be the first in the United States, for the purpose of testing the comparative resilience of the different tires then in use. This device consisted of a bar six or eight

feet long, forming an extension of a wheel axle, the end of the bar being pivoted to the wall at the height of the axle. On this bar a pencil was fixed to bear against a vertical plane surface adapted to slide toward or from the wheel. On this surface paper cards were attached, and the tire to be tested was placed on the wheel. The wheel was then lifted a given distance and supported by a prop. Moving the slide produced on the card a line indicating the height from which the wheel would fall. Tripping the prop and moving the slide at the same time produced a series of zig-zag lines, as shown in the cut, each being lower than the preceding in a practically fixed relation. After the wheel quit bouncing, another line would be drawn showing the normal position of the wheel when resting on the ground. The height of the first

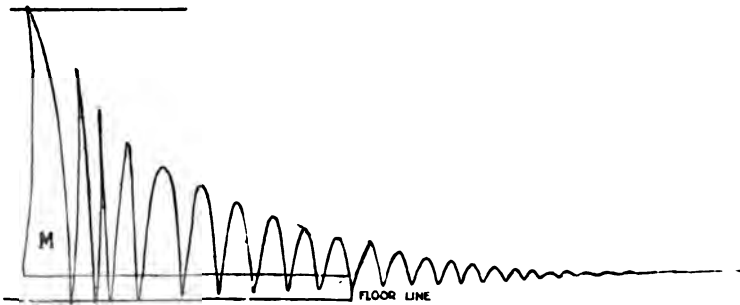

FIG. 115.—Diagram illustrating resiliometer record of a pneumatic tire, on wheel, dropped from a given distance to a one-inch round rod, and recorded as the resiliometer slide is moved.

rebound above the lower line, as compared with the distance between the lines, was taken as the measure of the tire's resiliance for the purpose of comparison with other tires.

"Many hundreds of cards were made, both from smooth surfaces and from obstacles, such as a one-inch rod resting on the floor across the path of the tire. A tire that gave good results from a smooth surface would not necessarily give good results from an obstacle, while the tire that gave good results from a rough surface generally gave good results from a smooth. Tires of equal size and weight, as nearly as possible, were tested at equal air pressures and also at different air pressures. The results of the tests showed that good tires possessed a resiliency of eighty-five to ninety per cent. under favorable circumstances,

while other tires fell as low as fifty-five to sixty per cent. under the most favorable tests that could be given them—clearly a vast difference, and to the writer an unexpected one.

Tests on the Quality of the Fabric.—“The tests further showed that the fabric of the tire should be free to yield in a direction lengthwise of the tire and that the air should be confined by threads encircling the tire transversely, i. e., around its smallest section. These tests were amply borne out in practice by the adoption of thread tires, which are admitted to be much faster than woven fabric or canvas tires.

“The tests further demonstrated that the tire should be held on by some means other than the strength of the fabric, for if the fabric must hold the tire the threads must run more or less lengthwise of the tire, whereas, as already stated, the best results were obtained by placing the threads crosswise of the tire. This same placing of the threads has an advantage in the matter of durability, for it is quite evident that the strength of the fabric will be preserved longer if it is called upon to hold the air only than if doing double duty by holding the tire on the rim as well.

“A third factor, which has an important bearing on light tires, or with heavy loads, is the receptive ability of the tires. If the fabric is free to yield lengthwise the obstacle will push into the tire without damaging the fabric and without lifting the load. With an iron tire, for example, an obstacle like a marble will force the load to be lifted over it, whereas a rubber or pneumatic tire with fabric free to yield lengthwise simply receives the marble without lifting the load. Prints of the positions assumed by the surfaces of different tires were made by placing a lead wire on the obstacle and running the tire over it under load. This outline showed very conclusively that one tire would take its support from the ground, simply swallowing the obstacle, while the other attempted to lift the load just as a solid hard tire would do, in which case the strain on the fabric concentrated at the point of the obstacle must be very great.”

Tests on the Shapes of Rims and Tires.—In addition to the results attained, as above, Mr. Duryea also made cards illustrating the relative merits of single and double tube tires and of rims of various shapes and depths. His conclusions were that :

"The ordinary round tire lying in an arc-shaped rim, as is the common method, cannot utilize its side walls properly when meeting an obstacle, since it is flattened toward the rim and caused to bend at the side abruptly at two places; being bent outward over the edge of the rim and inward at its widest point. The outward bend, together with dirt which may get between tire and rim, tends to chafe the tire on the edge of the rim, a phenomenon commonly known as rim cutting. The other bend cannot stretch the outer layers of fabric, so it must compress the inner fabric and inner rubber, which compression rapidly causes a crack, weakening the tire from the inside, with the result that in a short while the tire begins to swell along the sides and finally bursts. Any rim, therefore, which will hold the tire

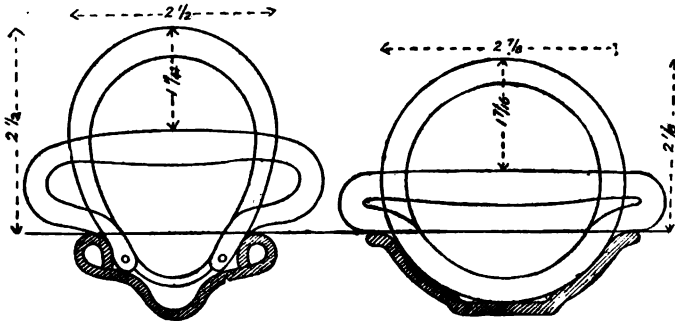

FIG. 116.—Diagram illustrating the relative degree of flattening consequent on deflating a double-tube pneumatic, mechanically secured to base, and a cemented single-tube pneumatic, through one-half diameter above edges of rim. Note the sharp corners of the single tube.

at the bottom only, and yet preserve it from rolling sidewise on the rim, is conducive to long life of tire, for it leaves the side walls free from short bends and increases the depth of the tire, which increases its beneficial results as well."

Relative Efficiencies of Tires.—In order to illustrate his contention, Mr. Duryea prepared figures of a mechanically fastened double-tube tire and of a single-tube cemented tire with arc-shaped rim, showing their shapes when inflated and when deflated to one-half their diameter. His conclusions were that, since a double-tube tire may be compressed further than a single-tube, a small tire of the former variety is as efficient in smoothing the

road as a larger one of the latter variety, while, at the same time, a proportionate deflation of the two shows a further advantage, in that the walls of a double-tube tire are bent much shorter for a given compression than in the single tube, and are forced against the edges of the rim with much less compression, and that, further, the single-tube tire does not flatten out so widely in proportion to its diameter as does the double tube, which latter fact is of importance, because added width means added supporting surface, tending to resist further compression as it increases. He, therefore, concludes that :

“The best automobile tire is the one mechanically fastened so as to relieve the fabric from the strain of holding the tire in position. Its fabric must be as strong as possible, because of the heavy service which means a long fibre closely woven canvas of the greatest possible strength and the fewest necessary thicknesses, which arrangement is less liable to puncture or tear than any thread fabric and is yet as flexible as the necessary strength will permit. Being mechanically fastened, the fabric need not be stretched in the direction of the length of the tire which increases the resilience and lessens the strain and liability of rupture in passing over obstructions.”

As may be readily understood, a further advantage gained by using a double-tube tire, mechanically fastened at the base, is that the sidewise strains encountered in turning corners, are not so liable to cause rolling off the rim. In bicycles this danger is largely averted by the rake, or inclination, taken by the wheels in turning corners, which maintains the entire wheel-structure, including the tire, in one plane. But, in automobiles this rake cannot be obtained except with the front or steer wheels, the result being that the strain brought upon a tire in turning corners at high speed is enormous. A tire, standing high above the rim, and rigidly attached at the base, is capable of a very considerable sidewise deformation without particularly great danger of rupture or other accident. Howbeit, if the inflation be insufficient, such side strains are very liable to loosen the fastenings, particularly when clamps are used.

Attachments for Double-Tube Tires.—The G. & J. tire has several points of resemblance to the Michelin clincher. The outer, or casing, tube carries longitudinal flanges, intended, as is

shown, to fit into the grooves on the rim. The method of attachment is, briefly, to insert the flange on the side carrying the rubber and fabric flap piece, shown beneath the inner tube; then to set the inner tube in place, valve first; finally, to insert the flange on the side of the outer tube still unattached beneath the opposite groove on the rim, and beneath the flap piece already mentioned. The side last attached is first disengaged in the act of removing the tire from the rim. By inserting the flanges of the outer tube in the grooves of the rim a very firm grip is obtained, which cannot be disturbed without the use of a special tool



FIG. 117.—“ Automotor ” Gasoline Phaeton, with rumble seat, illustrating a recent design in light motor carriage construction.

furnished with each set of these tires. Moreover, this secure attachment at the base of the tube neutralizes the tendency to creep, which effect is greatly increased by perfect inflation. The secure attachment, obtained by the flanges, is augmented in the Michelin tires by the use of such lugs and screws as are shown in connection with the type of tire described above. The danger of puncture is largely overcome in this tire by thickening and corrugating the tread, but should puncture ever occur, it is possible to readily detach the outer tube from the wheel rim, in order to apply the necessary cement and patches to the inner.

The Dunlop Double-Tube Tire.— With the Dunlop double-tube carriage tire the process of attaching is somewhat similar, although the flanges are here replaced by one or several endless wire rings, inserted in the fabric of the outer tube, and of such length as to fit the rim tightly at the base of the tubular retaining flanges or edges, as shown, when the inner tube is inflated. The process of attachment of the outer tube is, briefly, to insert the wire edge of one side of the outer tube in the bottom of the deep central channel of the rim, which, as may be readily understood, permits the ring to be forced over the tubular edges with very slight effort. The inner tube is then put into place, valve first, after which the other wire ring is inserted in the bottom of the central channel and similarly urged over the edges of the rim. By inflating the inner tube, the wire rings are forced against the bases of the tubular edges; all tendency to roll or pull off under this outward stress being thus overcome. A very firm and rigid attachment is also made at the base, completely around the rim, with the result that creeping is rendered impossible. The tubular retaining edges obviate rim-cutting, as the tire is forced against them, under the weight of the carriage. The layer of fabric at the base of the inner tube eliminates all tendency to pinching or wearing of the rubber against the corners of the case tube, which was a constant source of anxiety in some of the earlier patterns of this tire made without such protection. Some Dunlop tires, intended for heavier service, have an additional, detachable tread-piece, which may be readily replaced by proper appliances when worn, thus ensuring a much longer life to the tire and acting as an additional precaution against puncture.

The Goodyear Tire.—The theory of producing firm attachment between tire and rim by the use of endless wire rings, or bands, is also applied in the Goodyear vehicle tire, as is shown in an accompanying figure. The walls and tread of this tire are composed of the usual layers of fabric and rubber, which are continued also into the square portion intended to fit the rim. At either side of the base, and so disposed as to bear against the outwardly flanged edges of the rim channel, are ribbons of wire inserted in the fabric of the tire wall. The wires of these ribbons are braided together, like the threads of a cotton shoe string or a

binding tape, so as to shorten in length under any impulse to spread the strands apart. The braiding, being thus spread by the inflation of the tire, contracts in length so as to grip the rim very firmly, and prevents all creeping or other movement tending to cut either the wire or the fabric. The arrangement permits the use of a shallower rim than is possible with most other pneumatic tires.

A Non-Collapsible Tire.—The Munger single tube tire, as shown in Fig. 105, bears on its upper and lower walls longitudinal rubber buffers, so shaped as to fit together in case the tire be-

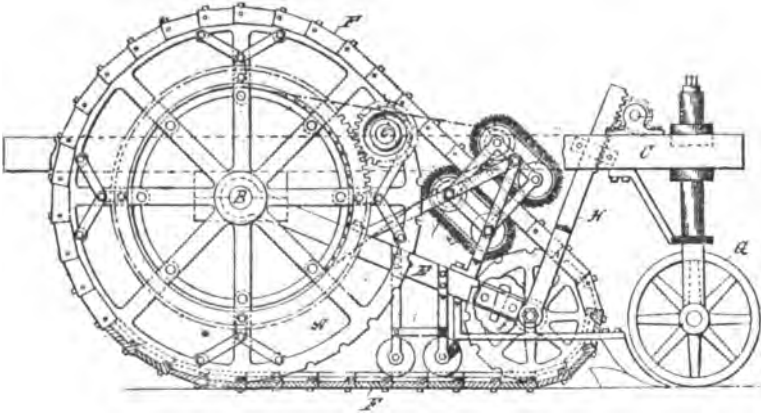

FIG. 118.—Wheels and running gear of a "track-laying" tractor, designed to travel on ordinary roads with a small amount of surface friction without the use of pneumatic tires.

comes deflated from any cause. In this contingency it is not necessary that the wheel should run on its rim, to its obvious destruction, since these buffers prevent complete collapse and to a large extent give the effect of a solid tire. The tread buffer also renders puncture from sharp obstacles an exceedingly remote possibility. It further presents a greater surface than does the ordinary round-faced tire for the displacement of air, and, as a result, can be used with less inflation with consequently better resiliency and power to absorb vibration. One disadvantage, however, lies in the lips overhanging the edges of the rims, which would seem to prevent the sides from bending as freely as desirable.

Tractive Devices: Track-Laying Wheels.—In order to attain the end of superior traction, otherwise than by the use of pneumatic tires, several inventors have devised and patented road locomotives that lay a track as they advance. This is accomplished by the use of a suitably constructed chain belt passing around the wheels of the vehicle and driving them from a sprocket directly geared, or on a countershaft. One of the best designed of these is shown in an accompanying figure. It would undoubtedly serve the ends of ready traction and power economy, but has never been tested under high speed conditions. Generally speaking, it seems hardly suitable for motor carriage purposes, and is mentioned only to show that the necessity met by pneumatic tires has been repeatedly apprehended by vehicle designers.

A Double Interacting Elastic Wheel.—Another device of more recent invention and even greater excellence of design deserves mention in this connection. It is, in short, a wheel contrived to combine the durability and good tractive properties of a solid tire with the resiliency of a pneumatic, while quite effectually protecting the latter from puncture and other wearing strains of travel. These ends are achieved with a very ingenious mechanism, by which two wheels are hung on one hub or axle boss, as shown in the accompanying diagram, the outer one being shod with an ordinary solid tire, the inner with a pneumatic. Of course, in order that the desired effect should be perfectly achieved, it is necessary that there should be some play between the two wheels, permitting the weight of the vehicle to bear against the lowest point of the pneumatic tire on the inner wheel, without involving distortion of any part of the structure. Accordingly, the hub is constructed in sections, between which considerable movement is possible. These sections, as constructed for several types of these wheels, are shown in accompanying sketches, and are, briefly: A central hub plate—or spoke hanger where wire spokes are used—which is perforated to fit loosely over the axle boss, and has also a slot cut on two opposite radii from the nave; two other hub plates, or “half hubs,” similarly perforated and interiorly slotted, and also arranged for attaching spokes; two “intermediate floating guide plates,” with keys set upon reverse sides at right angles to each other, which guide

plates, being set between each of the outer hub plates and the central hub, have their keys or splines inserted in the grooves above mentioned, thus permitting a complete rotative movement between the central hub and the outer hub plates, which gives the desired play between the former and the two latter.

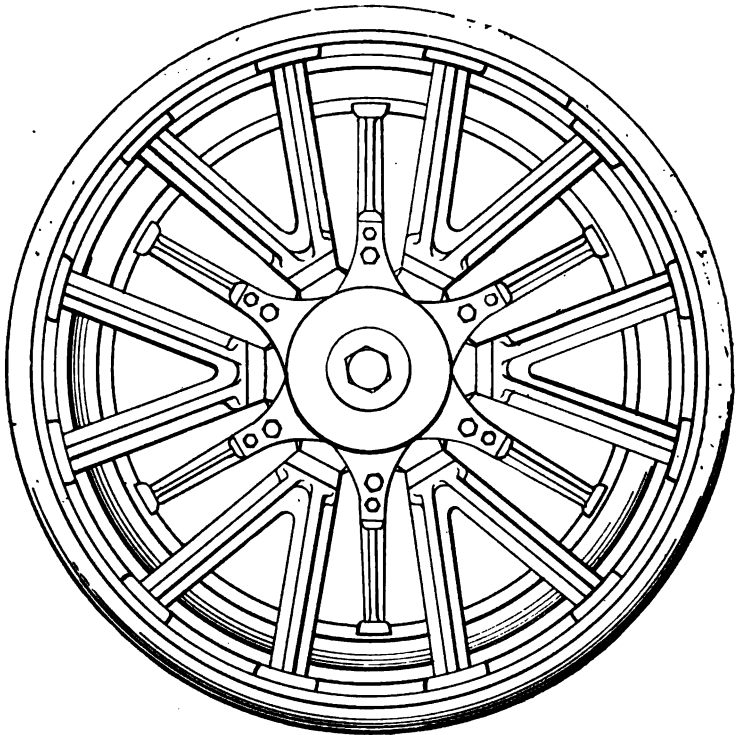

FIG. 119.—The Double Interacting Wheel, constructed for heavy carriage use. As may be seen, it consists of two distinct wheels hung on one axle and in the same plane. The larger has a solid rubber tire for the sake of good traction, the smaller has a pneumatic for the needed resilient effect.

Construction of the Double Interacting Wheel.—The central hub supports the spokes of the outer, or larger, wheel, which is shod with the solid rubber tire, and the outer hub plates attach similarly from either side to the inner, or smaller, wheel, which is shod with the pneumatic. Since the hub of this inner, or smaller, wheel fits snugly over the axle boss, the outer one hav-

ing considerable play around it, it follows that the effect of the load is to bring the weight upon the pneumatic tire, which bears against a circular channel, thus delivering the benefit of its resiliency to nearly one-half the wheel diameter, rather than to only one point at the ground. Thus, while a free movement radially is permitted by the interaction of the wheels, they are so locked, by the keys or splines on the floating guide plates of the hub, that they are compelled to rotate together. A wheel thus constructed may be tested in the manner above specified, and will show the effect of the pneumatic tire's resiliency, as much, if not more, than if the tire were mounted on the outer rim in

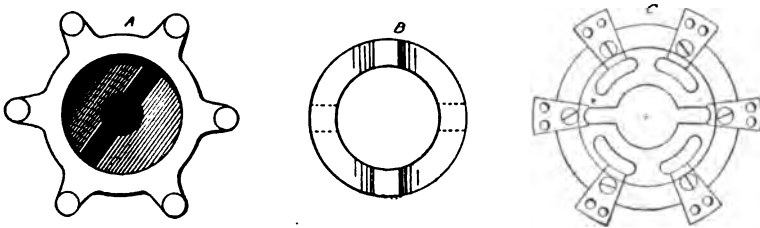
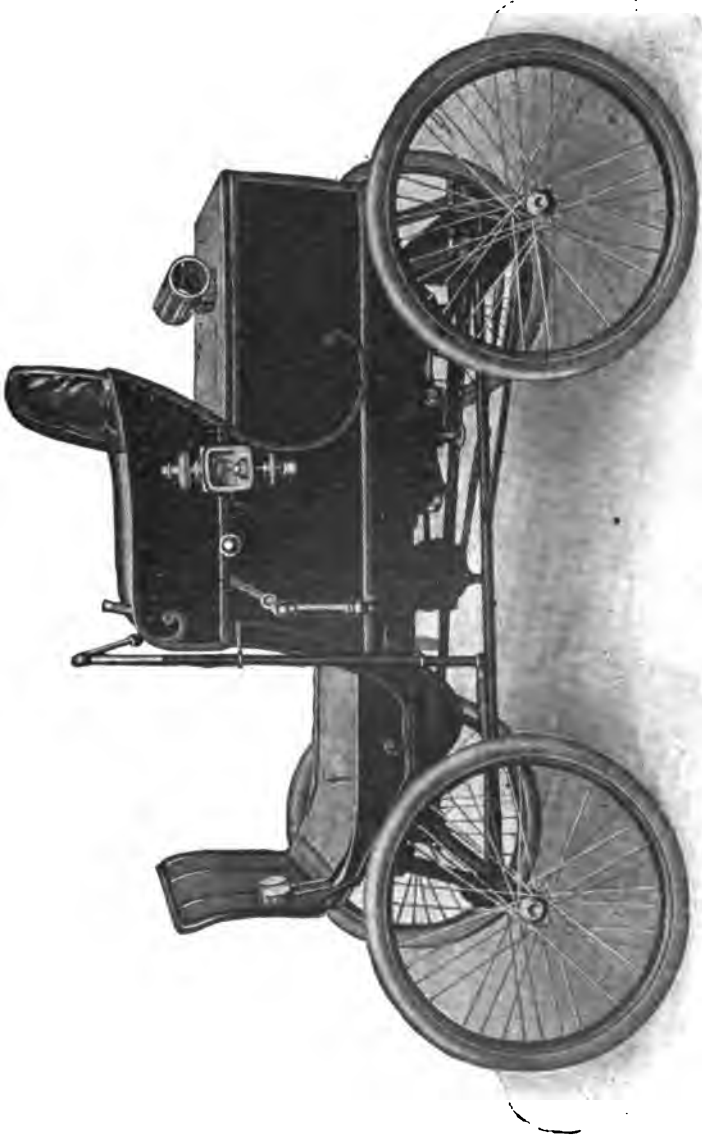

FIG. 130.—Elements of the Compound Hub of the Double Interacting Wheel. A is the outer hub plate, showing interior slot. B is one of the two floating guide plates, carrying keys or splines, arranged on either side, as indicated. C is the central hub plate, also slotted, and arranged for hanging spokes.

contact with the ground. At the same time the tire is perfectly protected from puncture; is not liable to creep, since the strain of the load, delivered at the point of contact on the outer rim, is transmitted through a V-shaped area to the interior of the wheel, thus involving that the pneumatic tire be bound by a considerable arc of its outside containing channel. Such a construction and operation also prevent destruction of the pneumatic from other causes, such as wrenching and kneading on the rim, that result in tearing and overheating. This means that a cheaper pneumatic tube may be used than would be possible against the ground under heavy load.



A Typical American Steam Carriage : The "Reading" Runabout.

CHAPTER TEN.

THE THEORY, CONSTRUCTION, AND OPERATION OF STEAM BOILERS.

Principles of the Steam Engine.—While it may seem hardly necessary to treat of the theory and construction of the steam engine, even in a book intended for non-technical readers, a brief review of main points cannot fail to make clearer what is to follow. As is well understood, the steam engine depends for its operation on the expansive power of water vapor under the influence of heat. When water passes from the liquid into the gaseous state its tendency to expand is immense, and any attempt to resist or confine the process is the occasion for producing a force of almost unlimited possibilities. Thus, when water is heated above 212 degrees in a confined receptacle, known as a boiler, there is generated a pressure sufficient to move machinery. Being let out through valves operated by properly adjusted gears, it may be controlled so that, by its expansive force, it drives backward and forward the piston sliding in a hollow cylinder; thence by piston rod, cranks and wheels, imparting its energy for the accomplishment of work.

Conditions of Steam Generation.—There are certain conditions which must be observed in the construction of steam engine boilers, in order to ensure the heating of the entire volume of water contained in as short a time as possible. These conditions refer to the properties of water as a conductor of heat. In the first place, in water as in air, the tendency is for the heated portions to rise; thus if the heat is applied at the top of an enclosed body of water the first few inches may be near the boiling point, while the layers below will be nearly, if not entirely, as cold as before heat was applied. If, however, the heat be applied at the bottom of a boiler a circulation will immediately be established, the heated layers from below constantly tending to rise, and the unheated above constantly tending to sink to the bottom. Some shell boilers—that is to say, boilers consisting of a water space

pierced by heating flues—have specially arranged screens to control the circulation of the water under the influence of heat. Such an arrangement is advantageous in separating the various layers of water and hastening the process of steaming by preventing the undue giving-off of heat. Many water-tube boilers, consisting of coils or trains of tubes containing water, accomplish the same end by constructing the tubular system in the general directions of water circulation in relation to the steam drum, thus securing rapid and evenly distributed steam generation.

Power Capacity of Steam Boilers.—In order to obtain good results from a steam engine, it is obvious that all parts must be in proportion. That is to say, the boiler must be capable of generating sufficient steam to drive the cylinders and enable the machinery to be moved accordingly. Now, the power of boiler and engine may be calculated by simple rules of proportion, which, when followed in the work of construction, permit economy of space and material. Of course, it is obvious that a boiler of large generating capacity will develop less power with a poor engine, one using steam wastefully or being otherwise faulty, than with an engine of better design. With the former it might be able to develop only sixty horse power, with the latter 100 horse power, but this does not mean that a boiler built for an ultimate capacity of sixty horse power can drive to its full strength an engine of 100 horse power. It cannot generate sufficient steam, nor with sufficient rapidity. It follows, therefore, that there must be a standard for measuring the generative power of a boiler, which is different from that applied in calculating for the engine. The standard horse power at the boiler—the power required to raise 33,000 pounds through one foot in each minute—is, accordingly, the evaporation of thirty pounds of water per hour, fed to the boiler at a temperature of 100 degrees, Fahrenheit, and giving a pressure of seventy pounds, as indicated by the steam gauge. Hence, it follows that tests for boilers are based upon their capacity for evaporating so many pounds of water per hour, under the conditions specified.

But the amount and rapidity of the evaporation depends upon the quantity of heat applied to the water in the boiler for each cubic inch of its contents. Hence it is that the power of a boiler

to evaporate so many pounds of water per hour at a given pressure in the gauge may be calculated directly from its heating surface as compared to its cubic content. The greater the heating surface, the greater the capacity for generating given horse power; and the smaller the heating surface, as compared with the contained volume of water, the smaller this capacity. In accordance with this principle, boilers are constructed with tubes

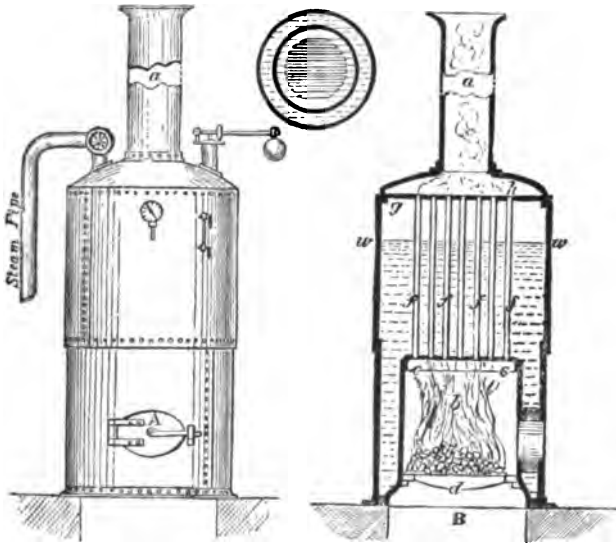

FIGS. 121, 122 and 123.—Exterior and sectional elevation of an upright stationary boiler, also plan, showing the grate bars and the surrounding waterleg. In these figures, A is the fuel feed door; a is the chimney; f, f, f, the flues; w, w, the water level; c, c, the lower tube plate; g, the upper tube plate. The feed water is heated in the waterleg around the fire box.

or flues running in their length from head to head, in order that the heat from the furnace may be *directly* applied to as many cubic inches of water as possible, as the smoke and gases of combustion pass through, under draught, on the way to the chimney. The number and size of these flues, therefore, constitutes the standard for a boiler's capacity in proportion to the length and diameter of its shell.

Rule for Computing Boiler Capacity.—The rule usually applied in calculating the steaming capacity of a shell boiler is to find the total number of square feet of heating surface, and divide by fifteen. This gives the nominal horse power capacity, since, as has been calculated, a boiler can generate one horse power in steam on each fifteen square feet of the heating surface. In horizontal stationary boilers a portion of the shell—generally two-thirds—is counted as heating surface, being directly exposed to the fire, but in computing for most of the boilers used on Ameri-

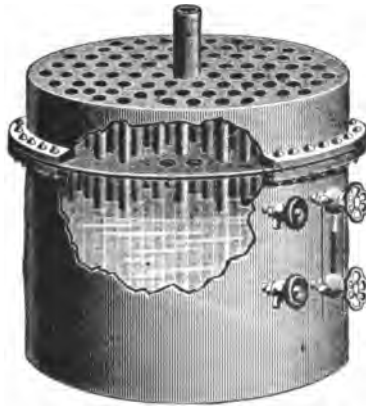

FIG. 124.—The Kitts-Tonkin Dry-Plate Boiler, for steam carriages. This boiler consists of two seamless steel pressings riveted together through a flange, as shown. The flues are inserted through perforations in the upper and lower crown sheets, and in the intermediate dry plate, also secured by the rivets. Sufficient space is left around the flues to allow the steam to collect above the plate, going thence to the engine. The dry plate forms a very efficient separator. The steam connection to the engine is by the vertical tube at the centre of the upper tube plate. It extends only a short distance into the space above the dry plate, thus ensuring the feeding of perfectly dry steam.

can steam automobiles, the total area outside of the flues is so insignificant that it need not be included in general calculations on the boiler horse power.

The quick steaming power, due to increasing the heating surface in proportion to the water-content of the boiler, realized in modern boilers, particularly in some of the small ones used on steam carriages, has brought the average very much below fifteen square feet per horse power. Some water-tube boilers have one horse-power for each five square feet.

Rapid Generation of Steam.—As we have seen, a boiler adapted to the needs of a steam road carriage must combine lightness, compactness, strength and power-generating capacity. It must also be capable of rapid generation. That is to say, it must be so constructed that it will have the steam up within a reasonably short time after the fire is started. Were it not possible to do this there would be vexatious delays at the beginning

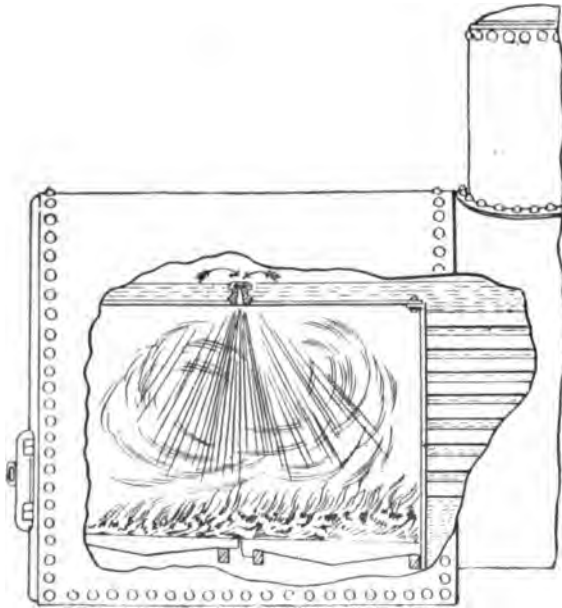

FIG. 125.—Part section through a large horizontal stationary boiler, showing the fire box and flue space. A fusible plug set at the highest fire line is melting, thus allowing the water and steam to escape into the fire box, extinguishing the fire. Fusible plugs will not melt so long as the water level is at the right height.

and also considerable waste in fuel and water, through the necessity of keeping the heater at work during stops, long or short. All such faults would greatly embarrass its usefulness in the hands of persons not skilled engineers. As a matter of fact, however, the result of rapid generation may be achieved in any boiler combining a large heating surface with compactness of construction, and by observing these simple conditions most

American steam automobiles are highly efficient in this respect. Another result which seems to follow in boilers constructed for rapid generation—having a large heating surface in comparison with its cubic water-content—is that a horse power may be developed very greatly in excess of that allowed by the formula above quoted. This, as we shall see, is particularly true of water tube boilers.

There are several methods of increasing the heating surface of a boiler, any one of which will prove efficient within certain limits. In general, it seems a good rule that the cubic capacity of

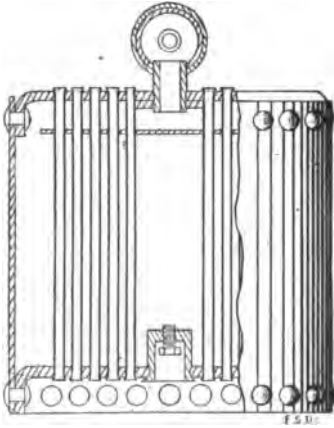

FIG. 126.

FIG. 126.—Section of a type of carriage boiler, showing the disposition of one row of tubes, also location of fusible plug, steam separator and baffle plate. The shell is a seamless steel tube and the tube plates are inflanged and riveted.



FIG. 127.

FIG. 127.—Convenient form of fusible plug contained in a screw bolt for insertion in crown-sheet, as in Fig. 126.

the water chamber may be decreased, in order that the heating surface may be proportionately increased. This result may be achieved by inserting a larger number of flues, as in the boilers of most American carriages. Water-tube boilers also accomplish the same result by the excellent device of feeding water into a coil or a train of pipes which are directly exposed to the heater. Particularly when the pipes are joined to a separate steam chamber, this type of boiler has been found very efficient for vehicle work, and is largely used on heavy steam wagons.

Manner of Securing Boiler Flues.—The flues of boilers are secured to the tube plates as shown in the accompanying figure. Both plates are bored with the required number of holes of a size suited to fit the flues exactly. The flues, when inserted in the holes, are expanded by the use of a mandrel, and the protruding ends are then flanged over upon the plates. In locomotive boilers and in some others of large power extra security is attained by driving a slightly tapering ferrule into the tube at the outer end, leaving a small portion protruding, so that, should a leak be sprung at the end, the joint may be tightened by driving it home. Such ferrules are usually omitted in the construction of automobile boilers, the moderate pressure at which they are

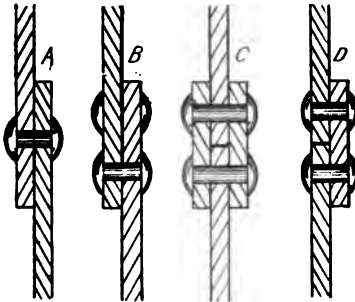

FIG. 128.

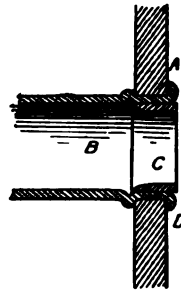

FIG. 129.

FIG. 128.—Four methods of joining the shell plates of a steam boiler: A, single-riveted lap joint; B, "zig-zag" riveted lap joint; C, double butt-strap joint; D, single butt-strap joint.

FIG. 129.—Method of expanding the ends of flues into the crown plate of a boiler. A is the crown plate; B, the flue tube; D, where the end of the flue is flanged over; C, a ferrule for giving extra tightness, as sometimes used.

worked being scarcely sufficient to break a well-made joint of the kind described. Moreover, as the co-efficient of expansion for copper, of which the flues of small boilers are usually made, is greater than that for steel or iron, which composes the rest of the boiler, the flues expand first, thus adding another element of security to the joint.

Also, since, at very high temperatures, copper begins to expand less rapidly than iron or steel, the result is likely to be a leak at the flue joints, which prevents more disastrous consequences. Any serious leaks from this cause may be readily repaired by a tube expander, when the boiler is cooled. Thus copper flues furnish a factor of safety.

Shell and Water Tube Boilers.—Both varieties of boiler are used in automobile construction, although in most of the best known makes of American steam carriage the small shell with a large number of flues seems to be the favorite. Numerous engineering authorities, however, claim that the water tube variety is better adapted to light road carriages, intended for the use of amateur engine drivers, from the fact that, as they are less liable to explode with disastrous consequences, there is no temptation to allow the water level to rise unduly and thus cause "priming," or the delivery of hot water into the cylinders. With the best shell boilers there is danger of explosion if the water is allowed to sink below a certain level, or incrustations on the base plate decrease the conducting properties of the metal. Either condition is liable to cause overheating. Thus fuse plugs are inserted



FIG. 130.—The Dudgeon Boiler Flue Expander, as used for making expanded joints on the flues of large boilers.

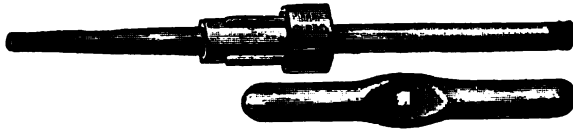

FIG. 131.—An Expander for the tubes of carriage boilers. By the use of this tool damage to the boiler may be readily repaired.

at some convenient place, so as to melt when the metal of the shell becomes unusually heated and allow the remnant of water to extinguish the fire. Such fusible plugs are usually made of same alloy of tin and bismuth, and melt at various temperatures up to 400 degrees, Fahrenheit.

The Blow - Off Cock.—This is an important attachment of all boilers, furnishing a ready means of removing the water from the boiler under pressure of its own steam, which is called "blowing-off." It is also used in some carriages for attaching a hose to fill the boiler at starting, or for injecting water for cleaning the interior. It is usually closed with a box nut for receiving a wrench, but sometimes by a cock, as in large boilers.

CHAPTER ELEVEN.

THE TESTING AND REGULATING ATTACHMENTS OF STEAM BOILERS.

Boiler Attachments: Try-Cocks and Water Glass.—In operating a boiler of any design it is essential both for safety and efficiency that the engineer should be kept constantly informed on the level of the water and the pressure of the steam. For this reason boilers are fitted with try-cocks, water glass and steam gauge, all of which are depicted in accompanying figures. There are usually three try-cocks, as shown, the upper one intended for steam, the second at the working level of the water, and the third at a fixed point above the fire line. In conditions of uncertainty in the action of the water glass the engineer may find out whether the water level is too low by opening the lower cock, or may find if it is too high by opening the two upper ones. In making test it is necessary to leave the cock open sufficiently long to discover whether all steam, all water, or a mixture of both is escaping. In large boilers it is desirable thus to open the try-cocks several times a day.

The water glass, or water column, furnishes a ready means for determining the exact height of the water in the boiler. It consists of two cocks opening into collars arranged to be connected by a length of glass tubing, as shown in the figure. By opening these cocks the height of the water may be seen in the glass tube. Since it is such an important consideration in boiler operation that the water level should be constantly watched, it is necessary that the water column should be placed where the engineer may constantly observe it. Thus it is that, in steam carriages it is disposed in the side of the body beneath the seat, its condition being readily observable by the driver by reflection in a small mirror set to one side of the dashboard. Lamps are also arranged behind it, so that the level of the water may be observed at night.

The water glass also gives information on the condition of the water within the boiler, as when oil or scum has collected on the surface, causing foaming. Then the uneven fluctuations in the

water level indicate the condition beyond doubt. When this condition is noted it is time to blow off the boiler, or, at least, to observe carefully its operation.

Troubles with the Water Glass.—Troubles with the water glass that must be constantly guarded against are stoppage by sediment and the breaking of the glass tube. The former diffi-

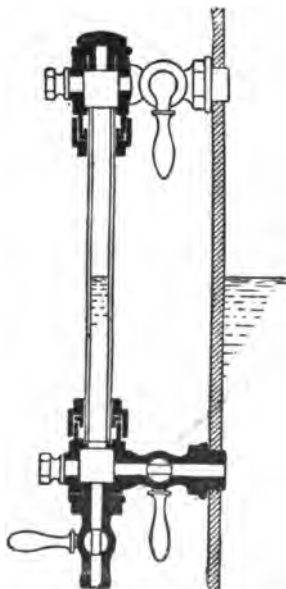

FIG. 132.

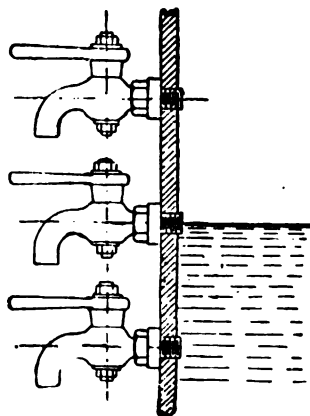

FIG. 133.

FIG. 132.—Sectional view of a water glass, as used on large boilers, showing water level and sections of stop-cocks, drain-cock, tube packing and retaining nuts.

FIG. 133.—Section on boiler shell showing the designed position of the try-cocks: the center one coming at about the average water level.

culty may generally be remedied by closing the lower cock and allowing the steam from the upper one to blow through the drain cock shown at the bottom. In case the glass tube be broken it is necessary only to close both cocks, and insert a new tube in the collars, having first removed the nuts and packings at top and bottom. In order to obviate, as far as possible, breakage of the glass it is necessary to avoid too sudden changes of tem-

perature in the column, when first opening the cocks, after getting up steam.

Most of the water glasses used on steam carriage boilers have self-closing valves, which operate to prevent the escape of steam in case the glass is broken. In the use of these valves particular care is needed, since they are very liable to be clogged with sediment or incrustation, causing false indications of the water level and enabling the boiler to be burned out before the driver knows that anything is wrong. Several carriage owners, in the writer's experience, have had these valves removed, and contented themselves with closing the cocks every time the glass is broken. This

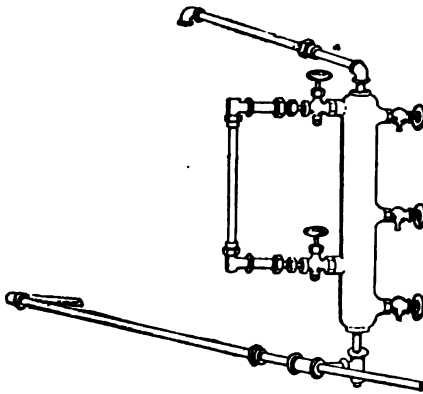

FIG. 134.

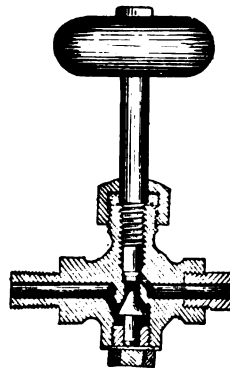

FIG. 135.

FIG. 134.—Water column, try-cocks and water glass of the "Locomobile" Carriage. The water column is connected to the boiler at top and bottom, as shown. The continuation of the lower pipe to the right leads to the steam gauge.

FIG. 135.—Type of check valve for a water glass. As may be seen, the cone-shaped valve remains in the position shown, so long as the pressure is the same at both sides. When the water glass is broken, the steam, coming through the pipe at the left, causes the valve to rise into its seat, thus closing the opening.

may be a rather exceptional experience, but it is extremely desirable, if not imperative, to verify the water glass reading by the try-cocks before starting the carriage.

The water glass is an important piece of mechanism, and cannot be too closely observed and cared for. Skilled engine drivers take its record constantly, and so very important is it that no error regarding the water level should be made that some inventors have proposed using colored floats to attract the driver's

eye, and enable readier reading of the record. A supply of glass tubes should always be kept on hand in a steam carriage so that breakage may be immediately repaired. Also, every possible precaution should be adopted to prevent the accumulation of sediment that might obstruct the free passage of the water into the glass. It is well to clear the tube by flushing with steam at frequent periods.

Low Water Alarm Devices.—In order to provide against the neglect and mismanagement frequently to be encountered in driv-



FIG. 136.

FIG. 136.—The "Reliance" Low-Water Alarm.



FIG. 137.

FIG. 137.—The "Kitts" Low-Water Alarm.

ing steam carriages, the water glass has been supplemented by a further form of attachment, known as a low water alarm. There are several good varieties of this contrivance on the market, all of which are constructed so that when the water from the boiler, admitted by cocks and tubes to the body of the instrument, has fallen below the desired level a valve will be opened and steam admitted to a whistle. The sound of the whistle warns the driver that the boiler feed is in some way out of order.

The "Reliance" low water alarm, shown in section in an accompanying cut, consists of a cylindrical steel chamber, in which a hollow metal spheroid depends from the end of a lever. The fulcrum of this lever is at the opposite end, and immediately

above it is a lug which operates a needle valve, as shown. So long as the water in the boiler and the gauge column is at the proper height the ball, or spheroid, floats, thus holding the lever up, and keeping the needle valve closed. When the water level falls, the float falls with it, depressing the lever and opening the valve, with the result that steam is admitted to the whistle. Such a device is perfectly reliable, unless the float be broken or punctured, as seldom happens, since both it and the cylinder containing it are constructed to withstand higher pressures than are ordinarily used in the boilers of steam carriages.

The Kitts low water alarm is of somewhat different construction; using a solid weight of phosphor bronze, to which are attached compound levers to open the whistle valve, when the water level falls too far. The theory is that the solid weight is lighter in water than in air, and that so long as the water stands at the required height around it, the up-buoying effort will suffice to keep the whistle valve closed. So soon, however, as the water level has sunk unduly the weight will drop with it, thus causing the levers to operate to the extent of opening the valve to admit steam to the alarm whistle. The efficiency of the large weight in keeping the valve normally closed is furthered by another smaller weight on the second lever, as shown, bearing direct on the valve. The advantage of this construction, which is eminently practical, is that the troubles often encountered with hollow floats, and, perhaps, feared oftener than encountered, are entirely escaped.

The Steam Gauge.—Not only as a factor of safety, but also as a means of determining the power output, a steam gauge is attached to all well-appointed boilers. This is a device which indicates on a dial the degree of pressure generated by evaporation of water within the boiler. The steam gauges in common use are the same in outward appearance, although all are constructed with one of the two varieties of internal mechanism, geared to move the hand under steam pressure. In the first variety the steam bears upon a diaphragm, regulated to yield in proportion to the pressure exerted, and actuate the dial mechanism accordingly. The second variety of steam gauge operates through the tendency of a flattened and bent metal tube to straighten out under pressure of the steam or gas within it.

Such a gauge is shown in an accompanying figure, which shows a tube, flattened to an ellipsoidal cross section, connected by one end to a steam pipe leading direct from the boiler. When the cock is opened, steam is admitted to the tube, its pressure tending to change the flat section to one more nearly round, and in the process causing the tube to tend toward uncoiling itself. This tendency toward uncoiling is in the direction of a straight line conformation, and hence the other end of the tube, attached, as shown, to a link which connects it to a lever bearing a toothed segment, tends to move to the left (as in the cut),

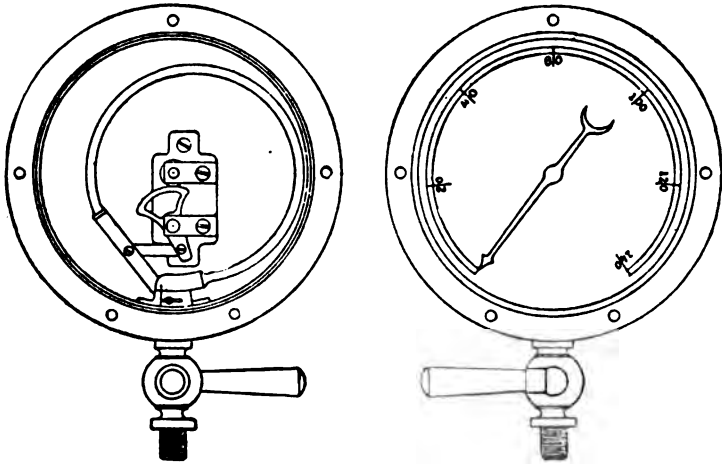

Figs. 138 and 139.—Interior view and dial face of one type of steam gauge. The steam is admitted through the cock at the bottom of the dial box into a flattened and curved tube, which it causes to straighten slightly by its pressure, thus operating the sector and the hand on the dial plate.

causing the link to move the lever. As the lever is dragged by the link, the toothed segment actuates a pinion carrying the hand of the dial on its spindle, thus indicating the pressure, at work against the flattened walls of the tube, on the dial of the gauge, which is shown in the front view.

Most gauges working on the diaphragm theory also have the hand of the dial operated by a toothed sector, link and lever, the latter bearing on the centre of a corrugated diaphragm, A, as shown in the figure. The corrugations of the diaphragm, furnishing a distortable surface, in the same fashion as the flat-

tened walls of the bent tube, move in obedience to the pressure of the steam, as could not be the case, were the diaphragms left flat. However, the degree of corrugation, the diameter of the diaphragm, and the rigidity of the fastening around its edges all serve to render the amount of distortion and consequent elevation of the centre of the disc dependent upon the number of pounds pressure brought to bear. Thus the lever, bearing upon the upper centre of the diaphragm, where the greatest movement must be, is raised or lowered as the pressure fluctuates, actuating the link and toothed segment, and causing the hand to indicate the pounds pressure of steam on the dial.

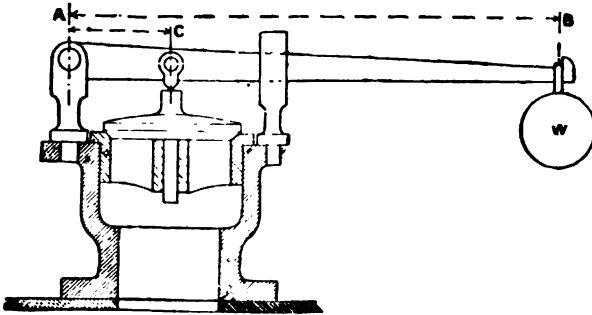
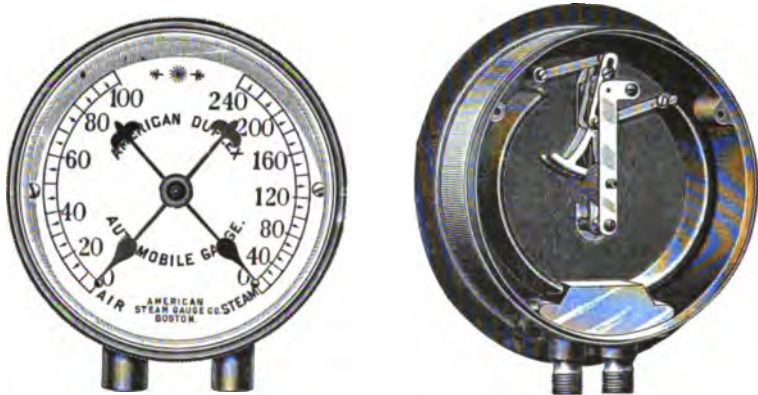

FIG. 140.—A Weight and Lever Safety Valve for a large stationary boiler, shown in section.

Cause and Danger of Excessive Pressures.—Since every boiler is calculated to supply steam to its engine at a certain maximum working pressure—with light steam carriage boilers the usual working pressure is between 150 and 180 pounds—the driver can readily find from his gauge whether or not full power is being generated. Exceptionally high pressures under working conditions indicate a danger point, and in small boilers they are very often due to a low water level, which, unless remedied, will result in burning out. A carriage boiler holding a proper supply of water cannot derive sufficient heat to generate pressures above a certain fixed point, because, as will be explained presently, the fire is automatically regulated. If, however, the water has become exhausted, even though an excessive pressure acts to shut off most of the fuel supply, the metal of the

boiler will become sufficiently heated to collapse the tubes. The enormous heat-absorbing property of water neutralizes the tendency to over-heating of shell and tubes under usual conditions. It is the "dry heat" that must be guarded against in boilers.

So far as the test resistance of small boilers is concerned they should be able to endure pressures far beyond the "blow-off point" of the safety valve. Several American carriage boilers are advertised to have been tested at a "cold water pressure" of 1,000 pounds and over to the square inch. This test is made by inject-



Figs. 141-141a.—Dial and Interior View of the "American" Duplex Combined Steam and Air Pressure Gauge for Use on Steam Carriages. The dial has two hands; one of them attached to a sleeve which works over the spindle carrying the other, in the same manner as the two hands of a clock are hung. As may be readily understood, the two hands work in opposite directions, one clockwise, the other counter-clockwise, from zero to maximum on their respective scales. The sectional view shows the mechanism by which this result is accomplished: two separate inlets, for steam and air, respectively; two distinct flattened and curved steel tubes, each attached at its end by a link to a lever and toothed sector working on the toothed pinion concentric with the pivot of one of the hands. The two flattened tubes, of course, have different tensile ratios, causing them to tend to straighten at different pressures. Hence the steam hand records a maximum pressure of 240 pounds, while the air hand records a maximum pressure of 100 pounds. Duplex gauges of precisely the same construction are used on the air-brake systems of many railroad locomotives—one hand recording the pressure in the air reservoir, the other in the train pipe. The duplex spring used in this make of gauge is so well constructed and so sensitive that it enables the manufacture of the smallest size of gauges on the market. A duplex gauge of this description is shown in place on a steam carriage in Fig. 247.

ing water under such a pressure mechanically exerted or by filling it from vertical tubes of considerable height. Such a test, however, in the absence of heat, indicates only the tensile strength of the metal. For obvious physical reasons, this is quite a different thing from the conditions brought about by the action of the heat.

One case, however, recorded in several motor carriage papers,

might be cited in favor of almost as great endurance under working conditions. As is related, a certain Frenchman, owning an American steam carriage, determined to discover the endurance of his boiler. So, having disconnected the burner regulator and fastened down the safety valve, he allowed steam to generate under full heat. Watching the steam gauge from a safe distance through a spy glass, he allowed the pressure to rise several hundred pounds above normal, and having found that no explosion occurred, concluded that his life and limbs were safe. He rode home in the carriage.

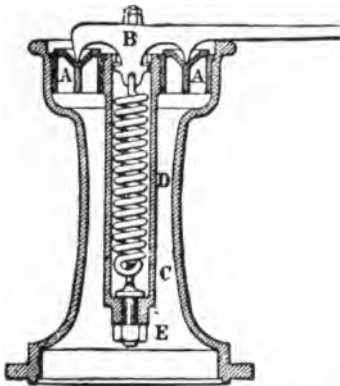

FIG. 142.

FIG. 142.—Form of spring safety valve used on some locomotive boilers. AA are two valves; B, a cross piece bearing on both; D, a spiral spring fixed at C; E, a set screw to regulate tension of spring.

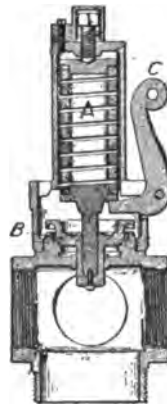

FIG. 143.

FIG. 143.—Section of one type of "pop" safety valve for steam carriages, showing internal construction similar to Fig. 142.

Safety Valves; Construction, Theory and Operation.—The design of the argument up to this point is to satisfy the reader that explosion in a steel-shell, copper-flued carriage boiler is very nearly impossible, and, further, that moderate care and watchfulness can prevent the burning out or collapse of the flues. The unskilled engine-driver is amply protected, if he only exercises reasonable prudence by the automatic burner regulator, the automatic low water alarm, the water glass and steam gauge in plain sight, and lastly by a safety valve adjusted to blow off at the proper pressure.

A safety valve is simply a valve of ordinary description, ar-

ranged to close a steam pipe outlet, under pressure of a weight or spring. The form most commonly used with stationary boilers is the long lever variety, shown in an accompanying figure. It consists of a mushroom valve of ordinary pattern set over an orifice leading from the boiler, so as to be lifted when sufficient pressure of steam bears against it. Over the centre of this valve disc at the point, C, is a lever, one end of which is pivoted at its fulcrum, A, the other end, B, bearing the weight, W. The blow-off pressure, or the point at which the valve opens and allows the steam to escape, may be regulated by the position of the weight, W. According to the law governing levers of this particular variety the blow-off pressure is least when the weight is at the extreme end of the lever, as shown in the cut, and greatest when slid to the opposite end toward the yoke set to steady the lever arm.

The rule for determining the blow-off pressure with such a safety valve is to multiply the length of the lever, from A to B, by the weight of the ball, W; to divide this product by the length of the fulcrum, from A to C.; to add to this quotient the total weight of valve and lever; and to divide the sum, thus found, by the area of the valve. If, then, in a given stationary boiler, the length of the lever is 45 inches; the weight of the ball, 100 pounds; the length of the fulcrum, 5 inches; the weight of valve and lever, 60 pounds; and the area of the valve, 8 square inches, we have in accordance with the above rule:

$$45 \times 100 = 4500, 4500 \div 5 = 900.$$

$$900 + 60 = 960. 960 \div 8 = 120.$$

which expresses in pounds the steam pressure at which the valve will blow off.

Such a form of weight and lever valve is not suitable for locomotives or steam carriages, from the fact that the constant vibration of travel will inevitably unseat the valve and allow the steam to escape before the desired pressure is generated. Consequently, several varieties of spring and direct weight valves have been devised for use on locomotives. In these valves the desired pressure is determined by adjusting the tension of the springs, which are of such strength and rigidity as not to yield to any pressure below that required. This is the principle applied in the common forms of spring scales, used by

butchers and other merchants, and is efficient in both applications, from the fact that a compressible or extensible spring acquires greater rigidity under mechanical strain or pressure, then requiring greater stress to cause it to yield as desired. In calculating such valves, the area of the opening and the strength and tension of the spring are the important considerations. Thus, as given by several authorities, the rule for calculating a valve of this description is to "multiply the area of the opening in square inches by the greatest steam pressure in pounds per square inch that the boiler is intended to bear." Thus, if a valve have an opening of two inches diameter, which means an area of 3.14 square inches, and the boiler is intended to blow off at 250 pounds pressure per square inch, we have: $250 \times 3.14 = 785$, as the expression for the number of pounds pressure that must be brought to bear upon the valve spring. If, however, the opening is $\frac{1}{2}$ inch diameter, as in some carriage boiler valves, and the blow-off pressure be 250 pounds, as many state, we have: $250 \times .19635 = 49.09$, as the necessary pressure on the spring. With an area of opening of .994, which is approximately one square inch, and represents a diameter of $1\frac{1}{4}$ inch, we have, by the same process 248.5 pounds, as the indicated required pressure on the spring.

The safety valves used on steam carriages are constructed on the same general principles as any of the spring valves used on locomotives, or other boilers. They are usually known as "pop" valves, from the fact that the steam in lifting the valve from its seat usually makes a "pop" or sudden detonation. As a usual thing carriage valves are adjusted to a fixed pressure, which is never disturbed.

As will be seen later, several steam carriages and wagons have safety valves which combine the functions of automatic by-pass controllers; not only operating at a stated pressure but also opening the by-pass valve and allowing the water from the pump to return to the tank. Such devices are used with the Serpollet and White flash generator systems.

CHAPTER TWELVE.

SMALL SHELL AND FLUE BOILERS FOR STEAM CARRIAGES.

Small Shell Boilers for Carriages.—Many of the best known makes of American steam carriage have vertical fire-tube shell boilers, usually placed beneath the seat. All such boilers are of small dimensions, frequently little over one foot in either diameter or height, with a consequently small water capacity. But they have a very extensive heating surface, owing to the insertion of a large number of fire flues, and, according to many showings, seem capable of generating a power pressure far in excess of the usual rule of proportions for surface. The shells of such small boilers are usually of steel, sheet-riveted or cold drawn piping, with a thickness ranging between three-sixteenths inch (as given for the Marlboro and Victor steam carriages) and five-sixteenths inch (as given for the Foster steam wagon). Such boilers admit a working pressure of between 150 and 180 pounds to the square inch, with blow-off pressure between 225 and 320 pounds, several of them claiming to have withstood tests of more than three times their blow-off pressure. The flues of such small boilers, which are generally of copper, about one-half inch in diameter and 16 B. W. G., or .065 inch thick, are expanded into the tube plates at either end, the joints being secured as strongly as possible.

Heating Surface of Small Boilers.—The immense heating surface afforded by using a large number of such flues in a boiler of moderate dimensions may be illustrated by the following figures:

In the ordinary two and four-seat carriages made by the Locomobile Company of America a boiler is used whose dimensions are 14 x 14 inches, with 298 half-inch copper tubes.

Computing for the area of a circle of 14-inch diameter we find it to represent 153.94 square inches, which gives 307.88 square inches as the surface of both tube plates.

Computing for the cylindrical surface of the shell, we find the

circumference to be the product of 14 (diameter) and 3.14159 (ratio between circumference and diameter of a circle), giving 43.9822 inches as the circumferential measure, which, multiplied by 14 (length of shell), gives 615.7506 square inches, or a total surface for the boiler shell of 923.63 square inches, or 6.39 square feet.

With the flue-tubes we may calculate in similar fashion. Thus the inside diameter of each tube is approximately one-half inch, exactly .437 inch. To find the inside circumference, we multiply .437 by 3.14159, which gives us, in full, 1.37287483. Multiplying this by 14, to find the area of each tube, we have 19.22024762

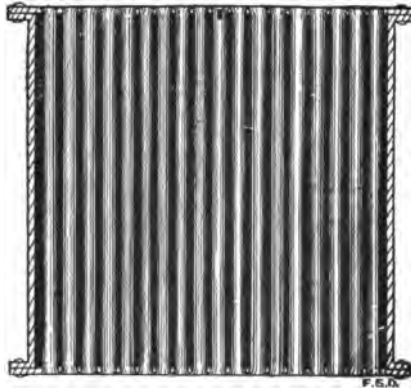

FIG. 144.—Copper Shell and Flue Boiler, with flange connections for the tube plates, as used on the "Locomotive" and other American steam carriages. The shell is strengthened by winding several layers of steel piano wire around the length of the boiler. This cut gives a section on the centre, showing one row of flues.

square inches, which multiplied by 298 (total number of tubes) gives us 5728.633 square inches, or 39.782 square feet, as the heating surface represented by the flues, over six and one-half times the total outside surface of the boiler shell. If to this figure we add 307.88 square inches, or 2.13 square feet, the surface area of the two tube plates, we have 41.91 square feet, as the total heating surface of the boiler.

According to the rule given above, a boiler of such dimensions should be able to drive an engine of about three-horse power. But it has been claimed that this make of boiler has developed over four-horse power, which fact is probably due to rapid steam

generation under fire from a powerful burner, and also the efficiency of the engine used. Similarly excellent results have been achieved with other makes of fire flue vehicle boilers, a fact which simply justifies the course followed by most American carriage builders, of adopting a steam generator of familiar pattern and increasing its efficiency along concurrent lines, instead of spending time and energy in the effort to produce an instrument, which should embody the requirements of perfection.



FIG. 145.—Small Carriage Boiler made from a seamless steel pressing, the lower tube plate being flanged over and riveted in, as indicated at the base of the figure, this being the only seam in the structure.

The Flues of Small Boilers.—Several carriage builders still cling to the practice of using steel tubes in their boilers, thinking by this means to supply an additional assurance against explosion. The custom is growing, however, of using cold drawn copper tubes for this purpose, and experience seems to warrant the statement that boilers containing them are quite as durable as those constructed of steel throughout. Copper is superior to steel in boiler construction from the fact that it has a much higher thermal conductivity, involving considerably smaller loss of heat in proportion to its exposed surface; also from the fact that it

more easily resists the chemical action of impure water, in point of preventing both corrosion and the deposit of incrustations, and is less liable to oxidation from the action of heat. On the other hand, it is inferior to steel in the fact that its tensile strength is greatly reduced under increasing temperatures. As quoted by several boiler authorities, its diminution of strength increases from .0926 as compared to steel at 270 degrees, Fahrenheit, to .2133 at 460 degrees, .2558 at 532 degrees and .3425 at 660 degrees. Well-made copper tubes, however, can readily withstand



FIG. 146.—Bottom View of a Type of Boiler shown in Fig. 145, exhibiting the method of riveting in the lower tube plate.

a constant working pressure of between 150 and 180 pounds to the square inch, which figures represent the average used in small vehicle boilers. These advantages in copper, both pure and in alloy, led long since to the use of brass tubes in some locomotive and other large boilers, with the best results. For this purpose brass proved far superior to iron, or steel, in resisting the abrading action of small particles of coke or coal drawn through the draught; in having a greater power of springing under increased expansion, and of being less liable to break. On the other hand, if we may deduce a principle from practical

experience on this point, the inferior strength of copper tubes for boilers is a positive advantage, for, since they are more liable to collapse under stress of over-heat and expansion, the effect may be similar to that found in water-tube boilers under similar conditions—the bursting of one or two tubes instead of a disastrous rending of the outer shell. This seems to be the experience in some cases. A prominent steam carriage concern says of its tubular boiler: “If the boiler should accidentally be allowed to run dry and become overheated, all that has ever been known to



FIG. 147.—Another type of Small Carriage Boiler, showing both tube plates inlanged and riveted to a seamless steel tube.

happen is that the tubes collapsed at the ends and the boiler leaked. The water and steam escaping gradually reduce the pressure until none is left—the result of which is that the tubes (a number of them) are ruined and must be replaced.”

On the matter of metal and metal combinations suitable for use in boilers, the following is quoted from an excellent article on the subject:

“The question of the strength of materials for boilers was elaborately tested some years ago by the Franklin Institute. It was then found that the tenacity of boiler plate increased with the temperature up to 550 deg. Fahr., at about which point the tenacity began to diminish as the temperature rose. At 32 deg. Fahr. the cohesive force of a square inch section was 56,000 lbs.; at 570 deg. it was 66,500 lbs.; at 720 deg. it was 55,000 lbs.; at 1,050 deg. 32,000 lbs.; at 1,240 deg. 22,000, and at 1,317 deg. 9,000 lbs. Copper follows a different law and appears to be diminished in strength for any increase in temperature. At 32 deg. Fahr. the cohesion of copper was found to be 32,800 lbs. per square inch section, and exceeds this cohesive force at any higher temperature, the indications being that the square of the diminishing strength keeps pace with the cube of the increased temperature. Strips of iron cut in the direction of fiber were found to be 6 per cent. stronger than when cut across the grain. Welding was found to increase the tenacity of the iron, but welding together different kinds of iron was not found to be favorable. Overheating was found to reduce the ultimate strength of plates from 65,000 to 45,000 lbs. per given section, and riveting of plates was found to diminish the strength one-third.”

Steam Feeding Apparatus.—In general, one of the gravest difficulties experienced in small boilers with a large number of fire flues and consequently small clearance, or water space between them, is the danger of priming. This danger assumes graver proportions when we consider the small cubic content of the cylinders, which would speedily operate to disable the engine, were it not that some means were adopted to insure the delivery of perfectly dry steam. This end is achieved by some boiler-makers by the use of a *baffle plate*, a metal sheet of slightly smaller diameter than the boiler, which is fixed above the water level and somewhat below the upper tube plate, so that the small clearance all around will permit the steam to rise and emerge through the steam pipe fixed in the upper plate, while at the same time effectually confining the water circulation to the space below it. Such a device is particularly efficient when used in connection with a *separator*, or pipe of large diameter running across the diameter of the top plate, connection being made with the steam space at the centre of the plate and, with the feed pipe to the en-

gine, by another pipe contained within the separator and having a number of small holes drilled in its length. In this contrivance an extra precaution is found against the escape of unvaporized water. Any form of separator may be utilized for this purpose. A device of somewhat similar description is used in the Stanley carriage boilers as an "internal dry pipe," being inserted in the length of the boiler, closed at the lower end and having the entrance very little below the top tube plate. The steam feed pipe, also closed up at the bottom and having a large number of small holes in its length, is enclosed within the first pipe and emerges near the top of the shell. Other manufacturers claim that the



FIG. 148.—The Boiler used on the "Victor" Carriage, Top View, showing asbestos packing, steam and water connections, and method of riveting on the tube plates.

end of securing dry steam feed is insured by maintaining the water level at a point about midway in the water chamber, thus allowing space for extra expansion, but it is probable that the majority also employ either the baffle plate, the internal dry tube, or some contrivances of their own to add extra assurance of the result.

Data on Some Carriage Boilers.—As many American automobile manufacturers use vertical tubular boilers for steam generation, it is necessary to a good idea of the situation to give data

regarding only a few selected types. The boiler used in the carriages of the Stanley Manufacturing Co., of Boston, Mass., is made of fire box steel plate, 5-32 inches thick, 14 inches in diameter by 13 inches in height. The longitudinal joint is quadruple-riveted, double butt-strap joint; the upper tube plate is flanged out and inserted; the lower plate is riveted to a lateral flange on the end of the cylindrical shell. There are 295 fire tubes of about one-half inch diameter, and the dry steam tube previously mentioned, giving a total heating surface of about forty square feet, and a nominal rating of about four-horse power. All connec-



FIG. 149.--The Boiler used on the "Victor" Carriage, Bottom View, showing blow-off and steam superheating tube. In this boiler the steam connection is through a tube, about $\frac{3}{8}$ inch below the upper tube plate, which passes down through the lower tube plate and is carried over the burner, as shown. The steam pipe then passes up through the lagging around the boiler and connects with the engine from the top.

tions are made in the length of the shell, and include a pop safety valve, check valve for water, steam and water level gauges, the whole being covered in with a jacket of magnesia plastic composition sheathed with aluminum. The total weight is about 110 pounds. The feed water is pumped through a coil of pipe within the burner space, ensuring a temperature of at least 100 degrees under working conditions before entering the boiler.

The Stanley boiler, worthy of mention on account of several

excellent features, is a good type of one theory of boiler construction as applied by manufacturers of steam carriages, that of constructing the shell of sheet metal, bent into shape and riveted. Another theory which is embodied in several well-known makes of carriage is that of using a seamless cold drawn tube as the basis of the cylindrical shell. This construction is found in the Locomobile, whose boiler has been described above, and in the

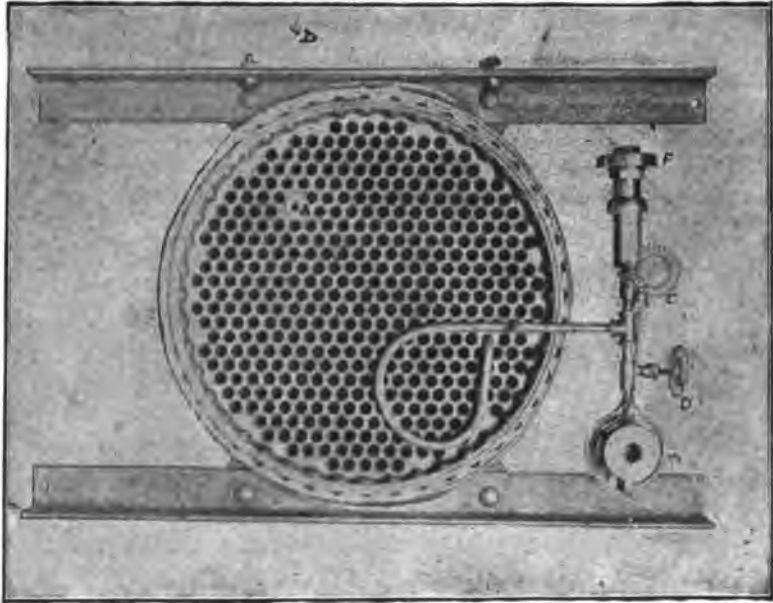

FIG. 150.—Bottom View of the "Reading" Carriage Boiler, showing the arrangement of the flues in the crown sheet; also, method of riveting on the head, non-conducting boiler lagging, and attachment of boiler to two angle iron supports running in the width of the carriage. The liquid gasoline is fed from the storage tank through a tube passing to the top of the boiler, thence down through one of the flue tubes, and, in the loop, here shown, over the burner flame, into the regulator and distributor. F is the automatic fuel regulator; E, the preliminary vaporizing coil; C and D, valves controlling the feed; A, the fusible plug. The operation of the fuel feed will be explained in the chapter on burners.

light carriages of the Milwaukee Automobile Co., the Steam Vehicle Co. of America, and several others. The result is said to be greater strength than can be secured in rivet construction; there being no seams to break under strain and no joints to be weakened by the action of heat. The Locomobile boiler is inter-

esting from another feature, which admits not only of the use of lighter plates, but also of a copper shell, a cold drawn copper tube of 16 B. & S. wire gauge, or about one-twentieth inch thickness. Around this shell, to afford the proper degree of tension, are wound two layers of steel piano wire. The ends of the tube are flanged outwardly, the tube plates being laid flat upon them and riveted into place with a steel strengthening ring on the inner side to take the heads of the rivets. This construction may be understood by reference to the sectional drawing of this carriage.



FIG. 151.—A Lane Steam Surrey. Several mechanical details used on this carriage will be described later.

The following figures represent the dimensions of a few other well-known makes of carriage boilers :

Milwaukee.—Length, 14 inches ; diameter, $16\frac{1}{2}$ inches ; number of tubes, 350 ; diameter of each, $\frac{1}{2}$ inch ; heating surface, 50 square feet ; working pressure, 150 pounds.

Kidder.—Length, 18 inches ; diameter, 16 inches ; number of tubes, 326 ; diameter, $\frac{1}{2}$ inch ; heating surface, 56 square feet.

Victor Steam Carriage.—Height, 13 inches ; diameter, 16 inches ; number of tubes, 425 ; diameter, $\frac{1}{2}$ inch ; heating surface, 54 square feet ; working pressure, 180 pounds.

Foster Steam Wagon.—Water content of boiler, $6\frac{1}{2}$ gallons ; number of tubes, 200 ; diameter, $\frac{1}{4}$ inch ; working pressure, 180 pounds.

CHAPTER THIRTEEN.

OF WATER-TUBE BOILERS, AND THEIR USE IN STEAM CARRIAGES.

Of Tubular Boilers in General.—The recent immense popularity of motor vehicles has occasioned a corresponding activity in the production of all kinds of improved devices and appliances—in no respect more than in the domain of steam generators. While, as has been stated, most American steam carriages carry cylindrical flue boilers, which have been brought to a high degree of perfection and steaming capacity, a number of manufacturers have adopted some form of water-tube or flash boilers, with equally good results. One reason, perhaps, for this innovation lies in the fact that water-tube boilers are supposed to be more secure from disastrous explosions, and another, that their evaporating capacity, per square foot of heating surface, is rated higher. As a matter of fact, however, neither consideration maintains fully; since the common pattern of carriage flue-boiler, with its multitudinous tubes and small water space, differs from the best water tube boiler of the same size only in constructional details. It is inferior to it only in the small point that the tube layers of a water-tube boiler may be staggered, and thus enabled to intercept a much larger proportion of heat than could be absorbed in a straight flue. As regards the matter of immunity from explosion, the use of copper flues, as we have seen secures this result for the shell boiler quite as effectively as for the other variety.

Directing the Circulation.—There is a point, however, in which the interest of inventors in tubular boilers may be fully understood, which is that by suitable arrangement of the tubes the circulation of the heated water may be controlled to the most rapid generation of steam. Hence it is that, in overlooking the files of the patent office and of the current motor vehicle press, we find so large a variety of seemingly fantastic combinations of bent tubing, each of which is proposed by its inventor as the newest and highest achievement in steam generators. The rea-

son for this seeming waste of energy and ingenuity is that the problem of how best to control the circulation, to the ends of quick steaming and higher durability, through more uniform distribution of heat, has by no means been finally solved. This means that, although very many varieties of tubular boiler possess high efficiency as generators of steam, none of them attain such great power for absorbing heat but what there is still room for efforts to discover some means of neutralizing waste in this particular. In a generator built like an ordinary kettle, without flues or screens to control circulation, the rising and falling currents interfere with one another, with the result that the distribution of heat is not regular, and "boiling-over," or "foaming," is

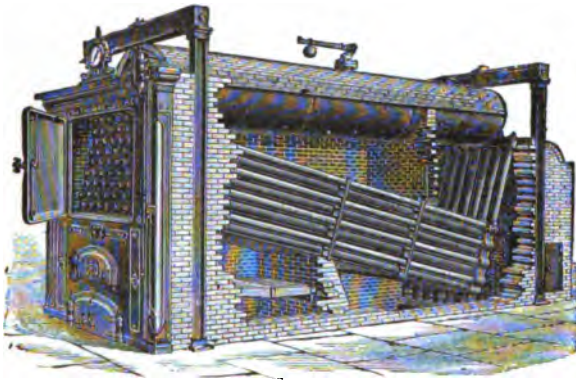

FIG. 152.—A large Water-tube Boiler, showing the general construction; a nest of water tubes in communication at both ends with a steam drum at the top.

liable to result. Such an effect in a steam engine boiler would mean that water is fed to the cylinders, along with the steam necessary to produce motion; which is to say, spray would be mingled with the dry vapor, to the speedy detriment of efficiency. Since it is most desirable that the steam should be dry, the necessity of mechanically controlling circulation is obvious.

Advantages of Controlling Circulation.—Furthermore, by suitable arrangements for directing the rising and falling currents, so that interference is obviated, another very desirable end is attained—chemical impurities, held in solution by the water, and precipitated, so as to form scale deposits, when it is evapo-

rated, are prevented from locating and hardening; being received into mud drums suitably arranged at the lowest point of the water chamber, where they can be conveniently removed. According to statistics furnished by various authorities these scale deposits, consisting mostly of lime and other non-conducting substances, interfere with the heat-conducting properties of the metal to an enormous extent: A deposit of 1-16 inch involving a loss of 13 per cent. of the fuel; a deposit of $\frac{1}{8}$ inch, a loss of 25 per cent.; a deposit of $\frac{1}{4}$ inch, a loss of 38 per cent.; a deposit of $\frac{1}{2}$ inch, a loss of 60 per cent. The result of allowing such incrustations to increase will be inevitably that the metal surface exposed to the fire is burned out and the boiler ruined.



FIG. 153.—A "Toledo" Runabout. One of the well-known makes of American steam carriage using a water-tube boiler.

Advantages of Sectional Construction.—Another very desirable quality found in water-tube boilers—it holds, in fact, for most of the efficient boilers used in motor carriages—is that the sectional construction, involving a distribution of pressure through a large series of small areas, is an excellent means of preventing disastrous explosions, such as must result when most of the pressure is centered on an extensive area like the shell of a large cylindrical boiler. This large shell can undoubtedly stand a much higher pressure before yielding, but this fact involves a terrific catastrophe when once that breaking point is reached. A smaller and lighter tube may be rent by a comparatively slight

pressure, but its rupture means only a local explosion of small extent and power for harm.

General Advantages of Water-Tube Boilers.—To sum up the advantages of water-tube boilers, we find that the plan of breaking up the generator into a train of tubes, suitable for controlling the circulation, increasing the heating surface, and enabling proper separation of both steam and sediment from the liquid water, both increases the efficiency and decreases the danger. Since both these considerations are of the utmost importance in motor carriages, which are most often handled by persons unskilled in mechanical science, it is obvious that the water-



FIG. 154.

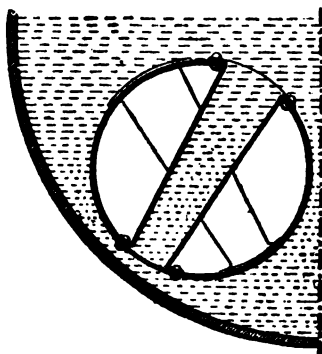

FIG. 155

FIG. 154.—Diagram of Circulation in a Steam Boiler, showing the general directions to be controlled by tubular trains in water tube boilers.

FIG. 155.—The Galloway Tubes of the Lancashire Boiler. These tubes, which are set across the large smoke flues, illustrate one of the earlier devices for controlling circulation.

tube boiler, or, at least, some type embodying a majority of its features, is most desirable. The following quotation from a paper, read before the Society of Naval Architects and Marine Engineers, by Capt. George W. Melville; U. S. N., shows the situation on the subject in the minds of competent engineers. He says:

“The fact that water-tube boilers raise steam quickly is of the greatest advantage. I have stated elsewhere that I consider the battle of Santiago to have developed the necessity of the use of water-tube boilers, whether it taught us anything else or not. It would have been of the greatest advantage to have had during the blockade of Santiago boilers capable of

raising steam in less than half an hour. Coal need not have been used to keep all the boilers under steam all the time. The Massachusetts might have shared in the glories of the fight if she had been fitted with water-tube boilers. The Indiana would have kept up with the Oregon and the Texas. The New York would have developed at least three knots more speed and the navy would have been spared a controversy. I think the Colon would not have gotten as far away as she did. But we did not have the water-tube boilers."

The "Pros" and "Cons" of Water-Tube Boilers.—An English authority on boilers, Edwin Griffith, in a paper read before the Northeast Coast Institution of Engineers and Shipbuilders, states the following advantages and disadvantages involved in the use of water-tube boilers. Under the head of advantages, he enumerates: (1) reduced weight; (2) quicker steam generation; (3) small dimensions of the parts subjected to pressure; (4) small amount of contained water, rendering explosion less serious; (5) ability to endure sudden changes of temperature. Under the head of disadvantages, he enumerates: (1) the necessity of regular and constant feeding of water; (2) the difficulty of access to the interior of tubes to remove deposits; (3) the impossibility of plugging a leak without putting a boiler out of service; (4) the fact that the average water-tube boiler will not stand neglect and rough usage as well as the fire flue variety. The last consideration applies particularly to boilers intended for use in motor carriages, which should be particularly designed to withstand neglect and handling by unskilled engineers. Mr. Griffith also mentions as possible and general objections the facts that (1) the comparatively small area of water and steam surfaces often involves a greater liability to prime than is found in flue boilers, with the result that some simple form of separator should always be used; (2) the necessity of insulating the fire space, so as to offset the radiation of heat and prevent setting fire to surrounding objects; (3) the combustion space is frequently too small for the expected generation of power; (4) the constant danger of burning out the tubes nearest the fire when a tortuous circuit for the burned gases is provided.

The causes of corrosion he sums under five heads: (1) the admission of oil into the feed water; (2) solid matter in the feed

water, liable to be precipitated and form deposits; (3) air in the feed water, liable to cause oxidation of the heating surfaces; (4) carbonic acid in the feed water, liable to produce unfavorable chemical action, and to be neutralized by the use of caustic soda; (5) galvanic action, causing corrosion, due to want of uniformity, almost always found in the materials composing the various parts.

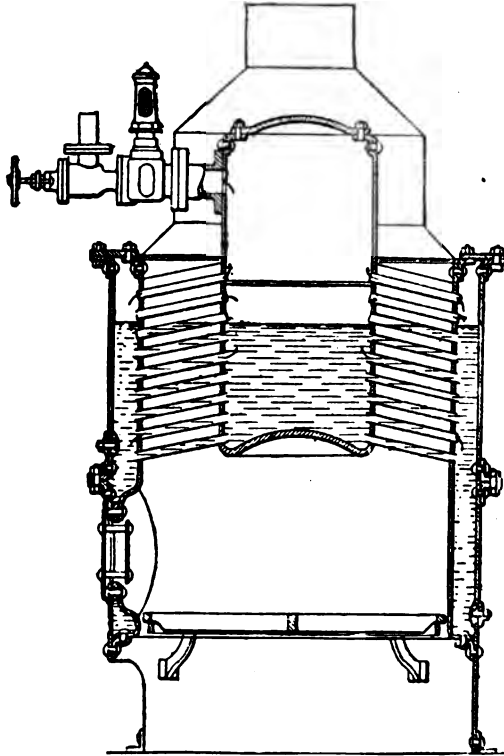

FIG. 156.—One form of the De Dion Tubular Boiler. It consists of an outside annular chamber, forming a waterleg and connected by numerous inclined tubes to the inner steam and water chamber. A partition across this inner chamber secures dry steam for the engine. Steam connections at the top.

Advantages of Water-Tube Boilers.—With the water-tube boiler, on the other hand, the fact that the full force of the steam pressure cannot bear on any one extended surface involves that in the event of overheating or sinking of the water level, only one

or two of the tubes will burst with no very serious consequences. Wellington P. Kidder, a boiler expert, enumerates the following ten points of structural advantage in a well-made water-tube boiler, adapted for road wagons: *

(1) The water should not be expelled by heat from the tubes nearest the fire; (2) foaming and priming are no more likely than in shell boilers; (3) there need be no joints near the fire; (4) there may be but few parts, easily and cheaply assembled; (5) the weight is about two-thirds that of a shell boiler of equal capacity; (6) being in sections, it may be easily taken apart for cleaning or repairs; (7) an easily removable casing will deflect downward any escape of steam or water, due to breakage of tubes; (8) a natural and rapid circulation through all tubes insured; (9) ample provision for insuring dry steam for the cylinders; (10) the ready possibility of blowing steam through the tubes for removing incrustations, also, between them, for removing soot. In a compliance with such conditions in construction he finds the following eight points of superiority: (1) All danger minimized; (2) steam quickly generated; (3) weight minimized; (4) superior absorption of heat by inclined tubes; (5) more heating surface found on exterior of tubes; (6) less opportunity for dust accumulation; (7) higher working pressure of steam practicable; (8) better elastic provision for expansion. He confesses, however, that most of the really practical water-tube boilers for vehicles present some one or all of the following three disadvantages: (1) Too much bulk and complication; (2) liability to foaming and priming; (3) danger of expulsion of water from the tubes nearest the fire by overheating. The last-named fault, if not the others also, is to a large extent offset in the De Dion, Weidnecht and Clarkson-Capel water-tube generators by the lower chamber or water-jacket; and, in the Lifu generator by the trunk tube and water arch features. The Lifu generator is nearly the most elaborate attempt yet made to mechanically control the water circulation. In the ideal water-tube boiler, however, the tubes would run across the draught through a portion of their length, at least, thus making possible a greater absorption of heat, through the breaking of the air currents. This result is im-

* "Horseless Age," Dec. 6, 1899.

mensely increased when the successive rows of tubes are staggered, so as to still further divide up the draught currents.

The Field Finger-Tube Boiler.—A type of water-tube boiler, which has given good service in several steam carriages, notably the Thomson-Ransome coach, built about 1870, and the Valee coach, built about 1880, is of the ordinary fire-engine upright pattern, with a central smoke flue controlled by the form of baffle damper, for regulating the heat currents, shown in the

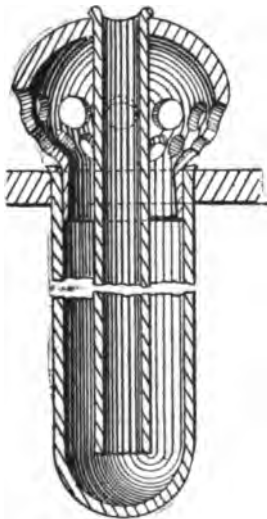

FIG. 157.

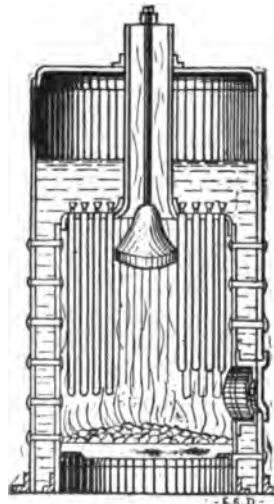

FIG. 158.

FIGS. 157-158.—Field Water-tube Boiler and one of the Field Tubes, showing inner tube and method of controlling circulation. A number of such tubes are hung over the fire box of the boiler, as shown.

accompanying figure. Instead of fire tubes or coils, it has the bottom crown plate fitted with a number of suspended "finger tubes," through which, on account of the peculiar shape of the movable baffle damper, the heated gases are forced to circulate. Each of these tubes, which is closed and rounded off at the bottom end, like a chemist's test tube, is inserted and expanded in an aperture in the crown sheet. In this inner open end, as shown, is inserted a second smaller tube, which, in turn, depends from

a perforated globe, or a suitable collar, the three elements being firmly attached. In the style of Field tube shown in the figure, the perforated globe carries a tapering ferrule that is driven into the end of the outwardly hanging finger tube, thus further securing the joint.

The operation is to be understood readily: The water in the lowest level of the finger tubes is directly affected by the heat of the furnace, and rises along the sides; the descending strata, working down to take the place left by the rising mass, moves through the orifice at the top of the globe and down the central tube. The circulation is thus perfectly guided and, all interference of the rising and falling currents being prevented, the greatest possible percentage of heat is utilized. In spite of the high efficiency of Field tube boilers, they have been almost entirely supplanted in the domain of motor vehicles by other types less difficult to construct and maintain.

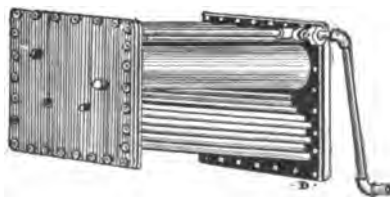

FIG. 159.—The Sterling Water-tube Boiler.

The Sterling Light Carriage Boiler.—From among the tubular boilers that are, or have been, in actual use on motor vehicles a few have been chosen for brief description, on account of some original or excellent features. The Sterling tubular boiler is one of the most typical of its kind, and very well illustrates the essential features of water-tube boilers as used for all purposes. It consists of two heads, a longer and a shorter one, as shown, each of which is formed of two plates of boiler iron, flanged and bolted together, so as to leave a shallow chamber between each two plates. The heads, thus formed, are connected together by three tiers of water tubes: The lowest tier, a number of rows of small steel tubes, tilted upward from the water intake at the base of the longer tube plate, and staggered, as shown, so as to absorb as much heat as possible, and control the

circulation of the contained water; the middle tier, consisting of three tubes of large diameter fixed just above the water level, so as to form suitable steam drums; the upper tier, consisting of three rows of tubes similar in diameter to the lowest rows, and also staggered, run parallel to the steam drums, and serve as a superheater for the steam. The steam out-take is situated, as shown, at one end of the superheater tubes. The manufacturers of this generator claim a very high efficiency in steam generation, and allege that the heads will withstand a pressure of 60,000 pounds per square inch, and the tubes, all formed of seamless cold-drawn steel tubing, a constant pressure of 400 pounds. They claim, also, that, with an efficient burner, 20 pounds, gauge, of steam

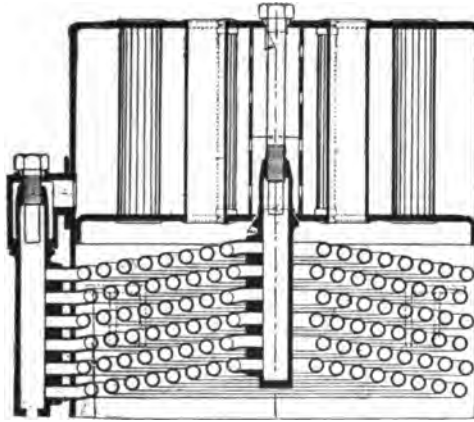

FIG. 160.—The Geneva Carriage Boiler. This boiler consists of several coils of tubing connected at inner and outer extremities to headers, as shown. The water and steam chamber above is constructed like an ordinary flue boiler.

can be generated in two minutes, and 140 pounds in five minutes. The head plates may be removed, without taking the boiler from the carriage, and the entire system of tubes thoroughly cleaned, which feature greatly adds to the convenience of the boiler.

The Geneva Tubular Boiler.—Several other manufacturers of steam carriages have adopted boilers similar in general features to the Sterling, but experience seems to prove that those who do not use the familiar flue boiler have some form of multiple coil

generator, such as are about to be described. Two of the best designed among the coil boilers are the Geneva and the Toledo, named respectively as the carriages they propel. The Geneva boiler has the general characteristics of water-tube boilers, but has been well described as a "combination of tube and flue boilers." It consists of six somewhat conical superposed coils of $\frac{5}{8}$ inch seamless cold-drawn steel tubing, each 17 feet total length, which are pinned and brazed to a header, or manifold tube, both at the centre of the coils and at the outside extremity. These two "headers" serve the same ends as do the head plates of the generator just described; being simply common chambers in which the water may pass from one coil to another, as impelled by the tendency of circulation. Thus the tendency within the inner header is from the lower to the higher coils and within the outer, the reverse. By this means the circulation is directed into its natural channels, and, at the same time, the water within the coils is exposed to the greatest possible area of heat. The heat is also largely economized, as in most tubular generators, by staggering the rows of tubes, thus repeatedly deflecting and breaking up the current of burning gas, as it moves upward to the vent. The water intake is at the base of the outer header tube, and the feed water, as it enters, is urged into the coils by the pressure of the circulating liquid; its temperature being immediately raised by contact with the heated tubes. Both headers are secured by bolts to the drum above the tiers of coils, as shown, and open into it by ports that permit the steam to be given off, and any water escaping to follow the general direction of circulation. This drum is, in fact, a flue shell boiler, being pierced by 16 flues of $1\frac{3}{4}$ inch diameter, which enable the superheating of the steam, as the products of combustion pass through them.

The generator thus formed shows a very high efficiency in steaming and a practically complete immunity from explosion. Actual experiments, it is stated, have shown that, in the event of the water supply being exhausted, the engine will merely stop, and no disastrous consequences will follow. The tubes then being heated in the flame of the burner, which is controlled by a diaphragm regulator, such as will be later described, steam evaporation begins again as soon as the water is injected, the action then being, in fact, somewhat on the order of the "flash" generators.

Although not intended to act as a flash boiler, it is probable that the coil design would need but little alteration to enable it to do so. Furthermore, the crown sheet of the steam chamber above the coils is so far removed from the fire that the flues cannot be injured or burned out, even if the water is carelessly allowed to become entirely evaporated. The chamber adds capacity for steam generation, and keeps the steam supply at a point quite independent of the rate of water supply, which is of itself a valuable item in a motor carriage boiler, where the demand is usually very



FIG. 161.

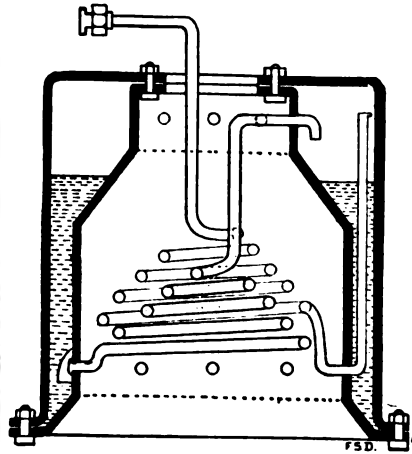

FIG. 162.

FIGS. 161-162.—Outside and Sectional Elevation of the Morgan Boiler used on the Toledo Carriage. The disposition of the coils may be understood from these cuts, also the steam connections through the superheating coil. The sectional view shows the steam superheating and one of the generating coils in position, with connections indicated for other coils. As shown, the steam enters a vertical tube somewhat below the top of the steam space; thence flowing downward, through one of the coils above the fire and out to the engine through the feed pipe.

uneven. It is also a desirable feature not possessed by the general run of water-tube boilers.

The Geneva boiler is 8 inches high, measured from the base to the apex of the coned coils, and the water chamber measures 9 inches from the crown plate, giving a total height of 17 inches. It is also 17 inches in diameter. The engine which it supplies is rated at 6 horse-power, gross, which represents an excellent average of output for its 29 1-3 square feet of heating surface being, in fact, 1 horse-power at the boiler for each 5 square feet.

The Toledo Water-Tube Boiler.—The Toledo boiler, although differing considerably in some particulars, is constructed on the same general principles as the Geneva. It consists of an annular water and steam chamber, formed by bolting together two seamless steel shells, suitably shaped as shown, within which eight slightly coned coils of $\frac{3}{8}$ inch steel tubing are attached at top and bottom. The outer connection of each of these coils is near the bottom of the annular space, instead of in a header of any description and the centre connection is near the top of the chamber. The attachments of all the coils, both at the top and at the bottom, being on horizontal planes, perfect circulation is made possible from the lowest point of heat contact upward. Because of the excellent character of these circulation guides, dry steam is fed to the engine, without danger of priming, the annular steam space serving as a centrifugal separator. The dimensions are 19 by 19 inches, but $1\frac{1}{2}$ inches of asbestos packing gives a total breadth of 22 inches. A heating surface of 38 square feet is reckoned, on which is claimed 1 horse-power for every 5 feet, giving a total of $7\frac{1}{2}$ horse-power at the boiler.

Since the two seamless shells, forming the annular water and steam space, are bolted together—no rivets are used—they may be readily taken apart for necessary repairs or cleaning. The coils, also, being connected to the shells by joints of special pattern, may be removed with ease.

The Rider Tube Plug Boiler.—The Rider boiler is, perhaps, one of the most radical departures in water-tube generators, devised to meet the requirements of motor carriages for a light, compact and quick-steaming apparatus. It consists, briefly, as shown, of a cylindrical shell, constructed without flues. The lower crown plate contains a number of threaded perforations, into which the tube plugs may be inserted. Each of these plugs, made of brass or steel, as desired, are fitted with nine tubes bent U-shaped, and expanded into holes drilled in the plug. The outer arm of each tube is then countersunk to receive an extra length of slightly smaller diameter, which, being inserted, gives each one the shape of the letter J.

The plugs, thus formed, are inserted in the perforations of the lower crown plate, and screwed home with an ordinary wrench. Any plug may be detached without removing the boiler.

The action of the Rider tubes is very analogous to that of the ordinary Field tube boilers already described. The water circulation, under heat impulse, is downward, at the centre of the tube clusters, and upward, through the outer legs. Since, however, these elongated outer legs are designed to reach above the water level, the resistance experienced even with Field tubes is obviated, and strong jets are thrown upward to a baffle plate placed immediately above them, the water falling thence to the surface

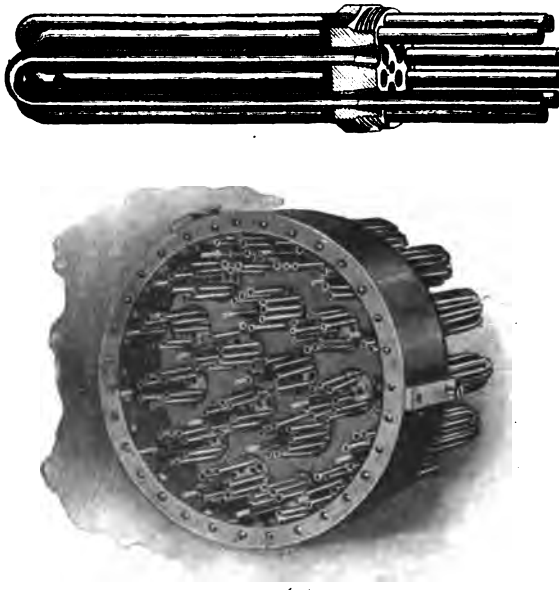

FIG. 163 —The Rider Tube Plug Water-tube Boiler, showing one tube plug and the assembled boiler.

after giving off its steam. The upper crown plate is merely bolted into place, which arrangement permits it to be removed, when desired. The entire structure, water chamber and tubes, is inserted in a suitable external shell, which forms a generator 14 by 14 inches, developing 5 horse-power, gross, at the boiler. Any form of burner may be used, and the greatest possible percentage of heat may be utilized, since the products of combustion are led around the outside of the shell to the vent.

One of the foremost advantages claimed, next to quick and ready steaming qualities, is that the rapid circulation of water positively prevents the deposit of scale in the tubes. Furthermore, the construction being reduced to such exceedingly minute sections, the danger of explosion is made so remote as to be practically impossible. It is also asserted that the boiler cannot burn out, in case the water supply is exhausted.

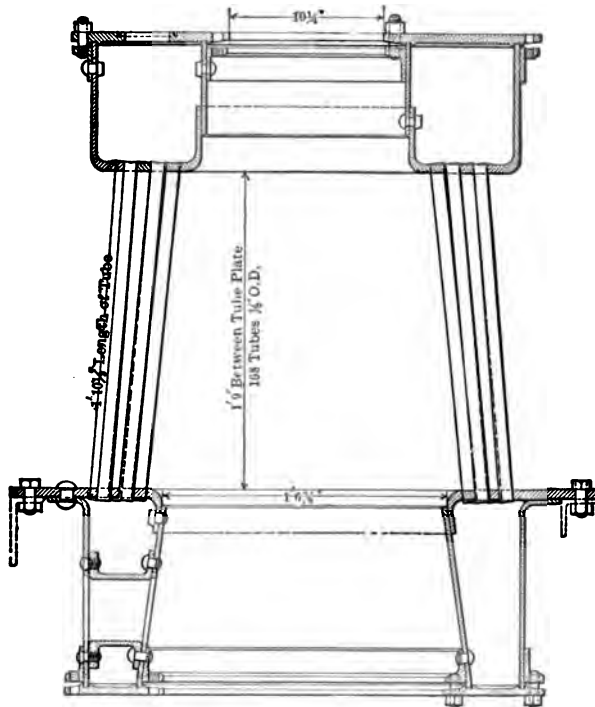

FIG. 164.—The Thornycroft Steam Wagon Boiler.

The Thornycroft Heavy Vehicle Boiler.—The boilers just described, with the possible exception of the last, are manufactured exclusively for light steam carriage use. But such a treatise as the present one would be incomplete without some notice of the numerous types, called into being in response to the demand for generators adapted to the needs of heavy trucks,

lorries and coaches. The achievements of engineers, in the early days of the Nineteenth Century, in producing generators capable of operating their somewhat unwieldy coaches, has been more than outdone in the present day. Perhaps among these heavy-vehicle generators none have proved more efficient than the Thornycroft, whose details are shown in several accompanying diagrams. Briefly, it consists of two annular chambers, one above, one below, connected together by 168 slightly inclined tubes, set four deep in the tube plates and staggered, as shown. Both tube plates are steel pressings, and the upper and lower

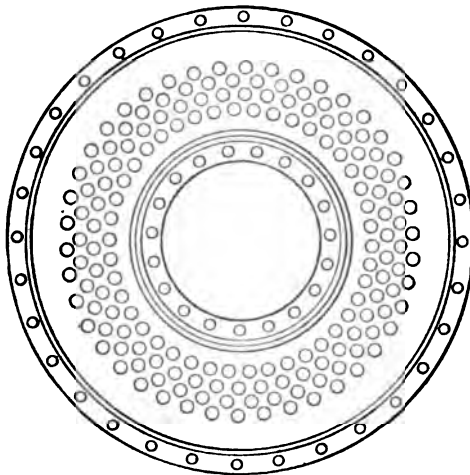

FIG. 165.—Top View of the Annular Pressing, forming the upper or steam chamber and upper tube plate of the Thornycroft boiler. The arrangement of the tubes is shown well in this cut.

chambers are built up on them by ring-shaped sections, suitably riveted. But the top and bottom plates of the boiler are bolted on, as shown, so as to admit of their ready removal for cleaning or repairs. Fuel, usually coke, is fed to the fire through the aperture in the top of the boiler, and, since the grate is situated at a point about the bottom of the cut, the fire is confined below the water tubes, touching no part of the generator except the inwardly-sloping sides of the lower drum. Access to the fire, for the removal of clinkers, may be had through the door shown in the lower drum at about the level of the grate.

The entire structure is sheathed by a suitable casing, which confines the gases of combustion, preventing their escape at all points, except the chimney, which is situated to one side. Here a forced draught is maintained by exhaust steam, as in a railroad locomotive, and the smoke and burned gases, having no other vent, are compelled to pass out through the small spaces between the slanting tubes, thus giving off a very large percentage of their heat.

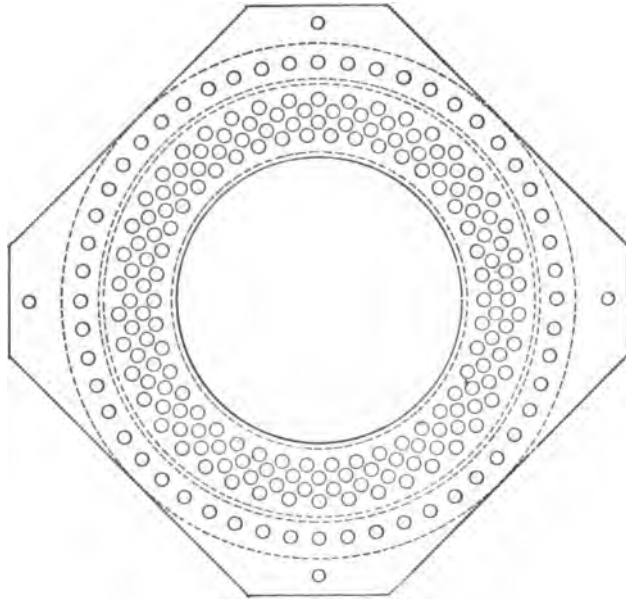

FIG. 166.—Plan View of the Upper Plate of the Lever of Water Chamber of the Thornycroft Boiler. Comparison of this with previous cut gives an idea of the spread of the tubes.

Steam is taken off through the vent shown at the left hand top of the upper chamber, and is fed to the engine through a steam dome. Later patterns of this boiler have also a superheating coil, which carries the steam from the upper part of the chamber to a point directly over the fire, and thence out through this same vent. Water is fed to this boiler by a pump worked by a worm gear on the crank shaft of the engine, or by an injector, when the machinery is not in motion. Two safety valves are also

provided; one blowing off into the chimney, the other, situated at the top of the steam chamber, into the air.

With a generator of this description, something over 3 feet in height, 83 square feet of heating surface is obtained on about 2.4 square feet of grate area. Its usual working pressure is about 175 pounds per square inch, with test at 350 pounds, and sufficient steam is developed to give 20 B. H. P. at 440 revolutions per minute, which represents 1 horse-power at the boiler for each 4.15 square feet of heating surface. Such an average indicates a highly efficient generator.

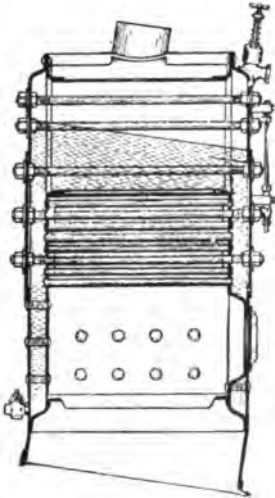

FIG. 167.

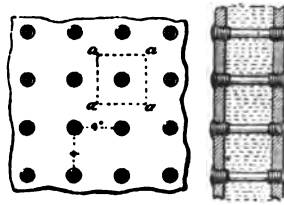

FIG. 168.

FIG. 167.—The Toward Water Tube Boiler.

FIG. 168.—Side Stays, as on the Water-leg of the Toward Boiler. The square marked *a a* indicates the area of pressure which must be reinforced by each bolt.

The Toward Heavy Vehicle Boiler.—The Toward generator, used in the steam wagons and tractors manufactured by Toward & Co., of Newcastle, England, is another example of high-class boiler making. As shown in the figure, its working parts consist of a rectangular-profile water and steam chamber, extending as a water-leg to the level of the grate. Just above the fire box, the front and rear walls of the water chamber are connected by a number of steel tubes—there are about 90 of them in the boilers of this pattern—placed in slightly tilted rows and stag-

gered. These are expanded into the tube plates in the usual manner, and serve as circulation guides. The tilt is given by the backward inclination of the entire structure, as shown. Immediately above the water tubes is a cylindrical steam and water drum, which consists of a length of steel tubing riveted around at each end to annular flange pieces which serve to attach it to the front and rear walls of the tube space, as shown. The products of combustion pass through the spaces between the lower rows of tubes, up and around the cylindrical steam chamber, thence out through the chimney. Steam is taken off through the cock shown at the summit of the boiler. A blow-off cock is attached at the rear near the base.

Needed rigidity is given to this boiler by stay bolts running from front to rear, also connecting the outer and inner walls of the water space around the fire box. By removing these, the tubes may be reached for cleaning or repairs.

With a generator of this description, measuring 2 feet 2 inches across the fire box and tube space, and 3 feet high, a heating surface of 40 square feet is realized; with a height of 4 feet, a heating surface of 65 square feet. The latter style has a record of evaporating about 600 pounds of water per hour at 190 pounds pressure.

The De Dion Boiler. — Another excellent type of boiler for heavy road wagons is that shown in Fig. 169. It consists of two annular, or ring-shaped, cylindrical vessels, *A* and *B*, which are connected together by a number of tubes, *CC*, slightly inclined, as shown. These tubes, about 500 in number, greatly assist the circulation of the water. The vessel, *B*, is divided at about the middle of its length by the partition, *D*, which is efficient in separating the steam chamber from the water and thus enabling the delivery of super-heated dry steam into the cylinders. The feed water, which is delivered to the boiler from a pump operated by an eccentric gear on the crank shaft, passes through the coils, *E*, being thus heated by the fire before reaching the boiler, and the exhaust steam is passed through the coils, *F*, which serve to super-heat it and largely prevent its delivery as visible vapor. The top and bottom of each of the chambers, *A* and *B*, are flat rings properly grooved to receive the ends of the inner and outer casings, and secured in place by long bolts engaging suitable

nuts at top and bottom. While such a construction is probably unreliable for high pressure boilers of large power, it is able to withstand a working stress of 200 pounds in the steam gauge, and the development of a large horse power in proportion to the water capacity of the boiler.

For a steam omnibus driven by an engine capable of developing as high as twenty-four-horse power, such a boiler would have a total heating surface of sixty square feet, a grate surface of 1.95 square feet and weigh 200 pounds. The fuel used for such a service is coke, to be fed to the furnace through the centre of the

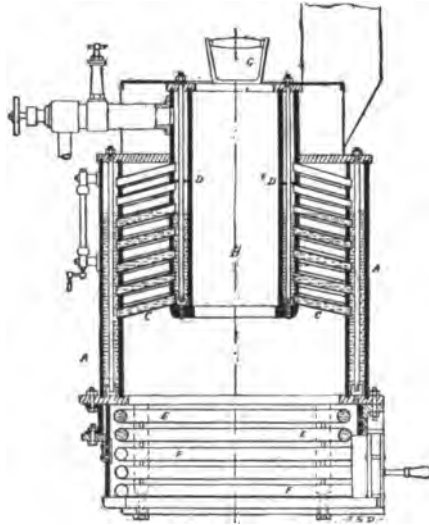

FIG. 160.—Familiar Form of the De Dion Boiler. A is the outer annular chamber connected to the inner annular chamber, B, by the inclined tubes, CC. A screen, DD, separates the steam and water spaces. EE are tubes for pre-heating the feed-water; FF, for superheating the exhaust steam. Steam connections same as in Fig. 157.

annular vessel, B, which is closed by the cover, G. As will be readily understood, the numerous connecting tubes, CC, serve the double office of promoting the water circulation and increasing the heating surface. The result is a very powerful and serviceable generator.

Other Heavy Vehicle Boilers.—There are several other heavy vehicle boilers which seek to combine the features of water-tube heating surface and improved circulation, among

which may be mentioned the Clarkson & Capel and the Weidknecht. Both these boilers are built on the water-jacket vertical design, shown in Fig. 123, except that the steam chamber over the fire is very much higher up in order to provide room for between fifty and eighty inclined tubes running between the two

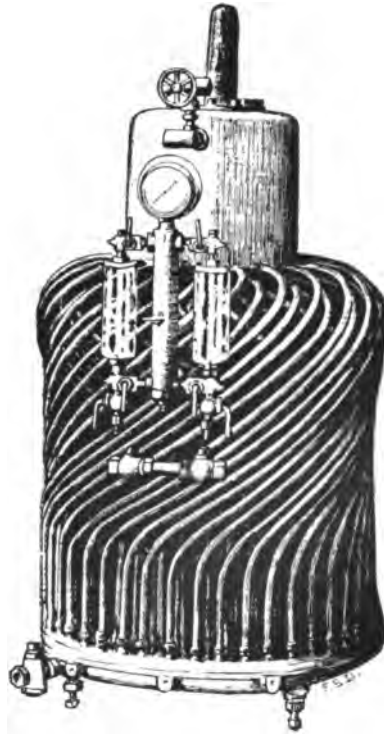

FIG. 170.—The "Lifu" Steam Boiler, showing arrangement and inclination of the tubes. The central steam drum terminates in two legs at the bottom, which are connected at either side to the annular mud-and-water drum at the base, thus completing the circulation.

sides of the water-jacket space, and across the draught. Above these in the Weidknecht generator are also a number of vertical smoke tubes, but in the Clarkson & Capel the space is occupied by a single chimney flue. One of the most elaborate attempts to utilize the water tubes to promote circulation is shown in the "Lifu" boiler, which is used on the wagons of the Liquid Fuel

Engineering Co., of England—the name of the boiler being derived from the first syllables of the first two words. Most of the general structural points may be understood from the figure, which shows three principal parts; a circular trunk tube at the base, from which a large number of curved tubes lead to the steam drum shown above. In addition to these the trunk tube is also connected to the bottom of the drum by a water connect-



FIG. 171.—Improved Rider Boiler. The same J-tubes are used in this generator as are shown in a former figure, except that, instead of being inserted into plugs, as there shown, they are expanded evenly into the crown sheet; thus giving a much larger heating surface. The feed water circulates through the coil surrounding the tube area, thus insuring its pre-heating. Rapid steaming qualities and very high efficiency are claimed for this type of generator, which can develop $6\frac{1}{4}$ horse-power on $16'' \times 16'$ dimensions, over all, and 5 horse-power on $14'' \times 14''$ dimensions.

ing arch, both legs of which are cast in one piece with it at opposite sides. This water arch makes the circulation complete along natural lines. The water tubes are connected to the trunk tube three deep and staggered. The connections are made by gun metal union nuts, the same kind of joints being used in joining to the copper steam drum. Each row of tubes, as shown, is

given a spiral bend around nearly one-third of the circumference of the drum, about nine inches from the base and in an opposite direction to the next row, so that complete water circulation is ensured in every direction. The whole structure is enveloped in an iron sheath and packed, and heat is supplied by the gas burner described later.

The Ofeldt Tubular Boiler.—Among the interesting types of tubular carriage boilers may be mentioned the Ofeldt generator, shown in the accompanying figures. As may be seen, it consists of an upright steam and water drum, having a somewhat

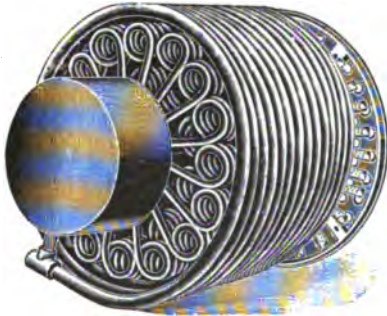

FIG. 172.



FIG. 173.

FIG. 172.—Top view of the Ofeldt boiler, showing the feed-water coil surrounding the generating coils : also attachments of generator coils.

FIG. 173.—Side elevation, showing steam chamber, generator coils and burner.

enlarged head, which serves as a steam chamber. Around this upright drum, and connected to it at top and bottom, are eighteen spirally-twisted steel tubes, which are directly exposed to the heat of the burner, and control the circulation of the water. The construction of these steel tubes permits considerable expansion in directions sidewise of the boiler; thus preventing the natural lengthening of the tubes under the heat of the burner from disturbing the connections at top and base. The burner of this boiler consists of a number of tubes, starting on radii from a central mixing drum, like the steam and water drum already described; each one having pin-hole perforations at the top for

the flame and being closed at the end. The vaporizing coil passes over several of the burner tubes.

As shown in the first figure, the feed water pipe is coiled around the entire generator, from top to base, thus ensuring a thoroughly heated supply of water in the central drum. The whole structure is sheathed in a sheet steel case.

According to the claims of the inventor, it is impossible to burn out this boiler, owing to the durability of the material and the security of the joints. He asserts that the water was exhausted from one of these boilers twenty times in succession, leaving the tubes exposed to the fierce heat of the burner until red hot. Water being then pumped in, no leaks were discovered, and steam was generated as usual. If these claims can be made good in practice, such a boiler should be useful in steam carriages, where every possible provision must be made against careless or incompetent handling.



FIG. 173A.—Elevation of the Ofeldt Tubular Boiler Encased in Sheathing, showing control valves and position of the smoke vent.

CHAPTER FOURTEEN.

FLASH STEAM GENERATORS.

Serpellet's Flash Boilers.—The first real impulse to the modern steam carriage was the invention by Léon Serpollet in 1889 of the famous "instantaneous generator," known by his name. It consisted of a coil of one and one-half inch lap-welded steel tubing flattened until the bore was of "almost capillary width"—this he later increased to about one-eighth inch—and this, sur-

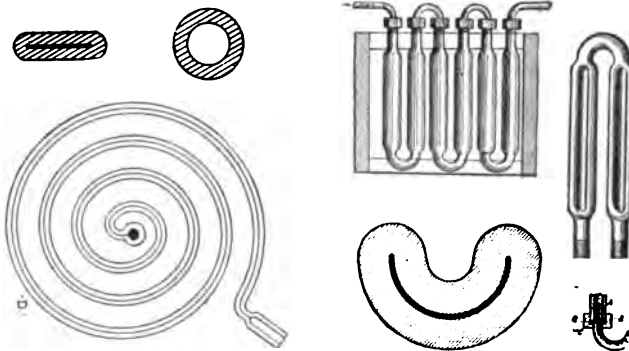

FIG. 174.

FIG. 175.

FIG. 174.—Earliest Form of the Serpollet Flash Generator ; a coil of flattened steel tubing.

FIG. 175.—Second Form of the Serpollet Flash Generator : a series of tubes pressed as shown, bent U-shape and nested ; the extremities being connected by joints and bent unions.

rounded by a cast-iron covering to protect the steel from corrosion by heat, was exposed to the fire. The result was an extremely rapid generation of steam, the coil being first heated, and the water being vaporized almost as soon as it was injected into the tube. Later, he improved the efficiency of his coil by corrugating its surface. With such a generator of 108 square inches of heating surface more than one boiler horse power could be developed, the average hourly evaporation being forty pounds of water. The usual working pressure was 300 pounds to the

square inch, but each tube could bear a test of as high as 1,500 pounds. One great advantage lay in the fact that the high velocity acquired by the steam and water in the narrow tube served to keep the surface thoroughly free from sediment and incrustations. For vehicles requiring an additional generative power two such coils were used, one above the other, the water being injected into the lower and the upper one serving to superheat

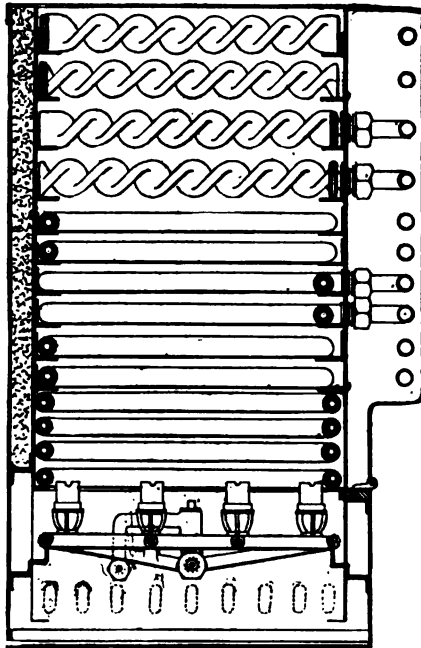

FIG. 176.—Later Form of the Serpollet Flash Generator, consisting of three layers of tubing. The four lowest tiers shown form a coil into which the feed water is injected; the second series of six tiers are arranged "zig-zag," like the nested tubes shown in Fig. 175; the third, or topmost, series of four tiers are also arranged "zig-zag," but are flattened and then twisted as shown.

the steam. To stop the engine it was necessary only to shut off the water feed pump, with the result of stopping the generation of steam at once.

In improved boilers of the Serpollet type a number of straight tubes were united by bent joints and nested, the several layers being connected in series. Moreover, each tube length was flat-

tened, so as to form a U-shape, or crescent, in its cross-section, which arrangement greatly increased its evaporating capacity. But the most efficient form was reached in the design shown in Fig 176, which shows three superposed sections of tubing; the lowest, four tiers of coil; the second, six tiers of "zig-zag," the

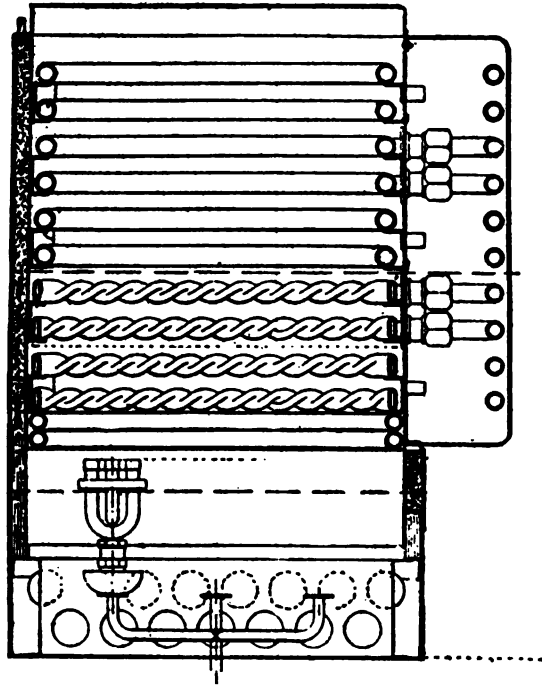

FIG. 177.—Recent Form of the Serpollet Flash Generator. In this type the twisted tubes are placed at the bottom and the "zig-zag" nested tubes at the top. The reason for this arrangement is that twisting the tubes affords a much larger heating surface; hence these tubes are directly exposed to the fire.

successive tiers being staggered, as shown; the third, several tiers of flattened tube twisted to angles of about forty-five degrees. The water is fed to the lowest section, which is immediately exposed to the fire, being thence passed to the second, whose available heating surface is of the greatest possible dimensions, and finally delivered, as superheated steam, from the upper-

most twisted coils. The several sections of tubing are connected together *in series* by bends and unions outside the case, as shown, and the entire generator is enclosed in a double sheet-iron casing packed with asbestos. By the arrangement of the tubing, as here shown, the full power of the heater, in both draught and radiated heat, is utilized, as in the type of boiler shown in Fig. 123, but the circulation of the water is perfectly under control and rapid generation of steam assured. For a six-horse power boiler of this type the outside dimensions, including heater space, are about $2\frac{1}{2} \times 1\frac{1}{2}$ feet, the total tube length, ninety-five feet, and the heating surface, about twenty-five square feet; giving a generator of convenient size for a four-seat road carriage.

Of Flash Generators in General.—Following along the lines of Serpollet's famous "flash" generator, with its numerous advantages in point of quick steam, high pressure capacity, freedom from scale deposits, and complete immunity from explosion, several designers of steam carriages and wagons have produced improved "boilers" of similar description. Serpollet's first generator, as applied to his light steam carriage of 1889, was merely a coil of flattened tubing. Later two such coils, connected in series, formed his generator, and finally the complicated trains of coils and bent tubing. In the latest generators described the water is fed to the lowest tier of tubing, and the steam is taken off at the top, as in the several types of coiled water-tubed boilers, already described.

The contrary procedure is followed in most of the really successful flash generators produced by other inventors. The Blaxton generator feeds from the lowest water coil, but the Simpson-Bodman, White, Automobile Manufacturing Co., and others feed from the top and superheat the steam in the lowest coils. This seems to be the most logical process for this type of generator, since, as the water is explosively vaporized by contact with the heated tubes, it follows that the progress should be from the lowest to the highest temperature, vaporizing and superheating the steam, rather than allowing it to follow a course from higher to lower temperature, with the accompanying consequence of loss of heat. By making the tubes of sufficient capacity to vaporize a good quantity of water, surprisingly high temperatures may be obtained in a short time and high power

engines may be driven with perfectly dry steam. In these particulars the flash generator is superior to a boiler of any type, although it is probable that its use for light carriage purposes will be very limited.

The White Flash "Boiler."—Among the light steam carriages equipped with flash generators may be mentioned those

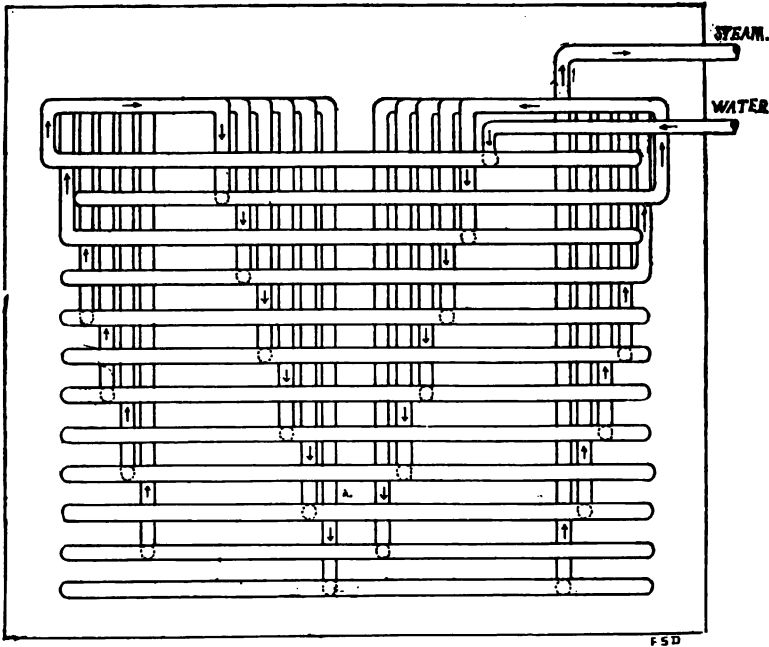

FIG. 178.—Diagram Illustrating Arrangement of the Vaporizing Coils of the White Flash Generator, Elevation. The water is fed into the centre of the top coil, flowing all around that coil and, in series, through every other coil in succession. It is "flashed" into steam somewhere above the lower coils, being taken off from the bottom one. The steam pipe rises to the top of the generator, as shown.

constructed by the White Sewing Machine Co., and the Automobile Manufacturing Co., the latter an English concern. The White generator consists of twelve superposed plane profile coils of quarter-inch seamless steel tubing, which are connected continuously from top to bottom. The water, under impulse from a

plunger pump operated from the crosshead of the engine, as in most steam carriages, enters the top coil at the centre point, flowing thence around the tube to the outer extremity of the coil and over again to the centre of the coil next below. The same connection of outer and centre extremities is maintained throughout the entire series of coils until the bottom one is reached. Here the connection of the outer extremity is to the top of the generator case, where is the steam out-take. This arrangement may be readily understood on examining the diagram.

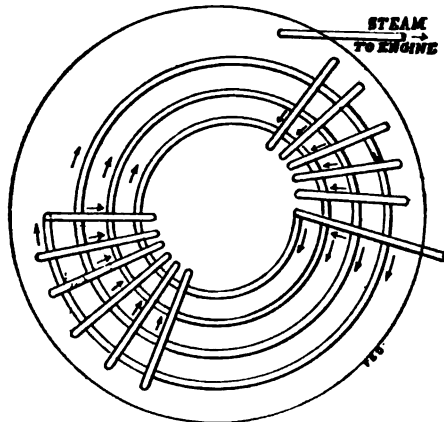

FIG. 179.—Plan of the White Flash Generator, showing top coil, with water and steam pipes, also connections between the successive coils.

The water, pumped into the top coil, passes entirely around, and thence through each coil continuously, until the bottom coil is reached. Somewhere in the downward travel it becomes vaporized, and by the time it emerges from the last coil it has become superheated steam. The amount of water actually fed to the coils is determined by a diaphragm regulator, which controls a by-pass valve, operating to return any surplus feed to the tank. The feed is thus interrupted when the pressure falls—which fact indicates the presence of too much water in the tubes, since the amount of contained water and the total pressure per square inch are in inverse proportion. By this means the operation of the generator may be maintained automatically at a uniform point; its output efficiency and the rapidity of steam generation being

dependent on the amount of fuel consumed by the burner, which fact determines the heat of the coils.

The pressure is indicated by an ordinary steam gauge, which shows a normal working pressure of 200 pounds per square inch, that being the point at which the tension of the regulator spring is adjusted. The safety valve, however, is adjusted to blow off at 500 pounds, a pressure which the coils are said to be able to

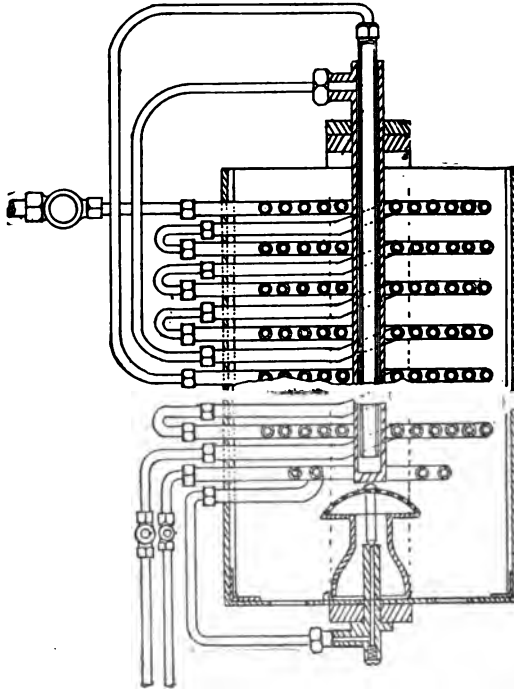

FIG. 180.—Sectional Elevation of the Blaxton Flash Generator.

withstand. Under usual conditions of operation the steam may be superheated to about 800 degrees. As in all flash generators, no water is fed to the coils when the engine is not working, and the first essential act in starting work is to begin feeding by hand, which it is necessary to do no longer than to provide for the generation of steam for the engine. The generator is of the usual size of light carriage boiler, when encased in its sheet iron and asbestos packing cover, and runs a 6 horse-power engine.

The Blaxton Flash Generator.—The Blaxton generator, although differing in several important particulars, is constructed on the same general theory, consisting of a number of superposed plane-profile coils of tubing, through which the water is passed in series, from the lowest coil to the top, where it is taken off as steam. As shown in the figure, the water fed from the pump passes direct to the centre of the lowest coil, thence around to the outer extremity, and to the centre of the second coil. The connections between the coils of tubing are made by nut joints and unions outside the casing. The feed water is pumped in by hand until sufficient steam to operate the engine is obtained, precisely as in other flash generators.

The particularly interesting feature of the Blaxton generator is the device employed for automatically maintaining the consumption of fuel and of steam at one ratio. As shown in the diagram, the fuel oil is pumped into the short coil placed lowest in the case, and, being vaporized by the flame, passes around to the burner. Directly above, and nearly touching, the burner is a vertical tube, closed at the lower end and containing a second somewhat shorter tube.

The water, in process of vaporization, passes from the outer extremity of one of the coiled elements directly into the inner of these two tubes, the circulation being completed when it passes up between the inner and outer tubes, through a joint, into the centre of the coil next above. By this means the temperature, and consequently the length, of the outer tube is regulated. For, so long as the feeding of cold water continues, the water or steam, passing through this tube, absorbs a large percentage of its heat, thus preventing unusual expansion lengthwise, but, when the supply is cut off, or when, from any cause, the heat becomes too great, the tube elongates, and, pressing down upon the gland of the burner, closes the needle valve that controls the fuel supply. By this means the life and usefulness of the generator is prolonged, as much as possible, since overheating is prevented by the constant closing of the fuel feed valve. The Blaxton generator is thus rendered more highly efficient than most of the average "flash boilers," whose greatest drawback is the constant tendency to burn out, if left long exposed to heat when no water is being fed to the coils.

The generator herewith illustrated measures 5 feet 9 inches in

height and is 3 feet square. It contains 126 square feet of heating surface, has a normal working pressure of 200 pounds per square inch, and can propel an engine of 25 horse-power. This average on heating surface is about equivalent to that of a good water-tube boiler, although here steaming is more rapid.

The flash generator of the Automobile Manufacturing Co., although operating on precisely similar principles, consists of seven pairs of spiral tubes, each pair connected at the bottom by suitable socket joints, and having their upper ends communi-

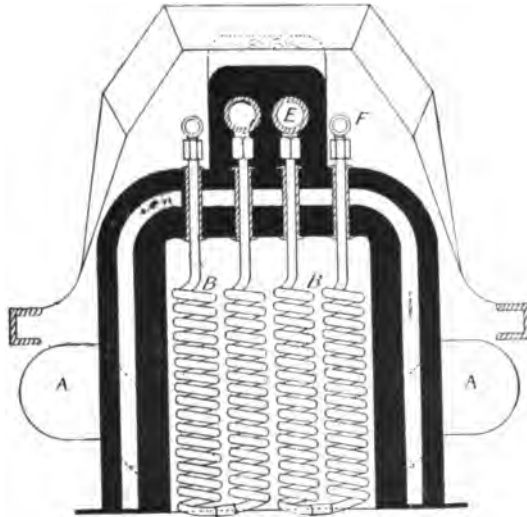

FIG. 181.—Front Elevation of the Flash Generator of the Automobile Manufacturing Co., of England. A A are spaces for side draughts; B B, flash tubes; E, steam chamber; F, water feed pipes. The whole is covered by such a "bonnet" as is familiar on large gasoline cars.

cating, respectively, with the water and steam feed pipes. The eighth pair of spiral tubes is constructed in precisely the same manner, but being intended for vaporizing the fuel oil, has the two upper ends of the tubes connecting, respectively, with the oil tank and the burner. Water is fed to the top of one of the tubes of each pair, and, being vaporized before the bottom of the tortuous channel is reached, is given off as superheated steam at the top of the opposite tube. As may be readily understood from examination of the figure, the same end is attained with the

use of such spiral tubes, as by a number of superposed coils. The injected water is exposed to an extensive surface, heated to a high temperature, and is subjected to its action for a sufficiently long period to become thoroughly vaporized and superheated. Each such double tube in the carriages of this company is about 24 feet, which gives a total length for 7 tubes of 168 feet, and with a $\frac{3}{4}$ -inch diameter, a total heating surface of about 126 feet.

The Simpson-Bodman Flash Generator.—The Simpson-Bodman flash generator is probably the best known after that of Ser-

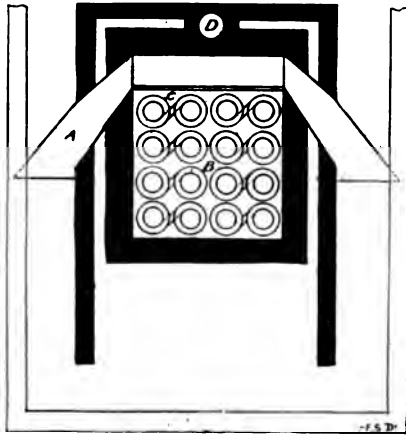

FIG. 182.—Plan of the Flash Generator of the Automobile Manufacturing Co., of England. B, the steam generating tubes; C, the fuel-vaporizing tubes; D, the smoke vent; A, the side draughts.

pollet, although its use on motor vehicles is confined to the heavy tractors and lorries built by the firm. Briefly, it consists of a number of tiers of bent tubing connected in series with the form of connector, known as the Haythorn joint, very much after the manner of Serpollet's later generators. Unlike Serpollet's tubes, however, the portions here exposed to heat are not flattened or twisted, but indented, as shown in an accompanying figure, after the manner of the Rowe tube, so called from the inventor of the process. The tubes are also of larger diameter and thicker walls than those used by Serpollet, and, according to the claims of the manufacturers, can withstand a test pressure of one ton (2,240 lbs.) to the square inch.

With a generator of this description consisting of twelve two-legged elements, or double tubes, each leg indented through a length of 2 feet 6 inches, $3\frac{1}{2}$ -inch pitch of indent—which gives a total heating surface of 46 square feet—and a grate area of $2\frac{1}{4}$ square feet, an efficient temperature of 400 degrees, Fahrenheit, has been obtained in 25 minutes from kindling the fire, and a working pressure of at least 250 pounds per square inch in 30 minutes. In fact, it is necessary, with this generator, to provide

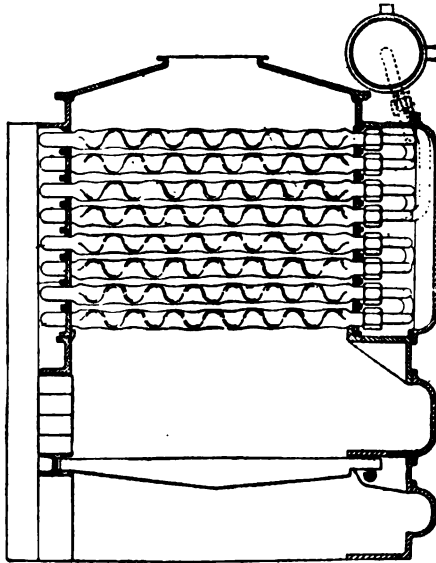

FIG. 183.—Sectional Elevation of one Form of the Simpson-Bodman Flash Generator and Casing, showing the steam drum at the right top of the casing, through which the feed water is pumped to the indented "Row" tubes, bent double, arranged "zig-zag" and nested, like the tubes of the Serpollet generator shown in Figs. 175, 176, 177. The connections between the tubes outside the casing are by U-connectors and Haythorn joints.

against too high a temperature of steam—it is not unusual under running conditions that it reach a temperature of 1,000 degrees, Fahrenheit, which would, of course, decompose the lubricating oil, if admitted to the cylinder. Consequently, an essential feature of construction is the steam drum, which is an elongated cylinder containing one or two U-shaped tubes. The steam is let into this drum, and the feed water on its way to the top

coil, passes through the U-shaped tubes, thereby absorbing a goodly proportion of the superfluous heat. On leaving the drum, therefore, the steam has reached a temperature sufficiently low to be fed to the engine.

Instead of using any device for regulating the heat, or opening the by-pass valve, a back-pressure valve is fixed on the feed pipe between the by-pass and the generator, which, it is said,

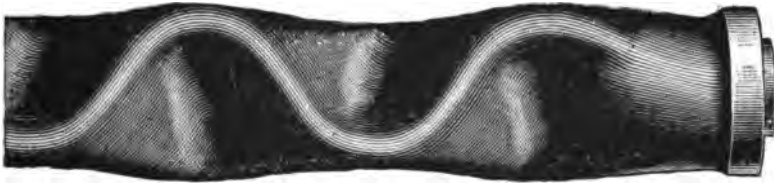

FIG. 184.—Length of "Row" tube, such as is used on the Simpson-Bodman generator for producing an enlarged heating surface. This cut shows the manner of making the indentations.

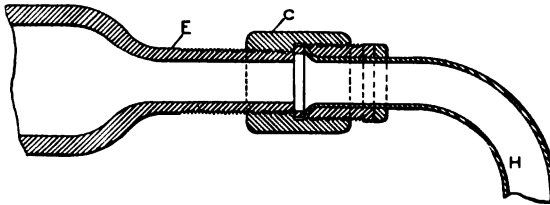

FIG. 185.—Diagram of the Haythorn joint used on the Simpson-Bodman and other flash generators.

furnishes a much more economical means of dealing with over-supply of water than that of returning it to the tank. The steam is allowed to collect in the drum, and superfluous pressure is relieved by an ordinary safety valve loaded fairly high. This insures a ready supply of steam on hand to start the engine, instead of resorting to the usual method of pumping in water with a hand pump.

CHAPTER FIFTEEN.

BOILER FEEDERS AND WATER LEVEL REGULATORS.

Of Boiler Feeders in General.—There are two different kinds of device for feeding water to steam boilers: plunger pumps operated by the engine or by a separate cylinder; and injectors, which raise and feed the water by a steam jet from the boiler itself. Injectors are largely used for locomotive, marine and stationary boilers, but to the present time almost not at all in steam road carriages. The principal reason for this is that the valves and apertures in an injector, suited for a light carriage boiler, would have to be made so small that they would be constantly clogged with dirt and sediment, hence rendering the instrument inoperative. Furthermore, when in operation, an injector would be liable to fill the boiler too rapidly, while the pressure remained sufficient to raise the water, thus causing priming; and, if shut off until the water level had fallen considerably, would cause damage to the boiler by flooding it, while in an overheated condition. One or two successful steam carriages, as, for example, the McKay carriage, use an injector as supplementary to the plunger pump, which, as in many other carriages, is operated from the crosshead of the engine. It is used, however, only when the plunger pump is disabled and cannot supply enough water, or when it is desirable to replenish the water tank from some wayside source. If, as has been occasionally suggested, an injector of sufficient proportions to be proof against most small obstructions be used, in connection with some kind of automatic device for opening the by-pass valve back to the water tank, whenever necessary, a larger amount of steam would probably be required to operate it than could be very well spared. These are a few reasons why injectors on small carriage boilers are very undesirable.

The Injector: Its Theory and Operation.—The theory and operation of the boiler feed-water injector may be understood from the familiar diagram shown in an accompanying figure. Here, as may be seen, steam from the boiler, *A*, is let through

the pipe, *B*, into a closed nozzle, *E*, communicating with a water tank by a siphon tube, *C*, causing the air to be exhausted in *C*, and the water to rise into *E*. By the same impulse the water thus raised is forced through the tube, *F*, into the boiler, so long as the cock, *G*, remains open. When it is closed, the steam should find an outlet only through the pipe, *C*, into the water tank below. On this general plan a great variety of injectors has been based, some of them, particularly such as are used on railroad locomotives, being very complicated in construction. A fairly typical variety of injector, shown herewith, may be readily understood from the foregoing description. Here, *M* is the stem of the steam valve, which is controlled by the handle, *K*, so that

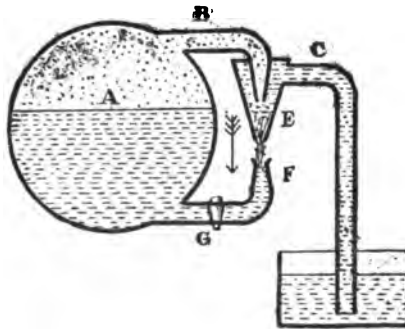

FIG. 186.—Diagram Illustrating the Operation of a Boiler-Feeding Injector. *A* is the boiler; *B*, a pipe leading steam to the nozzle of the injector; *C*, a pipe leading from the feed tank; *E*, the nozzle, through which the steam forces the water raised; *F*, the feed pipe leading to the boiler; *G*, a control cock.

the amount of steam used may be controlled, as desired. The water entering at the opposite side, as shown, is forced by the steam passing through the nozzle, *S*, into the tube, *V*, going thence through the tube, *CD*, to the boiler. The steam, given off during the passage of the water through *V*, *C* and *D*, escapes through the overflow valve, *P*, around the body of the instrument and out, as shown by the arrow. If now, valves in the pipes leading to the boiler and the overflow be closed, the steam entering through *S* finds an outlet only through the water-feed pipe, being thus forced into the water tank, as is often done for the purpose of thawing it out in cold weather.

Plunger Pumps and By-Pass Valves.—As above stated, the plunger pumps used to feed steam carriage boilers are most often operated from the cross-head of the engine. Consequently, so long as the engine is in motion, water is steadily pumped into the boiler. When, as shown by the water glass, the level is too high, the by-pass valve may be opened, and the water pumped from and back again to the tank. In some carriages the by-pass is always operated by hand; in others it is controlled by some kind of automatic arrangement, such as will presently be de-

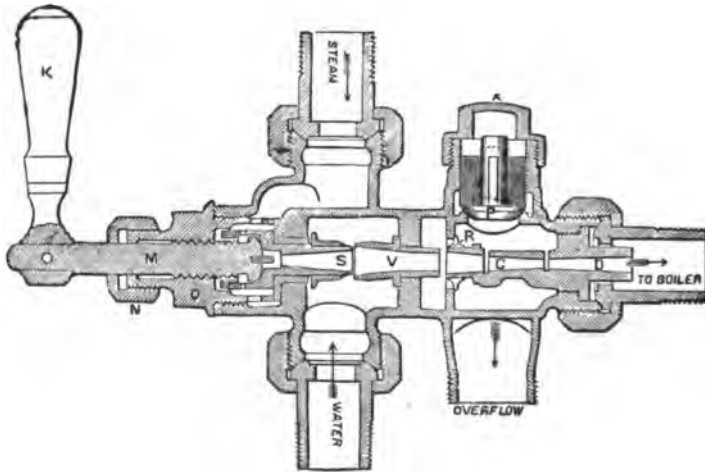

FIG. 187.—Construction of one Type of Injector. S, steam jet; V, suction jet; C-D, combining and delivery tube; R, ring or auxiliary check; P, overflow valve; O, steam plug; M, steam valve and stem; N, packing nut; K, steam valve handle; X, overflow cap.

scribed. The automatic control of the by-pass is extremely desirable, particularly since unskilled engineers most often have charge of carriages and are exceedingly liable to forget the small details of management. On the other hand, many automatic devices get out of order altogether too easily, and leave the carriage driver to exercise his skill and judgment at an unexpected moment.

In addition to the danger of flooding the boiler, the opposite embarrassment often occurs—owing to some disarrangement, the pump may fail to feed enough water to the boiler, or may not

operate at all. Then it is necessary to use a supplementary feeder, which is either a hand pump, an injector, as used on the McKay carriage, or a steam pump operated by a separate cylinder, as in the Victor carriage, about to be described. Such supplementary steam pumps and injectors are commonly arranged to start automatically, as required, but may also be started by a hand-controlled valve. Another advantage involved in the use of automatically controlled steam pumps is that water may be fed, as required, to the boiler, after the engine has ceased motion, and it is desirable to leave the carriage standing with steam up. In this condition, however, a very small amount of water is needed, except under unusual conditions.

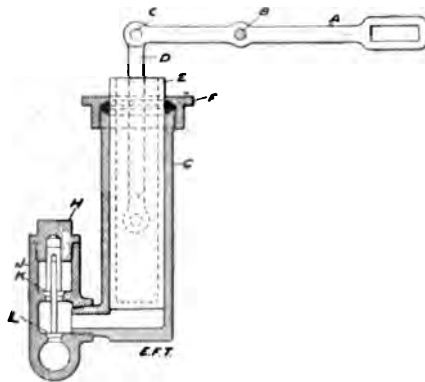

FIG. 188.—Section of a Type of Plunger Feed Pump. As is obvious, the valve opened by suction of the up-stroke is closed by compression of the down-stroke, and *vice versa*. This pump is equipped with a double, or compound, valve, which, as may be seen, secures perfect balance in operation with the simplest possible constructions. The stem of the suction valve enters a bore in the stem of the outlet valve. Referring to the lettered parts: A is the pivoted lever working the pump from the crosshead of the engine; B, the fulcrum point; C, the attachment of the piston rod; D; E, the trunk plunger; F, the packing cap; G, the pump cylinder; H, nut on the valve chamber port; J, the valve chamber; K, water outlet valve; L, water inlet valve.

Operating the By-Pass Valve.—In several well-known makes of steam carriage the driver is required to constantly watch the water glass in order to inform himself as to the water level in the boiler. On noticing that the level is too high, or is rising too rapidly—the proper level is generally about two-thirds up the glass—he opens the by-pass valve by turning a small-wheel placed near the throttle lever beside his seat. This act, as already

suggested, turns the water forced by the pump back again into the feed tank, a three-way cock controlling its travel. It would be highly undesirable to further complicate the machinery and the difficulty of operating the carriage by any device for disconnecting the pump under such conditions, as it is likely that, in the majority of cases, trouble would result. The simple turn of a valve wheel relieves the boiler without interfering with the delicately constructed mechanism.

If, after the water has been led from the boiler for some time, the level begins to sink, it is necessary only to close the by-pass



FIG. 189.

FIG. 189.—Folding Pail used for filling the Feed Water Tank.



FIG. 190.

FIG. 190.—Siphon for drawing Water from Wayside Source by Boiler Steam.

valve, thus resuming the feed. If, from any cause, the pump seems unable to keep up the water level in the boiler, and the reading of the water glass is verified by the try-cocks, thus showing that it is working perfectly and is unclogged with sediment, a few strokes of the auxiliary hand pump will suffice, if no injector or automatic steam pump be attached to the carriage.

Troubles With the Pump.—Since the small water pumps attached to steam carriages are of the simple plunger type, such as is used on fire engines, failure to supply sufficient water to the

boiler may generally be attributed to loosened packings or to clogged check valves. The rapid sinking of the level in the water glass will indicate trouble with the pump, except when ascending a high hill. In the latter case the fall of level may reasonably be attributed to the unusual steam consumption. Under usual circumstances, the trouble is due to loosened packings, and this trouble may be remedied by inserting new packings, although particular care should be exercised, so as not to pack the plunger too tightly and cause breakage. If it seems evident that the falling water level is due to clogged check valves—this is a comparatively rare occurrence—the fire should at once be extinguished and the check valves opened and cleaned.

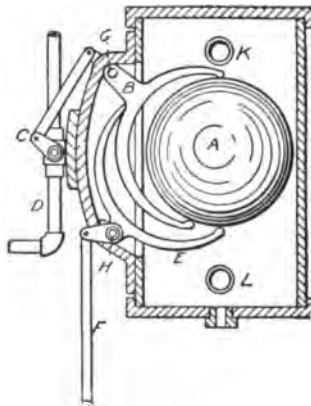

FIG. 191.—The Keene Automatic Water Level Regulator. The ball, A, floating in the water at boiler level; B and E contact fingers, or pivots; G and H, operating the valve, C, on water pipe, D, and the fuel valve through the link, F.

Automatic By-Pass Valves: The Keene Valve.—One of the most ingenious things in the way of an automatic control for the by-pass valve is the device formerly used in the Keene steam carriage, which is shown in section herewith. It is, briefly, a cylindrical vessel, communicating at the bottom with the water space and at the top with the steam space of the boiler, after the manner of the glass gauge, already described. Within this cylinder is a hollow metal ball, which, floating on the surface of the water, rises and falls with it, and when at a level unusually low or unusually high actuating one or another of two pairs of

finger contacts, as shown. When the water level is too high the ball rises, and, moving the upper finger, operates a lever to open the by-pass valve, thus shutting the water inflow from the boiler. When, on the other hand, the water level sinks unduly, the ball presses down the lower finger lever, thus shutting off the gas-line supply from the burner.

Such a device should be a very efficient protective to the boiler so long as the hollow metal sphere did not leak, but it must be carefully constructed, so as to avoid the disarrangements and premature operation in ascending steep grades, which is a fertile source of trouble with some makes of low water alarm using hollow metal floats. It was probably some such troubles as these that led to its disuse.

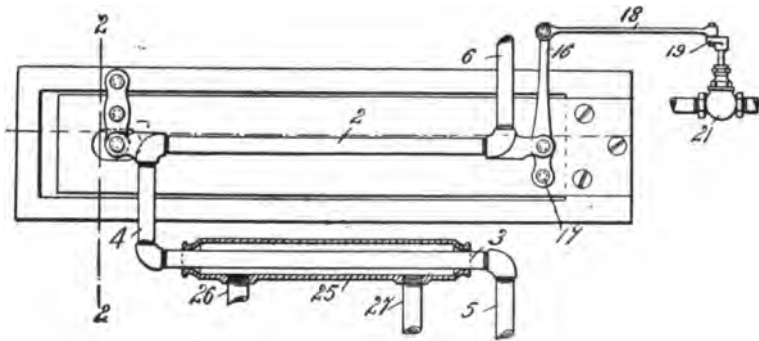

FIG. 192.—The Bullard Thermostat Regulator as arranged for a Stationary Boiler. The U-shaped tube, 2, 3, 4, the lower leg of which passes through the water-feed pipe, 25, is set at the normal water level, as indicated by the broken line above the upper leg. When the boiler level sinks unusually, the pipe elongates on its bed plate as far as the vertical line, 2, 3, thus operating the lever, 16, and closing the by-pass valve, 20, through the link, 18. The construction used on the "Victor" carriage is substantially the same as here shown.

The Thermostat Regulator.—The Bullard thermostat regulator used on the Victor carriage is quite as effective as the device just described, and probably considerably more durable. It consists of a tube bent U-shaped, and laid on its side, one end of it being in communication with the steam space of the boiler, the other with the water space, just below the normal water level. When the water in the boiler is at the proper level the lower half of the tube is filled with water to the bend. When the water level in the boiler falls, the U-tube is, of course, filled with steam

throughout its entire length, which fact involves that it lengthen slightly under the influence of the heat. On the restoration of the proper level in the boiler the effect of contraction of the tube is assured by a water jacket on its lower leg, consisting of a section of the feed-water tube between the water tank and the pump. The alternate lengthenings and shortenings of the tube, under variations of temperature, are efficient in actuating a lever, geared to an arm secured at the bend on the upper leg to the U-tube, thus effecting the closing or opening of the by-pass valve, and regulating the feed supply to the boiler. The movement of the lever under this pressure is only about 1-16 inch in either direction, but by virtue of a spring connection at the by-pass it is increased about four times ($\frac{1}{4}$ inch), which is a movement amply sufficient for operating the valve.

This device is at once simple and comparatively certain in operation, depending entirely upon the physical properties of the metal, which cause it to expand under heat and contract with a lower temperature. Several steam carriages use thermostat regulators to control the by-pass as well as to regulate the supply of liquid gasoline to the burner. A very interesting example of the latter type will be described in the chapter on burners. As seen already in the Blaxton flash generator a tube arranged to vary in length with the "dry" temperature is used to regulate the supply of oil in the burner.

Gravity Boiler Feeder.—An interesting device for maintaining proper water level in a boiler by means of gravity is found in the King boiler feeder shown in accompanying diagrams. This machine, which has been in actual use on a steam carriage, is contrived so as to dispense entirely with the plunger pump and all the valves and attachments necessarily used with it. Briefly, it consists, as shown, of a slightly tapering cylindrical shell, within which fits, water-tight, a similarly shaped chamber, the latter being rocked or turned by a lever, which is attached to a stem passing through a stuffing box at one end of the shell. This lever, or arm, is geared to a link bar, which transmits motion from the engine, so that the rocking movement or half rotation of the chamber is constantly maintained. Further, the outer shell has four openings, as shown; one to admit the feed water, flowing by gravity from the

tank ; the second to admit steam from the boiler ; the third communicating with the water space of the boiler ; and a fourth fitted with a check valve opening to the atmosphere. The inner chamber has at least three ports, or openings, so arranged as to accomplish the functions about to be described.

When the link and lever have brought the inner chamber into the position shown in the cuts, water flows by gravity from the tank through the tube connections at the top of the shell, completely filling the chamber. At the same time any air or steam in the chamber is let out through the ball check valve, also at the top of the shell. A half turn of the lever then brings the ports into communication with the steam and water spaces of the boiler,

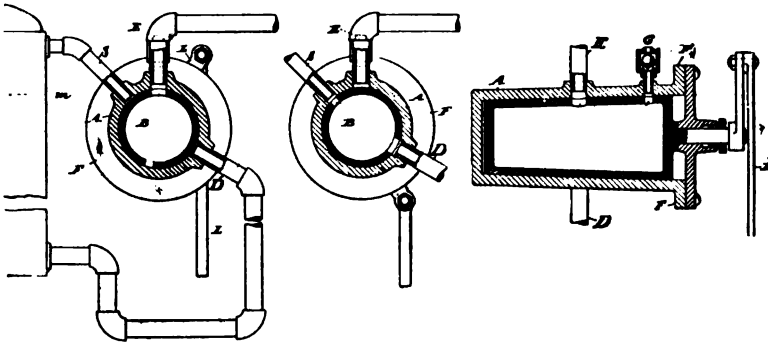

FIG. 193.—The King Gravity Boiler Feeder and Level Regulator.

allowing such water as may be needed to restore the proper level to flow in, under steam pressure and gravity. These operations are continuously repeated, and, so long as the supply of water in the tank is maintained, the level in the boiler is not allowed to fall. If the feeder is of sufficient size, and is placed at such a level as will involve that the water level in the boiler is lower than the highest point of the chamber and higher than the lowest point, the end of securing a steady feed will be attained.

The diagrams show that the supply pipe, between the outer shell of the feeder and the water space of the boiler, drops below the point where it enters the boiler. This is an essential feature of the mechanism, and is intended to prevent the transmission of

an excessive degree of heat from the boiler to the feeder chamber. The temperature of the water within the chamber should always be maintained well below the evaporating point in order to avoid such back pressure as would neutralize the very ends desired.

If such a machine as this be of proper proportions for the boiler it is designed to feed, and its position relative to the water level be adjusted, there should be no excessive waste of steam nor any great danger of injecting lubricating oil with the feed water. Its simplicity is a point in its favor, but, like all small slide valve devices, it would be rapidly disabled should it be allowed to grind very much.

Merits of Gravity Boiler Feeders.—As a general rule, it may be asserted, devices for feeding a boiler by gravity are unsuitable for steam carriages on account of the amount of vertical space necessarily occupied. Where it is possible to use some siphon arrangement there must be constant trouble and uncertainty, as the tank level sinks. Among the numerous objectionable gravity feed devices for steam vehicles, we may mention a recently patented invention which proposes to suspend the feed tank on springs capable of contracting and raising it as the water level sinks. It also specifies a cork float in the feed tank above which steam is admitted from the boiler, in order to assist the work of maintaining the water level through another tube at the bottom, communicating with the water space of the boiler, while, at the same time, preventing the cool tank water from interfering with the generation of a proper pressure in the boiler. Such a device would involve considerable waste of steam in a small boiler, and would be uncertain in operation under the vibrations of travel.

Flash Boiler Feeders: The Serpollet System.—The feeding apparatus for shell and water tube boilers is to be adjusted, either automatically or by hand, solely with reference to the maintenance of a proper water level. Thus, by far the greater number of automatic regulating devices depend for their operation on gravity or on some arrangement of floats within a closed chamber. Some moderately typical devices have been described to give the reader a good idea of the general problems involved in such constructions. With the feeding of flash generators,

however, the operation of automatic devices depends solely upon maintaining a certain predetermined pressure and temperature, which are properly in ratio to the quantity of water being vaporized in the tubes, as is not necessarily the case with generators of other types. It is possible, therefore, to maintain the feed at the proper rate and quantity by automatic pressure regulators, such as are used in connection with steam carriage burners, or else by some system of uniform regulation for fuel and water pumps.

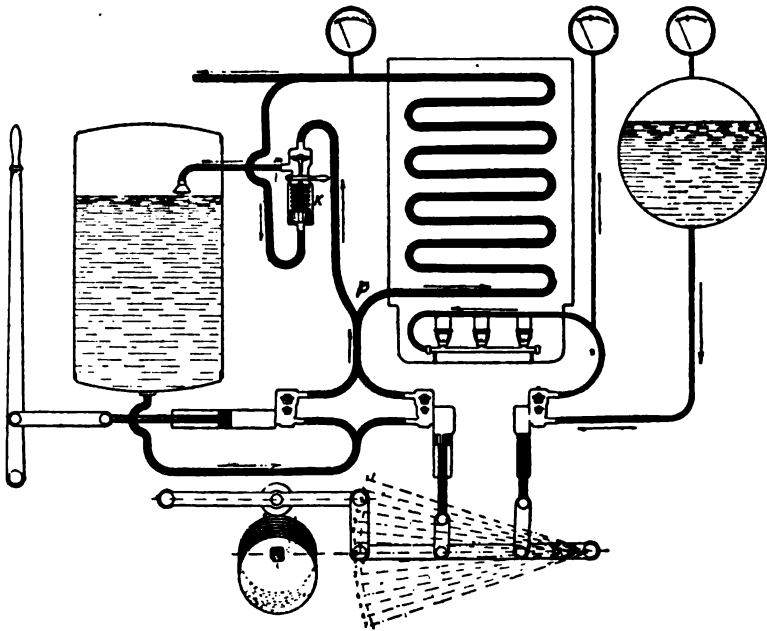

FIG. 194.—The Serpollet Water and Fuel Feed System. The method of hanging the stepped cam controlling the pump strokes may be here understood.

The latter theory is adopted in the Gardner-Serpollet system of fuel and water feeding for their flash generator, already described. As shown in the diagram, the fuel is fed to the burner, and the water to the boiler, through pumps, both of which are operated from the same shaft. The fuel pump is smaller than the water pump and its stroke is also shorter, as is obviously necessary, but as is evident from the diagram of the pump connections,

also shown, its stroke would always be in the same proportion to that of the water pump, if by any means the stroke of the vibrating lever, to which both pistons are connected, could be varied. This end is, in fact, accomplished by the use of a stepped cam, consisting of a row of eccentric discs, of varying eccentricity, which, placed upon the rotating shaft, may be slid in either direction, thus varying the lift and drop of the lever bearing the roller shown, and actuating the first lever through the link bar connecting the two. By shifting the cam inward toward the driving

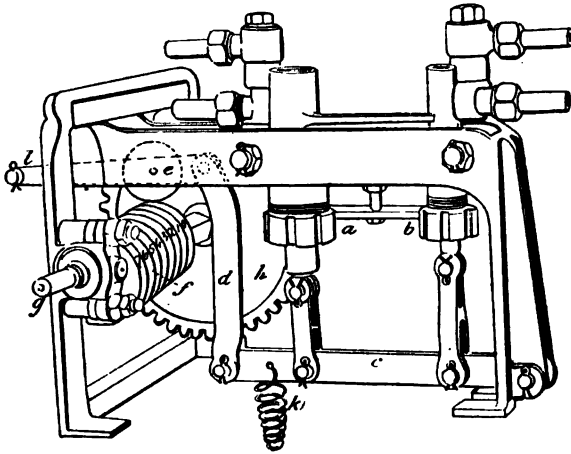

FIG. 105.—Serpollet's Fuel and Water Pumps. The water pump, *a*, and the fuel pump, *b*, are operated from the lever, *c*. This is given an up-and-down movement by the link, *d*, whose stroke is varied by the stepped cam, *f*, on which bears the roller, *e*, on the rod pivoted at *i*. The rotary movement of the cam shaft, *g*, is imparted by the spur wheel, *h*.

spur the strokes of both oil and water pumps may be varied from zero to maximum; the cam surface being efficient in giving a greater or shorter inward stroke, and in permitting an outward stroke of equal length under stress of the spiral spring attached below the pump operating lever.

The liquid fuel and the water, being thus varied in the amounts given forth by the pumps, are forced, the one into the vaporizing tube, shown as passing over the burner, the other into the flattened and nested tubes of the generator, which are directly exposed to the heat of the flame. By this means the heat is increased in ratio with the quantity of water injected, and the

working pressure may be regulated to any desired limit. When, however, the pressure has risen above a certain fixed point—it is generally fixed at about 355 pounds per square inch—it is able to open the spring safety valve, shown attached to the steam pipe, thus also opening the by-pass, so that the water from the feed pump is thrown back into the tank. The water from the pump may be forced through the spring valve, instead of into the generator, by the closing of a check valve at *P*, under steam

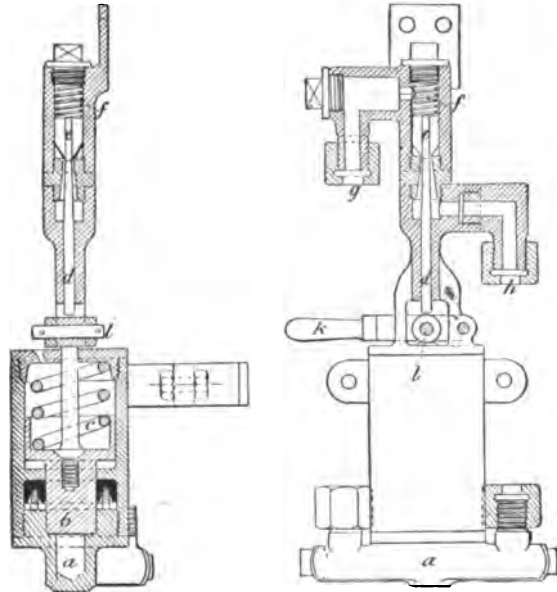
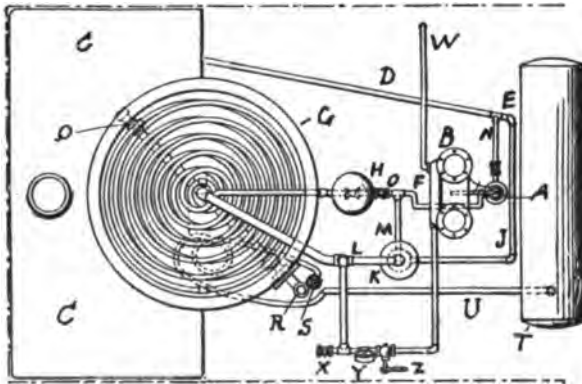
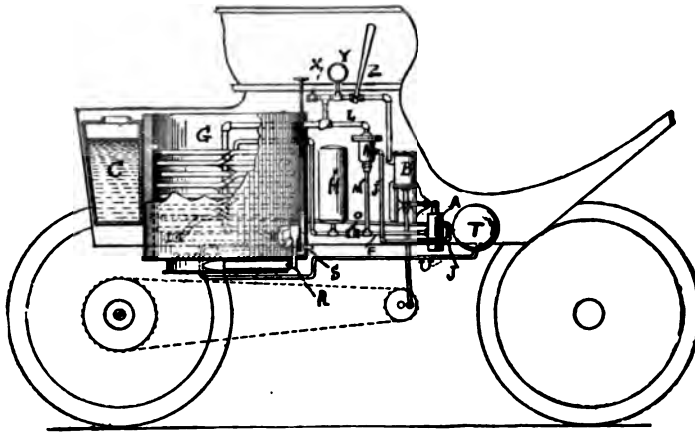

FIG. 196.—The "Safety Valve," or Automatic By-Pass Regulator of the Serpollet Boiler Feed System. The steam, admitted through the tube, *a*, after it has reached a certain pressure, opens the valve, *b*, compressing the spring, *c*. By this action the rod, *d*, forces up the valve, *e*, and the spring, *f*, thus enabling the water from the pump to pass from the pipe, *g*, through the pipe, *h*, to the water tank.

pressure. The connections may be readily understood from the diagram, which also shows a hand operated pump for making the initial injection of water into the generator tubes previous to starting the engine.

The White Flash Boiler Feed System.—The water-feed system of the White steam carriage flash generator is based on a different theory, although the by-pass valve is controlled by a



FIGS. 197-198.—Diagrams of the Fuel and Water Feed System of the White Steam Carriage. A is the water pump operated from the cross-head of the engine, B. C is the water tank; D, a pipe leading to the pump, and branching off at E, as shown, into J and N. F is the boiler feed pipe leading through the check valve, O, and the air chamber, H. K is the automatic by-pass regulator; L, a pipe leading steam from the generator, G, and allowing the water to circulate through F M K J E N A, whenever steam pressure rises high. X, the pop valve; Y, the gauge; Z, the throttle; T, the fuel tank; U, the fuel feed pipe; Q R S, the fuel regulating and vaporizing system explained later.

spring and pressure device, as with Serpollet. The details of the system may be understood from the accompanying diagrams, which exhibit all the essential features. A plunger pump, *A*, operated by a pivoted lever from the crosshead of the engine, *B*, forces water from the tank, *C*, through the pipe, *D*, which, how-

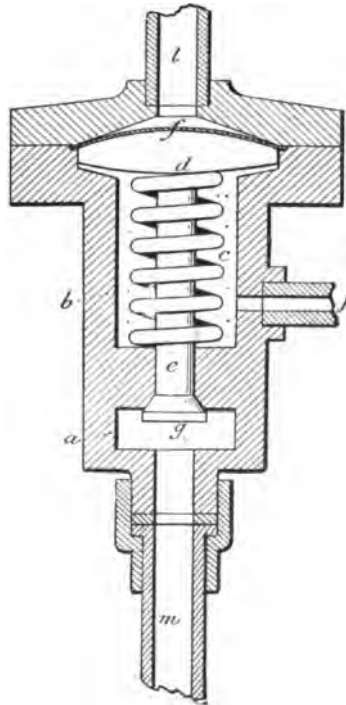

FIG. 199.—Section of the Automatic Boiler Feed Regulator of the White Steam Carriage. Steam entering at the port, *l*, bears on the diaphragm, *f*, and the head, *d*. When its pressure is sufficient, it opens the valve, *g*, on the rod, *e*, by compressing the spring, *c*. This operation opens communication between the chambers, *a* and *b*, allowing the water fed by the pump over the pipe, *M*, to enter at the port, *m*, and circulate thence through valve, *g*, chamber, *a*, port, *J*, and over the pipes, *JEN*, back again to the pump, *A*. The valve rod, *e*, should have a greater clearance than is shown in this cut.

ever, divides into two branches at the point, *E*, one portion of the water being forced by the pump through the pipe, *F*, to the coils of the generator, *G*. The pipe, *F*, has the air-chamber, *H*, located, as shown, between the pump and the steam generator. Another portion of the water coming through the pipe, *D*, passes

through the pipe, *J*, which communicates with the lower chamber of the pressure regulator, *K*, to be described later. Since the regulator, *K*, is operated only when the steam pressure has reached a certain predetermined point, when the by-pass valve is opened, the pipes, *F* and *J*, are not in communication so long as the pump, *A*, operates to feed water to the coils of the generator, *G*.

The regulator, *K*, is constructed and operated as shown in an accompanying diagram. It consists of two chambers, *a* and *b*, which are put into communication on the opening of the valve, *c*, normally closed by the spiral spring, *d*. The rod carrying the valve, *c*, is attached at its opposite end to the head, *e*, which bears against the metal diaphragm, *f*, held between the casing of *a* and *b* and the cap, *g*. The operation is obvious. The port, *l*, shown just above the diaphragm, *f*, is connected direct to the generator by the pipe, *L*. When, therefore, the steam pressure has risen above a certain predetermined point, which means that a greater force is exerted on the upper face of the diaphragm, *f*, than comes through the head, *e*, from the spring, *d*, the valve, *c*, is opened, making free communication between the chambers, *a* and *b*. Since, now, the ports, *j* and *m*, are on the pipes, *J* and *M*, which are connected in the system, as shown, the opening of the valve, *C*, means that the water circulation from the pump, *A*, is through the pipes, *F*, *M*, *J*, *N*; all water being shut from the coils of the generator by steam pressure at the check valve, *O*. So soon soever as the steam pressure again falls to normal, the valve, *c*, is closed by the spring, *d*, and the check valve, *O*, in *F* is again opened, admitting water to the coils of the generator under pump pressure.

In connection with this system of controlling the boiler feed, there is a thermostat regulator, shown at *P Q*, for varying the amount of gasoline fuel fed to the burner, or cutting it off entirely. This, however, will be explained in the chapter on burners and fuel feed regulators.

The "Victor" Steam Air and Water Pumps.—The automatic auxiliary feed pumps used on the "Victor" carriage and shown in section in the accompanying illustration are operated on a principle which has already been applied to the steam air pumps used in connection with the Westinghouse air brake on

many American railroad locomotives. As will be seen in the illustration, two such automatic pumps are used on this carriage, the one being intended as an auxiliary feed pump for the boiler, to be used in case the regular feed pump, which is of the double-plunger type, being geared to and operated from the rear axle, should from any cause cease to operate. The other pump is used for maintaining the acquired air pressure in the fuel tank. The steam is admitted through the port marked "steam inlet" in the accompanying diagram; this port leads into an elongated

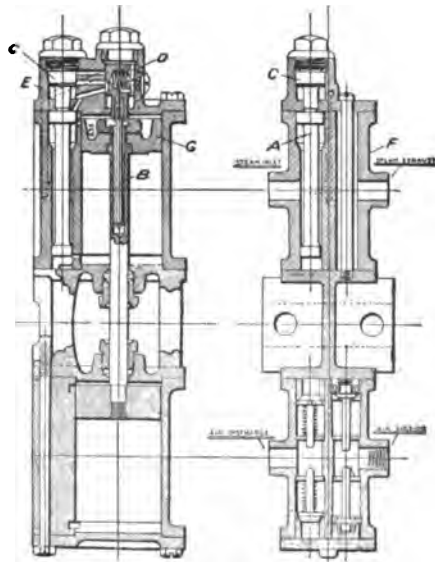

FIG. 200.—Sectional View of the Valve Motion and Mechanism of the "Victor" Auxiliary Steam Pumps.

chamber running the full length of the cylinder, and of somewhat enlarged diameter towards the top. Within it, as may be seen, is a vertical rod, carrying a piston valve at either extremity. The steam on entering, of course, bears against these pistons, and since the upper one of the two is of the largest diameter, it forces it into the position shown in the cut, thus opening the port into the upper end of the cylinder, and forcing the piston downward. The downward stroke continues until a shoulder at the lower end of the rod, *B*, strikes the nut fixed

above *G*, opening the valve, *D*. Communication is thus established between the valve chest, in which slides the double piston rod, *A*, and the space above the piston, *C*. Consequently, steam is admitted above this piston, which, being of larger diameter than the piston below it, forces it and the valve rod downward, thus opening the steam port into the bottom of the cylinder, and so beginning the up-stroke of the piston. The up-stroke continues until the nut above piston, *G*, closes valve, *D*, thus cutting off steam from the space above the piston, *C*, and again causing the plunger to rise. The position of the exhaust valves is such that they are covered by the piston valves on rod, when these are in position to open the inlets, and are opened again as soon as the inlets are closed, thus establishing communication with the exhaust chamber, *F*. The operation of the valves of the pump is obvious and requires no further description.

The Moore Steam Pump and Valve Motion.—The Moore feed pump, which has been widely advertised for use on steam carriages, differs considerably from the one just described, although equally ingenious in construction. The steam cylinder, which is shown in section in an accompanying cut, contains a double-headed piston, *B*, shaped somewhat like a spool. Both heads of this piston, *B*¹ and *B*², slide team tight within the cylinder, being formed with suitable packing rings. As shown in the cut, one of these cylinder heads, *B*², is screwed upon the body of the piston, thus permitting its removal in order to slide on the cylindrical valve, *G*, which is similarly shaped, having two heads, *G*¹ and *G*², also formed with packing rings, fitting against the inner surface of the cylinder. Within the body of the piston, and connecting with either end of the cylinder, are two longitudinal channels, *g* and *h*, each of which communicates by a port through the circumference of the piston body. As shown in the separate cut of the piston, there is also a port, *k*¹, which penetrates clear through the body of the piston and is in communication with the hollow piston rod, *E*. In the cylindrical valve, *G*, there are, as shown, two sets of ports, *c* and *d*, which communicate respectively with the annular grooves, *e* and *f*. Around the inner circumference of this cylindrical valve, there is also another annular groove, *i*, several times wider than the other two.

The operation of this mechanism is simple and effective. The cut shows the piston in progress from left to right, the steam being admitted into the cylinder through the inlet pipe, *F*, and the two ports, *a* and *b*, flowing thence through the port *D*, the annular groove, *f*, the longitudinal channel, *h*, to the rear of the piston, thus causing it to move toward the right. In the position shown in the cut, the head, *G*², screwed on the extremity of the cylinder valve, *G*, has closed the steam port, *A*. As soon, however, as the piston has reached the end of its stroke, and the head, *B*¹, has pressed against the relief groove, *o*, the steam

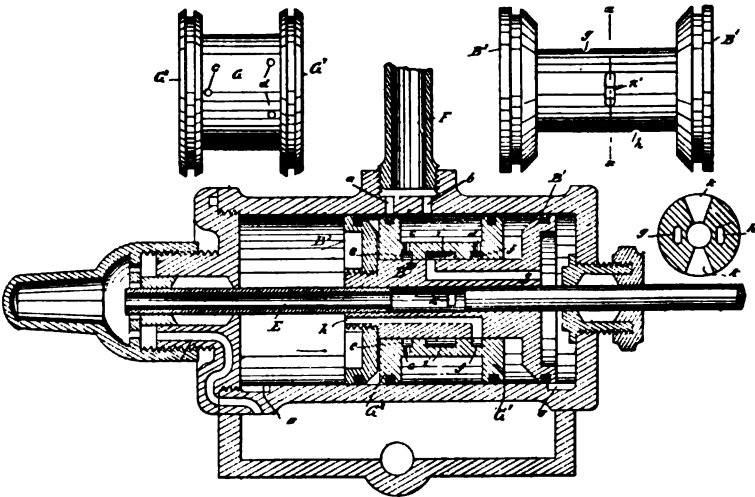

FIG. 201.—Section showing the Valve Motion and Mechanism of the Moore Steam Pump used on some Steam Carriages.

being unable to force the piston further, acts upon the sliding cylinder valve, causing the head, *G*², to move away from the head, *B*¹, thus opening the communication for the return stroke by bringing the port, *c*, and the annular groove, *e*, opposite to the longitudinal channel, *g*, causing steam to flow to the right-hand end of the cylinder. At the same time, the annular groove, *i*, is brought opposite to the opening of the longitudinal groove, *h*, thus establishing communication between the left-hand end of the cylinder and the exhaust port, *k*, communicating through the hollow piston rod to the rear of the cylinder, where

the exhaust is taken off. The cylinder thus constructed is capable of high speed and considerable efficiency, although, like the one just described, it operates almost altogether at boiler pressure, allowing the steam little if any opportunity to expand. This feature, which is largely common to all automatic cylinder valves, forms one of the greatest objections to their use in connection with small boiler plants, the waste of steam soon amounting to a considerable item if they are to be operated constantly.

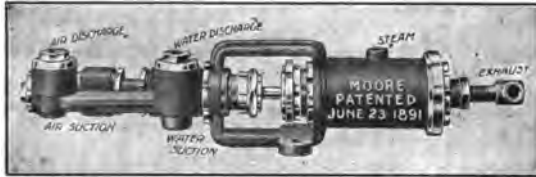

FIG. 202.—The Moore Steam Pump arranged to operate both Air and Water Supply for Steam Carriages.

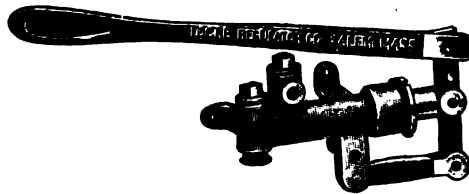

FIG. 202a.—Typical Hand Pump for Steam Carriage Use. This style of pump is used on a large number of American steam carriages, and is an indispensable adjunct—its object being to supply water to the boiler when, for any reason, the automatic pump fails to work. The particularly advantageous feature is the jointed hand lever, which may be bent back out of the way, when not in use, and readily brought to the driver's hand, when necessary.

CHAPTER SIXTEEN.

LIQUID FUEL BURNERS AND REGULATORS.

Of Liquid Fuels in General.—All light steam carriages, and many heavier vehicles as well, use liquid fuel, oil or mineral spirit, to produce heat for their boilers. Such liquid fuel is not burned in liquid form, as is oil in an ordinary lamp, but is vaporized by heat, the vapor or gas thus produced being fed to the burner and ignited, in the same manner as ordinary coal gas used for light or heat in houses. It would be impracticable to carry gas in tanks on steam carriages, since the difficulty of storing and replenishing the supply would be greatly increased. Now, as the idea of vaporizing liquid hydrocarbons, instead of depending on coal gas supply for a gas engine, was one of the most valuable improvements made by Daimler, and the first step toward the gasoline motor carriage, an analogous treatment of volatile liquids, in order to produce gas for burning under a boiler, was the first departure in the direction of a really practical and easily handled light steam road carriage. By the use of liquid fuels in such a carriage, a vast saving is made possible, both in space and weight, while the consumption of such fuels in gaseous form is another element of economy.

Advantages in Using Volatile Fuels.—A prominent English authority on motor carriages gives the following five considerations of advantage in the use of liquid fuels:

1. Their combustion is complete, no heat being lost in the form of smoke or soot.
2. They produce no ashes or clinkers, which must be periodically cleaned out. Hence there is no loss of heat or drop in steam pressure, due either to this cause or to the renewal of coal.
3. The flues are never incrustated with soot, which involves the best conditions for use of heat.
4. The temperature of the escaping gases is lower than with a coal fire, since there is no need that the air required for combustion should force its way through a thick layer of burning

fuel. Whence the uptake temperature is generally about 400°, Fahrenheit, instead of between 600° and 700°, as with the use of coal fire.

5. Since the fuel is burned in fine particles, in close contact with the oxygen of the air, only a small excess of air over that actually required for combustion is admitted to the burner. The opposite is the case with coal.

As may be readily surmised, the calorific value of liquid fuels is far greater than that of coal. It has been estimated that, taking the two weight for weight, petroleum oil has about twice the heat efficiency of coal. Since, therefore, equal weights of both varieties of fuel occupy about equal spaces, it follows naturally that petroleum products are far more economical and serviceable for use in vehicles of any description, or in boats and ships, where the considerations of weight and space occupied, in ratio to the power, are all-important.

The liquid fuels most commonly used are kerosene and gasoline, both being vaporized by the heat of the burner; a kindling flame from liquid gasoline or alcohol vapor, or a specially arranged detachable auxiliary vaporizer, or "torch," being used at the start, and until the vaporizing tubes are thoroughly heated. Kerosene is less suitable for steam carriage burners than is gasoline. A far higher temperature is required to vaporize it, and a larger evaporating surface. Furthermore, it requires large, bulky and complicated burners to consume its vapor, and very frequently produces an excessive amount of carbonaceous residuum, which necessitates periodical cleaning and considerable trouble in generating heat. Kerosene burners are also more difficult to operate and regulate; frequently make an annoying "roaring" sound, and, on the whole, are highly unsuitable for light steam carriages which require the simplest and most readily handled, as well as the least annoying, attachments. Gasoline, on the other hand, being a highly distilled product of petroleum, is more readily vaporized and its combustion produces no dirty residue. Moreover, its gas may be readily burned in the compact and simple burners used on most steam carriages.

Kerosene Burners: The Longuemare Burner.—Most of the best known kerosene burners use coils of tubing for vaporizing the oil under heat in valve burners, whose rate of consumption

and consequent heat may be readily adjusted. The Longuemare burner, one form of which is shown in an accompanying figure, has been much used in connection with the Serpollet flash generators. The liquid oil is fed into a tubular spiral, *B*, which is of a general conical contour, as shown. Entering at *A*, it passes through all the tiers of tubing, becoming vaporized under the heat. Being given off at the top, it passes down to the central chamber of the burner at *D*, rising thence to the burner tips, *G, G, G*, in such quantities as are permitted by the needle valve at the end of the rod, *E*. Two other burner tips on arms fixed at right angles to *G, G, G*, are connected to the central chamber

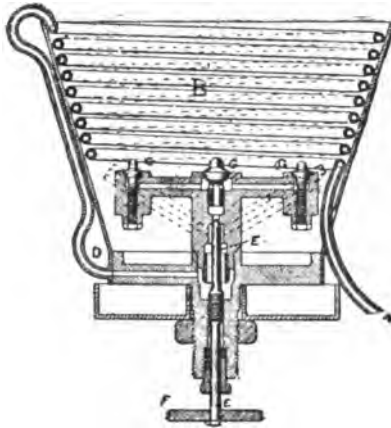

FIG. 203.—The Longuemare Kerosene Vapor Burner. *A* is the oil feed pipe; *B*, the vaporizing coil; *D*, the tube leading to the burner tips; *E*, the control valve; *F*, the hand-wheel for regulating the control valve; *G, G, G*, the burner tips and glands.

below the needle valve, as is indicated by the dotted lines. Consequently, when the rod, *E*, is screwed up, by the geared wheel, *F*, so that the needle valve is closed, these two burners are still supplied from the central chamber; thus maintaining about half the usual amount of heat, when it is necessary to stop the engine for a moderate period. These burner tips also act as pilot lights to ignite the others when the valve is again opened. In starting the burner, it is necessary only to pour alcohol into the pan shown beneath the tube, *D*, and the central chamber of the burner, and this having been ignited furnishes sufficient heat to begin the

process of vaporizing the oil, the pilot burners being kindled from its flame.

The Clarkson-Capel Kerosene Burner.—The Clarkson-Capel burner resembles the Longuemare in that the oil is fed into the base of a coil of pipes and the gas is given off at the top. But its general details are very different. The oil is forced into the vaporizing coil, *B*, through the tube, *A*, and the oil gas passes off through the tube, *C*, which extends through the boiler shell, as shown, to the valve, *D*. The needle valve, controlled by the lever, *E*,

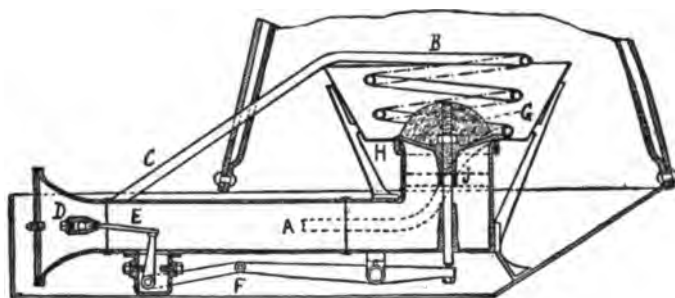

FIG. 204.—The Clarkson-Capel Kerosene Vapor Burner. *A* is the oil feed tube; *B*, the vaporizing coil; *C*, the pipe for gas for regulating valve; *D*; *E*, the spindle of the needle valve; *F*, the operating lever of the valve; *G*, the gland of the burner; *H*, the variable opening for the flame.

E, admits the gas to the large mixing tube, into which air also enters by a rotary valve, of the general type used on small stoves, placed at the end of the tube to the left of the diagram. The act of operating the lever, *E*, on its pivot also actuates the double-jointed lever, *F*, which, as may be readily understood, moves the stem, *J*, of the burner gland, *G*, up or down, thus controlling the quantity of gas let out at the point, *H*, hence, also, the size of the flame. By this device the heat under the boiler may be varied and regulated by a single turn of the hand far more effectively than in the Longuemare burner, as just described. This burner is started by the use of a hand torch, which heats the vaporizing coil previous to admitting the oil. When the tube is sufficiently hot the burner is ready to begin work, and may be lighted as soon as the gas and air mixture in the large mixing tube is allowed to escape through the vent at *H*. Although very

complete and readily operated, such a burner is not suitable for small carriage use.

The "House" Kerosene Burner.—Another oil vapor burner for heavy vehicles is the House burner, which is intended primarily for use with the "Lifu" tubular boiler, already described. As shown in the accompanying figure, it consists of two parts—an upper chamber containing a series of channels, into one end of which the oil is fed, being vaporized under the heat of

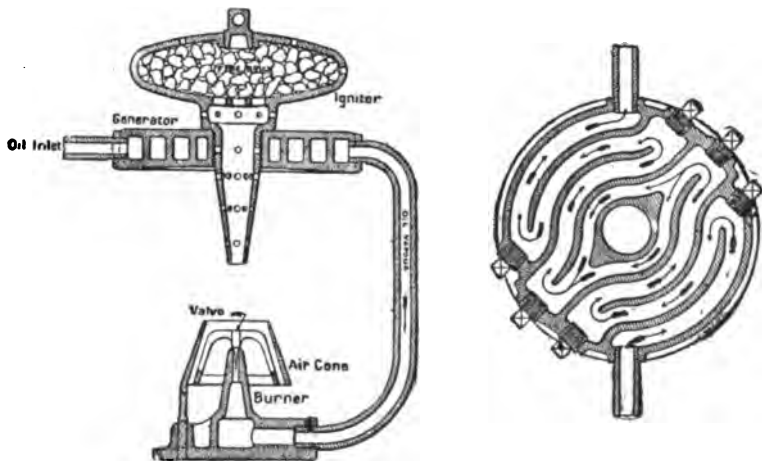

FIG. 206.—The "House" Kerosene Vapor Burner, section in elevation, and plan section of the vaporizing chamber, or "generator," showing course of oil in process of being converted into vapor under heat of the flame.

the burner and given off through the opposite port, and the burner into which the vapor is led by a vertical tube. The oil vapor, passing down into the burner, lifts the needle valve by its own expansive energy, thus varying the size of the opening and of the flame, in ratio to the force and quantity of the oil vapor. This matter is controlled by an automatic diaphragm regulator, similar to that used with gasoline burners, by which the steam pressure of the boiler can act to vary the opening of the oil inlet valve; a low pressure leaving it fully open and a high pressure acting to close it to any required degree. According to reports this method of regulation acts very effectively in this burner, although not as simple as the thermostat device

used on the Blaxton flash generator, where the valve and burner tip are of the same general construction, being held open by the force of the oil vapor until mechanically closed by the lengthening of the tube.

Another excellent feature of the House burner is the igniting chamber, situated, as shown, above the generating chamber. This is a spheroidal cast-iron box having perforations at the base into the tube fixed immediately above the burner tip. It is filled with fire brick, or some similar non-conducting substance, which

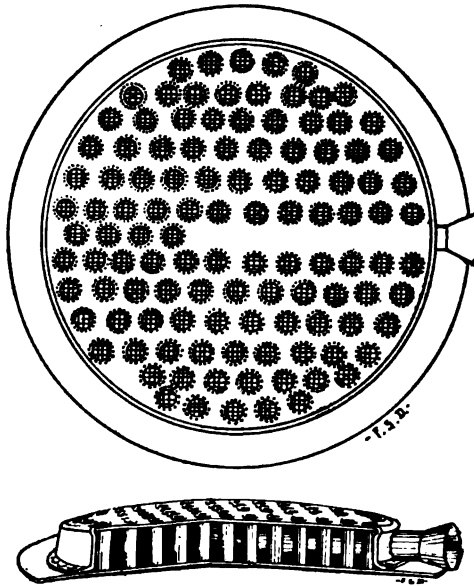

FIG. 206.—Plan and Part Section of a typical Gasoline Burner for Steam Carriage Use.

is heated to redness by the flame of the burner and is thus useful in rekindling the flame, if at any time it is blown out by draughts under travel or by rush of air from the oil tank. The flame produced is a very large and hot one, amply sufficient for the utmost requirements of the boiler. When the oil supply valve is opened full, the pressure is sufficient to lift the valve of the burner and atomize enough oil to enable starting the flame, which continues with gas, as soon as the generating chamber is heated.

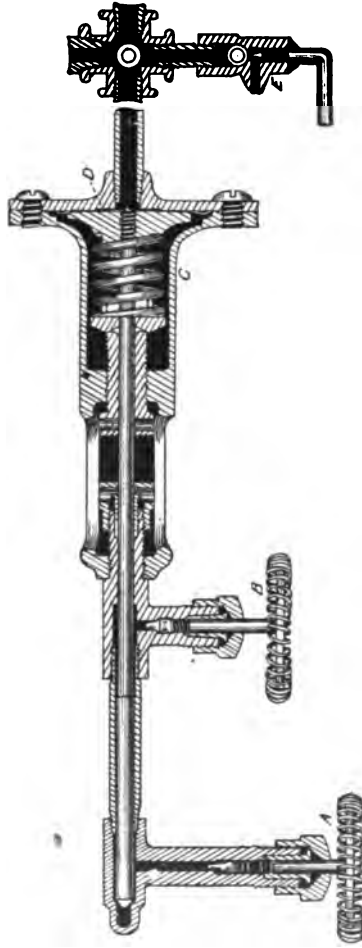

FIG. 97.—Fuel Feed Regulator of a Steam Carriage Burner, intended for use with "Torch" Burner Kindler or Auxiliary Vaporizer. A is the hand wheel and needle valve regulating the feed to the main burner; B, the hand wheel and valve for operating the torch; C, the spring and header attached to the main valve rod; D, the diaphragm against which steam bears, regulating the main valve according to pressure; E, the drip valve for condensed steam on the steam inlet to diaphragm. The liquid gasoline is admitted at a port on the left-hand extremity of the regulator tube, near the end of the needle valve on the main rod.

Gasoline: Its Vaporization and Burning.—Gasoline is much more readily vaporized than kerosene, requiring generally no greater temperature than may be obtained by passing the supply pipe up through one flue of the boiler and down through another. Such heating as this would have very small effect on kerosene. The burners used for gasoline are simpler and more readily regulated than those used for kerosene. They may also be made much lighter in comparison to their heating power and are less difficult to fire up at the start. All these points are distinctly advantageous, if not imperative, on a light steam carriage, intended for amateur engine drivers. On a heavy wagon, intended to be managed by skilled engineers, they are of less importance, and may be readily superseded by the more complicated devices for using the cheaper fuel.

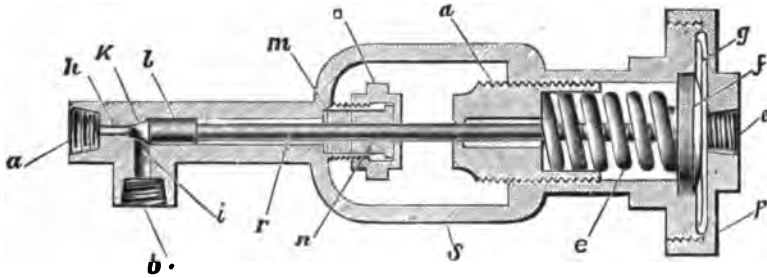

FIG. 206.—The "Locke" Diaphragm Fuel Feed Regulator. Unlike the one shown in Fig. 207, this device is constructed to operate with some firing device other than a "torch." The parts shown are: *a*, gasoline supply pipe, whose opening is regulated by point, *k*, on valve head, *l*; *b*, gasoline delivery to burner; *c*, steam inlet; *g*, diaphragm; *f*, pressure head; *r*, valve rod; *o*, packing nut; *n*, gland; *m*, asbestos spring packing; *a*, main frame; *d*, adjusting screw for regulating tension of spring; *e*; *p*, cover of pressure chamber, screwed to head of *m*, as indicated.

The Gasoline Burner.—Very nearly the typical gasoline burner for steam carriages is shown in an accompanying figure. It consists of a flattened cylindrical chamber, pierced from head to head by a number of short tubes, each of which is expanded into the holes prepared for it and flanged over to make a secure joint, somewhat after the manner of a well-made boiler flue attachment. These air tubes, as they are called, are open to the air at top and bottom, having no communication with the interior of the cylindrical chamber above referred to. The gasoline enters the chamber, from a nozzle at the end of the feed pipe and through a tube entering at one side of the cylinder and extending inward

about two-thirds the diameter. This tube is called the "mixing tube," and its function is to make a mixture of air and gasoline vapor that will burn readily in the atmosphere. Having entered the cylindrical chamber, there is no avenue of escape for the inflammable gas except through the circular series of pin-holes, which surround each one of the air tubes, as may be seen on the cut of the top of this burner. It is at these minute perforations that the gasoline gas is ignited, the combustion being rendered perfect by the air admitted through the air holes previously mentioned. As may thus be understood, the devices necessary to perfectly burn gasoline are as simple as the ordinary "hot plate," or gas range burner, that are familiar adjuncts to many well-equipped kitchens. Of course, since a more extensive burning surface is required in a steam carriage



FIG. 209.—The "Dayton" Fuel Feed Regulator. This device differs from the others shown in that it has not two chambers necessitating that the valve rod pass through a packing gland. The cover, B, is attached to the end of the diaphragm chamber by small screws, but both may be detached, by threaded connection, from the spring and head chamber, thus avoiding removal of the diaphragm. The valve rod carries a needle valve controlling the gasoline inlet at M, and its outlet at L. The compression spring is adjusted by the stud, H, passing through the packing gland, G.

burner, the plan and construction must differ considerably from the more familiar models of gas heater.

The Storing and Feeding of Gasoline.—The liquid gasoline for supplying gas to the burner of a steam carriage is carried in a tank, disposed generally to the front of the body, and sufficiently separated from the burner to avoid all dangers that might arise from leaks or overheating. Within this storage tank a good pressure of air is maintained—generally between 35 and 45 pounds to the square inch—from a separate air tank, supplied by a pump. This pressure is sufficient to force the liquid gasoline into the vaporizing tubes, when the supply cock is opened. After it has been vaporized the circulation continues, as controlled by

the steam pressure diaphragm regulator, which operates a needle valve on the tube supplying the burner, the amount of gas and liquid gasoline moving between the supply tank and the burner being thus determined.

The pressure in the air tank is produced and maintained, either by a small hand pump, such as is used to inflate pneumatic tires—this method is used on several well-known American steam carriages—or else by some such specially designed pump, as is used on the Victor carriage, or some of the others described. Such steam driven air pumps are further useful, in that, by proper attachments, they may also be used for inflating the tires.

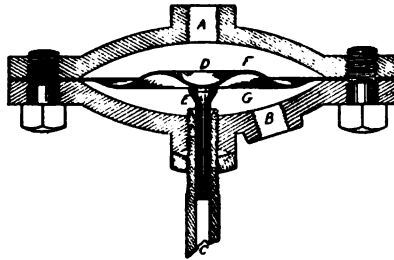

FIG. 910.—Gasoline Burner Regulator, operating with a corrugated diaphragm, like a steam gauge. A is the inlet for steam; B, the inlet for liquid gasoline; C, the port leading to the burner; D, the diaphragm; E, the head on the grooved rod of the valve; F, the steam chamber; G, the gasoline chamber.

The Automatic Fuel-Feed Regulator.—The fuel-feed regulator, of which there are several serviceable forms, is one of the most necessary attachments of a steam carriage. Generally, it consists of a diaphragm, which, actuated by steam pressure from the boiler, automatically closes, or partly closes, a needle valve, thus regulating the amount of fuel fed to the burner. Several such apparatus are shown in section in accompanying cuts. There, as may be seen, the diaphragm is fixed across the tube leading from the steam space of the boiler. Against its inner side bears a solid head, or pressure cap, carrying a rod, at the farther end of which is a needle valve. The pressure cap is normally held against the diaphragm by a strong spring. When sufficient steam pressure bears upon the diaphragm, the spring is compressed, allowing the rod attached to the head to be pushed inward, thus regulating the needle valve, according to requirement. The instrument, thus formed, consists of two parts. The

one is the pressure chamber containing the spring, whose pressure on the head is regulated by an adjusting screw, through the shaft of which passes the valve rod. The other is the gasoline chamber, into which the fuel for the burner is admitted to the left of the point of the needle valve; its outlet being controlled, as shown, by two hand-wheel valves—one leading to the main burner through the mixing tube, the other being intended to let out a sufficient supply of gasoline to the starting device, which may be a detachable "torch," or auxiliary vaporizer, or some arrangement of drip cup and preliminary generating coil. This arrangement of the valves is shown in different cuts of burners and automatic regulators, being there sufficiently designated. Thus, as shown in the figures, the valve rod, in entering the gaso-

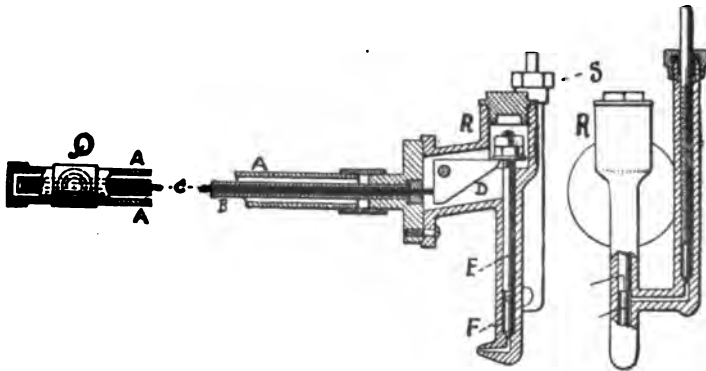

FIG. 211.—The White Thermostat Fuel Feed Regulator. A is a tube extending clear through the body of the steam generator and forming the connections of two of the coils, as at Q. B is a tube contained within A, and around which steam circulates; C, a rod contained within B; D, a bell crank regulating the valve, E, as C lengthens with heat; F, the point of the valve; R is the valve chamber, and S the gasoline inlet chamber regulated by a needle valve on a screw-threaded rod.

line end of the regulator, passes through a stuffing box, so as to prevent all leakage at that end.

Of course, until there is sufficient heat generated to vaporize gasoline for the regular burner and generate steam pressure in the boiler, the automatic regulator cannot operate, as described, and the flow of gasoline to the starting burner or vaporizer is regulated solely by the hand valves.

A Heavy Vehicle Gasoline Regulator—An automatic regulator, constructed on the plan just described, will work eminently well so long as the spring is not too much compressed by the

adjusting screw and the gland of the stuffing box is not drawn up too tight. Another form of regulator, also shown in an accompanying cut, which is used on steam wagons, has the advantage of simplicity in this particular, doing away with both spring and stuffing box. The diaphragm has concentric corrugations, like those used on diaphragm steam gauges, and to its centre is attached a valve rod having longitudinal groovings to permit the fuel to enter the feed tube in such quantities as the pressure on the other face of the diaphragm will permit. Steam pressure, being thus brought to bear, tends to deform the diaphragm; hence compressing the valve rod and decreasing the rate and

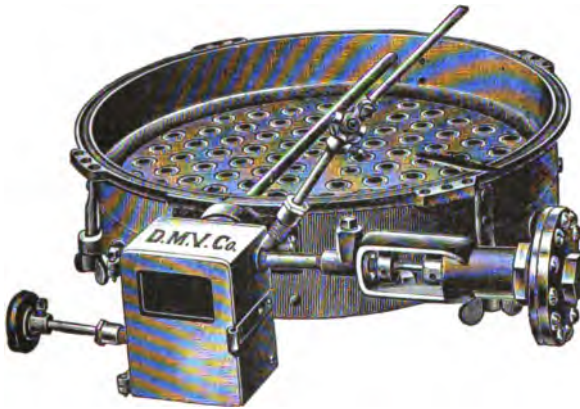

FIG. 212.—The Dayton Burner, showing the Starter Box and Regulator in Position.

quantity of fuel feed. The fuel is supplied from the storage tank through the port into the lower chamber of the two formed by the diaphragm, as may be readily understood.

A Thermostatic Fuel Feed Regulator.—The automatic regulator used on the White steam carriage is a true thermostat device, like that used on the Blaxton generator, although regulating the fuel supply rather than the burner flame. Its position and connections are shown on the figures of the White water feed system, where it is designated as *Q*, *R*, *S*. As shown in an accompanying figure, it is constructed, as follows: A tube, *A*, *A*, *A*, extends entirely through the diameter of the generator, forming, in fact, the connection between the two lowest coils of

the White steam generator, and being connected at one end on the point, *Q*, and at the other on the sleeve there shown. Within this tube, *A*, is another one, *B*, secured, as shown, to the head piece at the right hand end of the tube in the figure. This second tube is preferably of copper, and around it, within the tube, *A*, the steam circulates freely between the two lowest coils, so long as the generator is in operation; thus determining its temperature and consequent expansion. Within this second tube, *B*, again, is the rod, *C*, preferably of iron or steel, whose ratio of expansion is smaller than that of copper for all usual boiler temperatures. This tube, *C*, bears upon the bell crank, *D*, normally holding it in the position shown. When, however, the temperature of the steam or air within the tube, *A*, has reached a certain predetermined maximum, the tube, *B*, of copper, expands accordingly, lengthening in the direction of the left of the figure, on

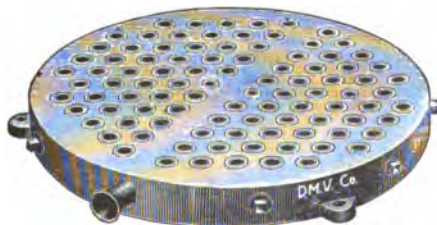

FIG. 213.—One-piece Cast Burner Body of the Dayton Burner.

account of being rigidly secured to the head at the right. The result is that the linear expansion of *B* and *C* being unequal, *C* is drawn away from the bell crank, *D*, with the result that the rod, *E*, is allowed to fall accordingly, decreasing or quite closing the needle valve at *F*. This regulates the flow of gasoline gas from the casing, *S*, which, as shown in section, contains the main needle valve, to be controlled by a hand wheel operated from the seat of the carriage. The general location of this device, also that of the hand wheel to control it, are shown in the sectional cut of the water feed system above referred to.

Constructional Points on Gasoline Burners.—Several steam carriage burners are formed by riveting together a steel flattened cylindrical pressing and a plane disc, as shown in a former figure, inserting and expanding the draught tubes into suitably arranged

perforations, as is done with the flues of boilers. Such a construction is apt to be faulty, however, owing to the fact that the steel plates tend to warp under the influence of heat, causing the draught tubes to leak, and the attachments to wear. The danger of these accidents has moved several inventors and manufacturers to design and produce burners formed with a cast top and steel plate base, or to cast both elements. By the use of castings warping is positively prevented, and leaking at the joints of the draught tubes is obviated.

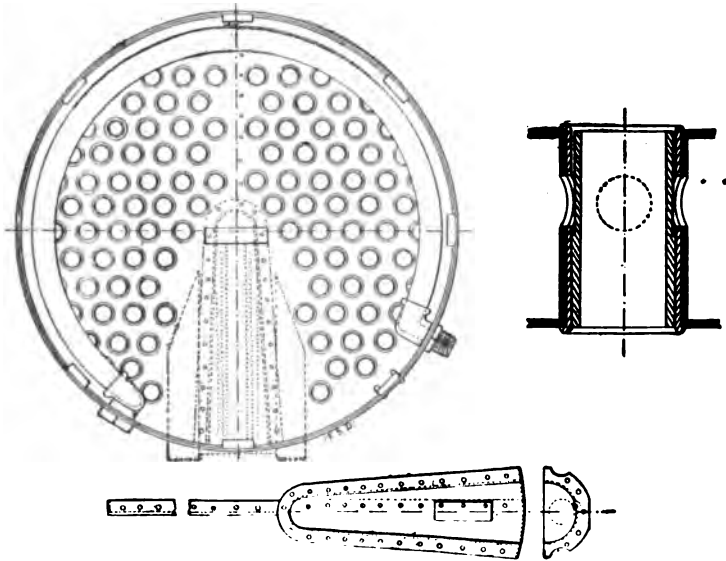

FIG. 214.—Whitney Bunsen Tube Burner of the McKay Carriage, showing section of one of the Bunsen tubes, and starting torch.

One of the best-known burners of this construction is that widely known as the "Dayton," which possesses the additional feature of supplying gas for the burner flame through annular openings around each of the draught tubes, instead of using the "pin-hole" design, already described. It is possible to construct with this feature, since the air tubes are cast in one piece with the head and base plates, being afterward reamed out, so as to make them uniform in size. In addition to this air opening, a counter-bore is sunk in the top plate of the burner, and a steel

washer is fitted into it, leaving an annular opening for the passage of gas in the inside of the washer. The outside of the washer has a number of small openings in it, so that each air tube is surrounded by two concentric circles of flame. This construction affords a very large heating capacity, and also, as is claimed, prevents the top of the burner from cracking, also less liability of choking with rust, dust or carbonized particles, which is a frequent source of annoyance with "pin-hole" burners.

A Bunsen Tube Gasoline Burner.—An interesting variation on the common type of steam carriage burner is presented in the device used on the McKay carriage. This burner is made with the usual top and base plates, the air tubes being inserted and flanged over, as already described. There are, however, no slits or punctures around these for the gas to pass through. Instead of this usual construction, each tube is perforated on each 90° of its circumference, as shown; thus making communication to the interior of the gas chamber within the flattened cylinder. A second tube is then inserted within the first, fitting closely, except for a slightly diminished circumference at about the level of the perforations just mentioned. This construction is shown in the figure illustrating the section of one of the draught tubes. The gas from the mixing chamber, entering these perforations, passes between the two tubes, where the inner one is of diminished circumference, and, mixing at the top of the tube with the air drawn through the draught tube, produces a very hot flame, as in the ordinary type of Bunsen gas burner.

In addition to the possible advantage in point of heat obtained by this construction, it seems quite reasonable that "burning-back," or the ignition of the gas within the mixing chamber, caused generally by a sudden gust of wind from above, would be largely obviated if not wholly prevented. It has been asserted that the "pin-hole" burner is superior to other designs, in point of immunity from "burning-back."

"Burning-back" in a carriage burner may always be detected by a roaring sound, accompanied by a fall in the steam pressure. It may be remedied by cutting off the fuel supply, and allowing the burner to cool somewhat before relighting. If allowed to continue it will result in considerable damage to some burners, and in no profit to any. It also cuts off the heat from the boiler.

A Tubulous Gasoline Burner.—An interesting burner, whose construction quite precludes the possibility of burning-back, is used on the Lane carriage, a sketch being shown herewith. Instead of the familiar mixing chamber and draught tubes, it consists of a central mixing tube of about three inches diameter from which start out at both sides, on one plane, 34 tubes of about $\frac{3}{8}$ inch diameter having pin-hole perforations through their entire length. The fire being kindled on all of these holes, a much more extensive burning surface is rendered possible than can be obtained on any of the common type of burner. A further advantage claimed is that the draught, arising through the spaces

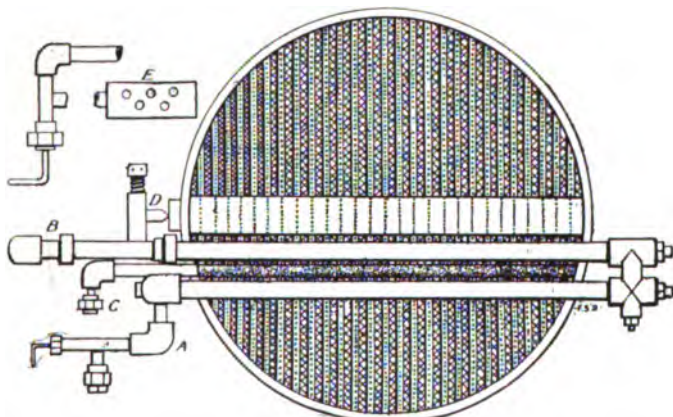

FIG. 215.—The Tubulous Gasoline Burner of the Lane Carriage. A is the tube leading from the gasoline tank and across the burner space; B, the tube leading from the vaporizer tubes to the pilot burner, main feed and regulator; C, the tube for pouring alcohol into the torch; D, the connection of the main burner feed and nozzle; E, elevation of B, showing pilot burner.

between the tubes, gives the fire air for combustion on both sides through the entire length of every tube; thus enabling a hotter flame than is possible in any other manner. The central mixing tube also has perforations from side to side, as shown, thus making the lines of flame continuous across the entire burner structure. Another advantage of a straight-tube construction is that expansion or contraction may occur without involving warpage or undue strain at any point.

The gasoline fuel is fed to this burner through the tube and connections marked A. This tube, as may be seen, has an adjust-

able needle valve for setting the rate of supply at any desired point, when the automatic regulator is allowing passage for the full supply, or for shutting it off entirely. From the point, *A*, the fuel passes entirely across the face of the burner through one of the vaporizing tubes and, back again through the other, which

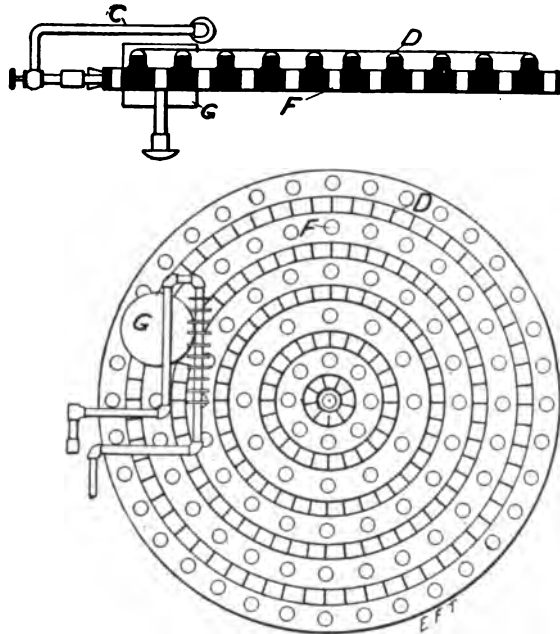

FIG. 216.—Plan and Sectional Elevation of the White Burner.

is marked *B*. One part of the vaporized fuel, reaching this point, passes through the tube and spraying nozzle at *D* into the mixing tube, which runs through nearly the entire length of the large cross-perforated central tube, and is fed thence to all the burner tubes set at right angles thereto. Another part is fed into the pilot burner, *E*, which is arranged directly beneath the tube, *B*, as shown in the detail to the upper left-hand side of the burner. This pilot light, which may be kept continuously burning, can rekindle the fire at any time after extinguishment.

Another feature, which, however, is not peculiar to this burner, is the method of starting the fire. This is done by pouring a few

teaspoonfuls of wood alcohol into a tube connected on to the tube, *C*, which also passes across the face of the burner between the two vaporizing tubes, *A* and *B*. This torch tube, *C*, is also perforated with pin-holes through its length, and is wrapped about with asbestos packing, which may be ignited; thus furnishing sufficient heat to begin the operation of vaporizing the fuel in *A* and *B*. Before the prescribed quantity of alcohol is burned out, clear gas begins to be fed to the pilot burner and mixing tubes; being ignited in both by the flame of the asbestos torch.

The White Gasoline Burner.—The burner used on the White carriage is also an interesting departure from the common types. As shown in the plan and sectional sketches, it consists of an upper, or face, plate of cast iron, having concentric corrugations, between which are the draught tubes, connecting the top and base plates, as in other burners. Instead, however, of the usual pin-holes or slits around the openings of the draught tubes, there are concentric rows of radially disposed slits across the raised corrugations on the face of the upper plate. The sketch shows these in larger number than on the burner in actual use, which, being about 14 inches in diameter, has the slits arranged at intervals of about $\frac{1}{8}$ inch.

Obvious constructional and practical advantages inhere in this design, since: (a) The draught tubes, being separated from the flame, cannot be loosened by the heat. (b) Being arranged to either side of each circle of flame, sufficient oxygen is supplied to produce perfect combustion. (c) The construction is such that there is no danger of warping or deformation under heat.

The automatic thermostatic regulator, described above, is used with this burner. The incoming gasoline supply goes to the preliminary vaporizer, *C*, over the pilot burner, *G*, thence through the vaporizing tubes, and through the regulator, and into the mixing chamber, whence it emerges through the fire slits, *D, D*.

Methods of Starting the Fire: The "Torch."—There are several methods of starting the fire in gasoline carriage burners, each having been devised as an improvement in way of simplicity and ease of operation.

The most familiar method of starting the fire is by the use of a

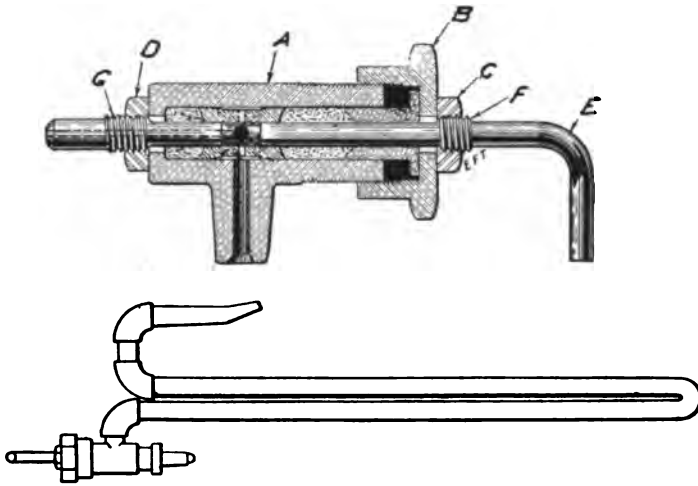

FIG. 217.—Usual pattern of "torch" head and starting "torch," used on several American steam carriages. The head parts are lettered as follows: A, body of head; B, threaded cap; C and D, nuts working on screws, F and G, on rod, E. Screw, G, gives attachment to the collar on the valve stem, as shown at B, in the succeeding figure.

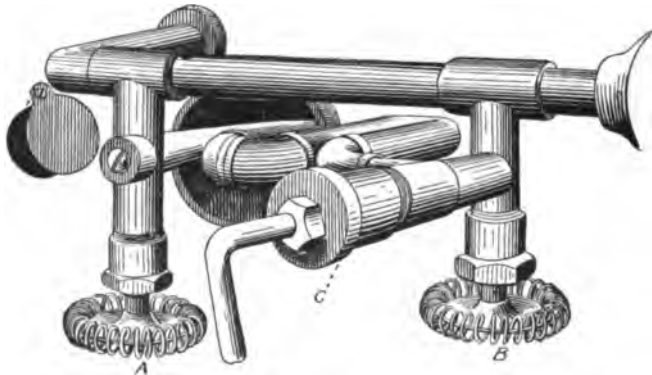

FIG. 218.—Showing the torch in position. By reference to Fig. 217, it may be readily understood that the head of the torch, C, is attached to a nipple on B by screw, G; the bent tube being thrust through a port in the burner casing so as to come directly over the fire; the nozzle entering the mixing tube by the side of the nozzle on the main valve, A.

removable auxiliary vaporizer, or "torch," such as is used on the "Mobile," and several other well-known steam carriages. It consists, briefly, of a continuous iron tube bent double at the centre, as shown, and having a cock and screw head at one extreme and a tapering nozzle at the other. This instrument is held in the fire of an ordinary stove, or over a fire kindled with cotton waste saturated with gasoline, until it reaches a temperature usually described as a "sizzling heat," which is to say the point at which any moisture applied to its surface will occasion

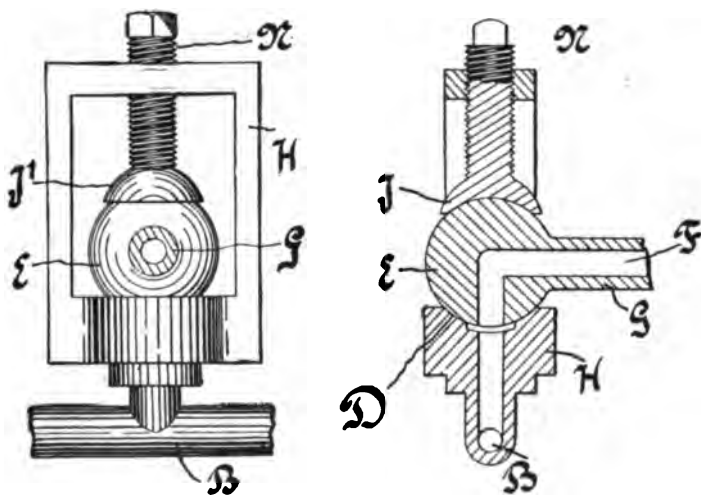

FIG. 319.—The Perrott Improved "Torch" Head. The frame, H, is permanently attached to the nipple of the regulator gasoline outlet at B. At its top, H carries the screw, N, with the cup-shaped clamp end, J. The spherical head, E, having the internal channel, F, is attached at the end of one leg of the "torch" by the neck, G. When the "torch" is heated and inserted in the burner space, the head, E, is placed in position, as shown, and secured by the screw clamp, so that the channel, F, connects direct with B, thus permitting gasoline to flow into the "torch" tubes. The particular advantages claimed are the absence of movable screw joints, which are apt to suffer from heat, and also the avoidance of all packing.

the familiar "sizzle," noted when water is dropped on a stove lid. It is a heat just below the point where iron begins to redden. Some authorities advise that the "torch" be heated to a "dull red," as that will give a better temperature, when it is inserted in the burner.

The "torch," having been heated, its double bent tube is inserted in an aperture in the burner casing, designed to receive it, the screw and valve end being attached at an aperture controlled

by the pinvalve and hand-wheel, *B*, in the sectional cut of the automatic regulator, and its nozzle being inserted in the same aperture as is penetrated by the nozzle controlled by the pin valve and hand-wheel, *A*, in the same figure. This done, the hand-wheel, *B*, is turned, so as to open the needle valve at the end of its stem, as far as is required; thus admitting liquid gasoline into the double bent tube of the torch through the screw and valve attachment. The result is that, passing through the heated tube, it is vaporized; sufficient gas being presently generated to allow the burner to be ignited by a match or paper lamplighter thrust through an aperture prepared for that purpose. The merits of this arrangement are obvious, although it has been repeatedly

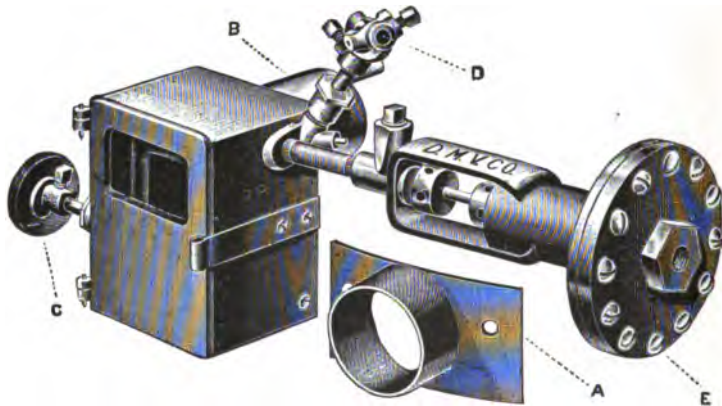

FIG. 220.—Starter Box and Diaphragm Regulator of the "Dayton" Burner. The parts are: A, segmental plate and collar at opening of the mixing tube; B, thimble on starter box containing supply pipe to the mixing tube and burner; C, starting valve; D, knuckle joint for connecting control valve to driver's seat; E, head piece of the diaphragm regulator.

objected to on the ground that it is a rather clumsy and inconvenient arrangement, requiring, as it does, some stove or fire to produce the required heat. Thus several steam carriage burners have other devices for accomplishing the end of producing gas for the burner before the main vaporizing tubes are heated.

An Auxiliary Coil Starting Device.—The starter used with the "Dayton" burner, already described, is shown in an accompanying cut. There, as may be seen, a small box, called a "starter box," is attached at one side of the burner. It contains a short

coil of tubing, into which liquid gasoline may be admitted by opening the valve marked, "starting valve." A few drops of liquid gasoline are then allowed to drip into the "starting cup," beneath the coil, and this, set on fire, will speedily generate sufficient gas to light the pilot burner, from which, in turn, the main burner may be kindled as soon as the vaporizing tubes are sufficiently heated. As soon as this point is reached the needle valve



Fig. 221.—Base of Boiler and Burner of the "Reading" Carriage, showing regulator and starter coil in position. A is the burner case; C, the hand-wheel controlling the valve to the mixing tube; D, the hand-wheel controlling the valve to the auxiliary vaporizing coil; E; F, the diaphragm regulator.

to the main burner, shown at the right hand of the starter box, is opened, admitting gas through the nozzle into the mixing tube. By closing this valve the main fire may be shut off, as desired, although the pilot light continues burning, until extinguished by shutting off its supply of gas, which is never modified in any way, being out of reach of the automatic regulator controlling the fuel feed to the main burner.

“Reading” Coil Starter.—A somewhat similar starting device, used on the “Reading” carriage, is shown in an accompanying figure, which gives a view of the base of the boiler, with burner and automatic diaphragm regulator attached. As may be seen, the gasoline, fed from the tank and passing down through one flue of the boiler, enters the burner apparatus at the point marked, *X*, where its inflow may be regulated by the needle valve, carried on the stem of the pressure head, as already explained. In order to start the burner a small amount of alcohol is poured into the cup, *E*, above which, as shown, is a coil of very small tubing. As soon as this coil is sufficiently heated, the valve, *D*, is opened slightly so as to admit gasoline into the tube. This, flowing around, is vaporized, and then being led off by the connecting tube to *C*, enters the mixing tube; sufficient gas being thus generated, before the alcohol is burned out, to supply fuel for lighting the burner. Since the flame, thus produced, is sufficient to vaporize the gasoline in the loop of tubing which passes directly over the burner, the valve, *C*, may soon be opened—this should be done slowly and carefully—and gas admitted to the mixing tube, shown at *G*, beneath the burner.

The design of this burner differs from many others in the fact that the mixing tube is thus placed below the structure instead of entering at the side, as shown in other figures. It may be readily seen that it consists of two tubes telescoped together, so as to permit of necessary variations in the distance between burner and connections. A slight slope from the centre serves to keep any liquid gasoline that may escape from entering the burner, where it might cause trouble. A pilot light is also attached to this burner, which, as in other types, burns continuously, reigniting the gas as soon as the flame goes out.

The Kelly Vaporizer and Burner.—The preliminary vaporizing device used on the Kelly burner, and also sold for attachment to others, is equally interesting in operation. A “generator” box, attached to the outside of the burner casing, encloses a portion of the tubing leading from the supply pipe and gasoline tank, and also attachments for the various valves. The bottom of this box contains a drip cup, and is arranged to open on a hinge, so as to allow of attaching an adjustable alcohol lamp, as shown in the accompanying cut. In order to begin the

process of vaporizing the fuel previous to lighting the burner, the movable drip cup and bottom of case is opened out, as shown at *C* in the cut, and the alcohol lamp, *K*, is hung beneath the opening. A flame is kindled in this lamp, and, after it has burned several minutes, the "sub-flame valve," *D*, is opened, and the lamp removed. At this point it is possible to ignite the vaporized gasoline at the opening of the "sub-flame valve," by applying a match through the small drop door shown near the top of the generator box. After the flame has burned about a minute more, the main fire valve may be opened, slowly at first,

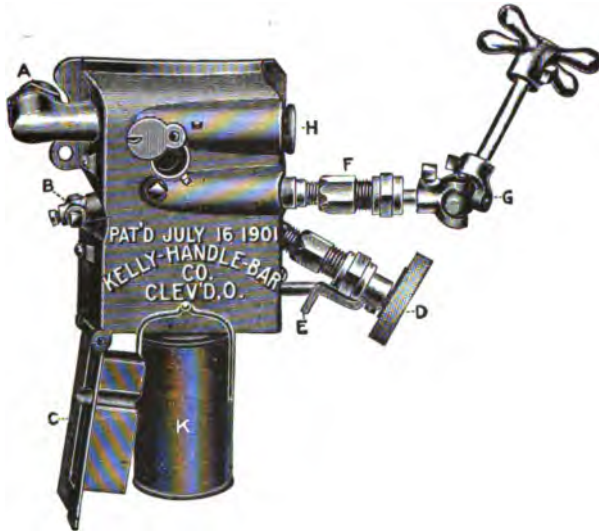

FIG. 222.—The Starter Box and Control Valve of the Kelly Burner. *A*, union joint to supply pipe; *B*, gas orifice leading direct to the main burner; *C*, drop drip cup and bottom of case; *D*, sub-flame valve; *E*, check on valve to prevent turning by vibrations of travel; *F*, packing nut on the main fire valve; *G*, knuckle joint to carry rod to seat; *H*, opening to screw on the diaphragm regulator; *K*, the alcohol lamp hung in position to start vaporizing and fire the burner.

in order that the burner and supply pipes may be thoroughly heated. As soon as the burner is thoroughly started the small door at the base of the generator is closed. In case the alcohol lamp has been lost, the drip cup formed on the inner face of this door, may be used for the preliminary vaporizing flame, by partially opening it and igniting the contained gasoline with a match. Gasoline may also be burned in the lamp in case no alcohol can be obtained.

The Kelly burner, designed for use with this generator system, is cast in one piece, the air and gas orifices being drilled through the upper face plate. This construction is efficient in preventing all warpage from heat.

An Automatic Gasoline Pump—As has already been stated, the average practice in American steam carriages is to store the gasoline in a tank under air pressure—generally between 30 and 45 pounds—which is sufficient to force it through the pipes leading to the burner, as already explained. This arrangement involves, however, that, so soon as the pressure falls below a certain point, it is necessary to raise it again, either with a hand pump, or with some make of steam air pump, such as has been described in the previous chapter. In either case the driver must constantly watch his air pressure gauge, and act accordingly. This fact has called the attention of several inventors to



FIG. 223.—The Kelly One-piece Cast Burner.

the desirability of constructing some kind of automatic pressure regulator, in order to save the driver constant exertion. One of the best known among such automatic devices is the Phelps gasoline pump, of which an elevation and sectional view are shown in accompanying figures.

Briefly described, the device consists of two parts: A plunger pump and a double receiving chamber, two upright cylinders. These two receiving cylinders are connected by a tube at their bases; one of them being closed at the top, the other, in communication with the inside of the pump barrel through the vertical tube and hand valve, as shown in the illustration. The pump proper is of peculiar design, having a simple plug piston without a stuffing box or any attempt at perfectly tight connections. The up-stroke of the piston rod is by the motion of the engine, attachment being made with a pin projecting from the

crosshead to the swinging link marked *C* in the cut. The down stroke is controlled by the spring, *S*, whose tension may be regulated by the adjusting screw, *N*, through the shank of which slides the piston rod, *P''*. In starting the gasoline circulation system, a plug is removed from the top of the left receiving cylinder of the two shown in the cut, and the cylinder is com-

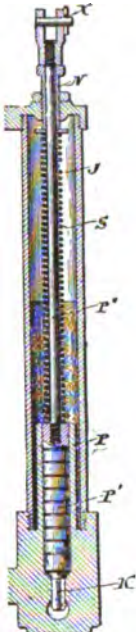

FIG. 224.

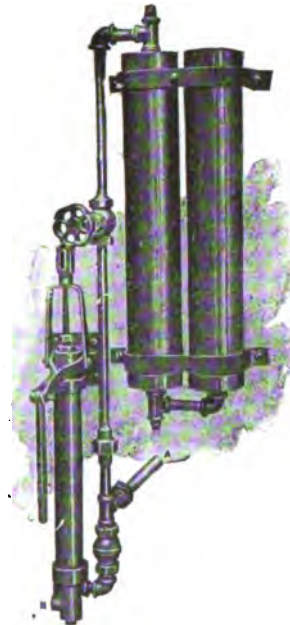

FIG. 225.

FIG. 224.—Section of the Phelps Gasoline Pump. *X* is the attachment for the operating lever; *N*, the adjusting screw for the spring; *J*, the cylinder; *S*, the spring mounted on the rod, *P''*; *P*, the slide for the plunger; *P'*, the plunger; *K*, entrance for gasoline. FIG. 225.—Phelps Gasoline Pump Feed Apparatus. *A* is the tube leading to burner; *B*, tube leading to gasoline tank; *C*, link for operating the pump by hand.

pletely filled with water. The pump is then started by hand, by means of a removable link and handle, working on the slotted head nut shown at the top of the piston rod. By this means gasoline is forced into the cylinder through the tube connecting to the pump, and acts to force the water through the cross-pipe, connected at the base, into the right-hand cylinder, where it con-

tinues to rise until the air cushion in that cylinder exerts a back-pressure equal to that of the adjustable spring in the pump barrel. The water also acts to prevent the air pressure cushion from coming into contact with the liquid gasoline and being absorbed thereby.

Since the barrel of the pump is in direct and unobstructed connection with the fuel supply tank, the level of the gasoline is the same in both, and, so long as the air pressure in the receiver cylinders is lower than that of the piston spring, gasoline is constantly pumped into the left-hand cylinder, as already stated, being fed thence directly to the burner. So soon as the pressures of air cushion and spring become equal, the feeding



FIG. 25a.—One Model of the "White" Steam Carriage.

of gasoline to the cylinder ceases, and the piston remains in an elevated position. Since, however, the capacity of the pump is many times greater than the requirements of the burner, it follows that, with any adjustment of the pressure, it must be out of action during a greater portion of the time, the gasoline being then fed under the air pressure in the receiver cylinder, until that falls again below the predetermined point.

Among the advantages claimed for this device are: The automatic regulation of the air pressure; the absence of by-pass valves, stuffing boxes, auxiliary pumps, hand air pumps; the fact that only one pint of gasoline is held under pressure at any one time, and, also, that exactly the required amount is being pumped, no more and no less.

CHAPTER SEVENTEEN.

STEAM AND ITS USE AS A MOTIVE POWER.

The General Situation on Steam Using.—In recognizing and applying practically the fact of the expansive energy of steam, Watt earned his title, inventor of the steam engine. All that has been done since his day is to still further enlarge on the principles applied by him: First, in the use of higher pressures; second, in such structural improvements as have rendered steam-using more economical and brought the engine to the high point of perfection it now possesses. All these improvements in the direction of enlarged efficiency have been made possible by a more perfect knowledge and closer observation of the laws governing the properties of steam at various temperatures and pressures. For, although exhibiting divergent properties in some particulars, steam may be treated and handled according to the general laws of “permanent” gases—those, such as air, oxygen, etc., which never pass into the liquid or solid states under the natural physical conditions maintaining on the earth’s surface.

On Steam and Other Gases.—In treating of gases in general, we must bear in mind that modern science has apparently succeeded in *artificially* producing liquid carbonic acid gas and “liquid air”; but these results, as is well known, are achieved by the production of certain physical conditions which occur *naturally* at no place on earth. While not digressing so far as to attempt a description of the laboratory processes employed, it is not too much to say that the results are achieved by combinations of extremely high pressures and extremely low temperatures, such as must necessitate complete readjustment of molecular conditions in the gases treated. Just as permanent liquids, such as water and mercury, assume the solid state at sufficiently low temperatures, and just as permanent solids, such as iron and flint, will assume the liquid state under sufficiently high temperatures, so “permanent gases” become liquids when the produced conditions are favorable. When, on the other hand,

the physical, or molecular, state of a substance is changed, the continuance of the new state depends upon the maintenance of the conditions in which it was produced. Thus, when water is changed into the vapor known as "steam," by the action of heat, it will return to the liquid state if the temperature is allowed to fall sufficiently. For this reason, it is necessary to maintain the cylinders of a steam engine at a temperature, at least, equal to that of the incoming steam. For this reason, also, it is, in general, impracticable to use steam of too high pressures—the pressure and temperature rise on a certain proportional scale—since,

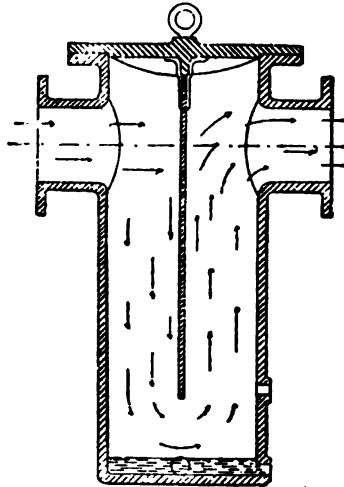

FIG. 226.—A Simple Form of Steam Separator. The steam, admitted through the port at the left of the figure, strikes against the screen in the centre of the chamber, thence following the direction of the arrows. Any condensation settles in the bottom of the chamber, whence it may be drawn off by the ports there shown.

as cannot be avoided, the difference between its temperature and that of the cylinder walls is so great that, during the period of exhaust, a large part of it is condensed; which means that the advantage gained will sooner or later be counteracted. This brings us to a consideration of the principles governing the generation and use of steam.

The Conditions of Steam Generation.—According to the current hypothesis on the constitution of matter, a very essential difference between the liquid and gaseous states of matter is that,

in passing from the first to the second, the constituent molecules of the substance are forced further apart. This seems to explain the fact that, when a liquid passes into a gas, it not only "evaporates" and disappears, but also fills a very much larger cubic space. Moreover, the amount of this expansion—as measured by the cubic content filled by the gas, as compared with that filled by the liquid—is in proportion to the heat under the action of which the water is vaporized. If then, a gas subjected to heat be confined in some receptacle, so that it cannot occupy the space properly belonging to it, it will show its tendency to assume that volume by exerting a pressure in proportion to the temperature in the receptacle. This is precisely what happens in a steam boiler. The steam, when liberated from confinement, will continue to exert a constantly decreasing pressure, until it has reached the volume properly resulting from its temperature, at which point the pressure will be that of the atmospheric air. It is this pressure, or natural effort to assume a greater volume—hence to displace movable obstacles—that is employed in the steam engine for producing motion and transmitting power.

The Forms of Steam.—In dealing with the general problems of steam engine operation, we must recognize two kinds of steam, or rather two conditions in which it is found and used. The first is that known as "saturated" steam, which may be defined as steam in contact with the water from which it has been generated, and which has absorbed and holds, as "latent heat," the full number of thermal units necessary to completely vaporize the liquid at the given pressure. The significance of the word, "saturated," is thus apparent—the steam holds *in solution* the full quantity of heat theoretically needed to produce and maintain it as steam. The second distinction of steam is "separated" steam, which signifies steam mechanically separated from the generating liquid, so that, when fed to the cylinder of the engine, it is perfectly *dry*. As the process of *separation* properly involves the constant maintenance of a high temperature, so that the process of condensation may be prevented, the dry steam continues to absorb heat, above the point required for this end, and thus becomes what is known as "superheated" steam.

When steam is properly separated and superheated, its expansion and other properties, so long as the initial temperature is

maintained, follows closely on the laws governing the actions of permanent gases. This is true only in a limited sense of steam that is still in contact with the generating liquid; since, not only does increase of heat within the generator, or boiler, tend to continue the process of steam production within small limits, but also because the steam holds in suspension a certain amount of unvaporized liquid particles. From either or both these causes, its coefficient of expansion is larger than that of dry steam. That is to say, it undergoes a greater increase in potential volume, as indicated by the consequent rapid proportionate increase in pressure, within the generator, or heated receptacle. Another point of difference—here it is that dry steam assumes the general properties of permanent gases—is that saturated steam, when a certain high point of pressure has been reached, tends to liquefy; hence also preventing the heated water from giving off any more vapor. Dry steam may not be condensed by pressure, so long as the temperature is not lowered. On account of this law of pressures, the evaporation of water by the sun, under atmospheric conditions, is less rapid than at high temperatures; also, water enclosed in a vacuum tube, where it is subjected to no pressure, theoretically, may be boiled, producing vapor, at the temperature of the human body (96° Fahrenheit).

The Law of Pressure and Volume of Gases.—The physical properties of gases in general are defined by two familiar laws—the first defining the degrees of volume and pressure at constantly maintained temperatures; the second, the ratio of expansion at a constantly increasing temperature. The first, known as Boyle's Law, states that THE VOLUME OF A GAS VARIES INVERSELY AS THE PRESSURE, SO LONG AS THE TEMPERATURE REMAINS THE SAME; OR, THE PRESSURE OF A GAS IS PROPORTIONAL TO ITS DENSITY.

This law has frequently been illustrated by the following experiment:

If we take a hollow cylinder, such as is used on steam engines, having a piston sliding airtight in its length, we will find that the contained air, or other gas, is compressed in front of the piston, as it is forced from one end toward the other of the base, and that this air, or gas, exerts a pressure which increases in ratio as the volume is diminished. This fact may be shown by inserting

in the wall of the cylinder a tube containing an airtight piston, upon which bears a spiral spring holding it normally, as at *A*; the pressure there being supposed equal on both sides of the piston, or equivalent to 15 pounds per square inch. If, now, the

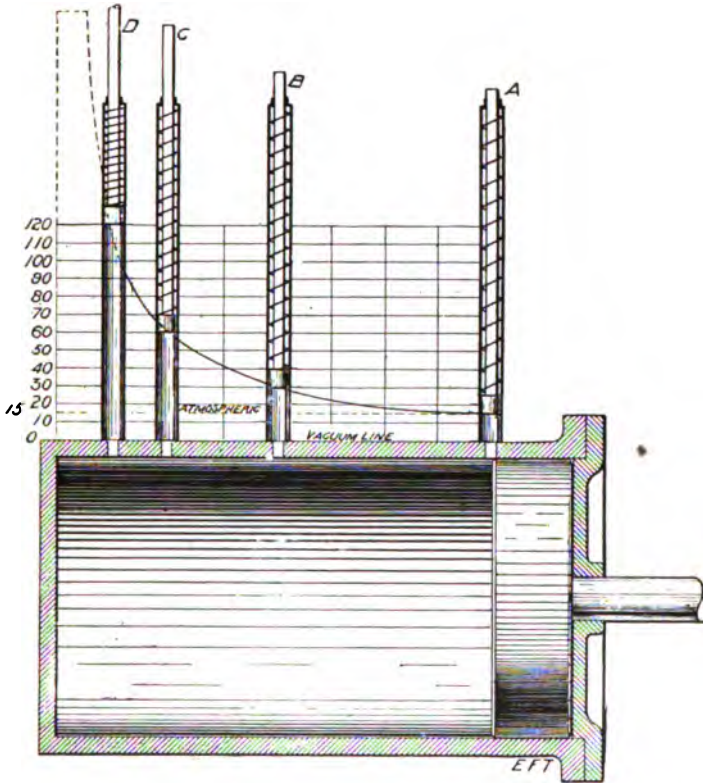

FIG. 227.—Diagrammatic Section of a Cylinder illustrating the compression and expansion of gases. This cylinder is filled with air at atmospheric pressure which represents a uniform 14.7 pounds to the square inch behind the piston, as shown by the position of the piston in the small cylinder, *A*. When the piston of the large cylinder is moved through half the length of the stroke, it shows 30 pounds pressure, as shown by the position of the piston in small cylinder, *B*; when at three-quarters stroke, 60 pounds, as shown by position of the piston, *C*; when at seven-eighths stroke, 120 pounds, as shown by position of piston, *D*. At full stroke it would be 240 pounds, the diagram behind the small piston giving the compression curve from 15 to 240.

area of this small piston be exactly one square inch, and the spring of such a tension as to move upward through one of the spaces between the lines on the diagram behind the large cylin-

der with each ten pounds of added pressure from below, the result will be as follows: When the piston of the large cylinder has been pushed through one-half its length, the depression of the spring in the smaller one will show that the pressure is just twice what it was at the start, or 30 pounds. At three-quarters the stroke it will show 60 pounds, and at seven-eighths, 120 pounds. If the four smaller cylinders be arranged in the wall of the cylin-



FIG. 228.—A Typical Steam Engine Indicator. It consists of a cylinder, shown at the right, within which works a piston under tension of a helical spring of predetermined strength. The rod attached to the piston carries a pivoted arm which works on the horizontal lever, shown at the top of the cylinder. This lever carries a pencil bearing against the rotatable drum, shown at the left. This drum is so arranged with a spring that it may be rotated by the pull on the attached string. A sheet of paper is wound on the drum and held in place by the spring clips. The steam pressure in the cylinder acting on the spring enables the pencil to mark; the indicator card being traced by the rotative movement of the paper drum.

der, as in the accompanying diagram, the difference in pressure at these several points may be graphically represented. Then a curve, drawn so as to pass through the centre of each of the smaller pistons, will give an accurate average of pressure for every position of the large piston. On the other hand, as under the operative conditions in a steam engine, it will represent the

“curve of expansion,” or the decrease in pressure from the moment of “cut-off,” when the inlet valve is closed to the end of the stroke, when the exhaust valve is opened. If, therefore, steam be fed into the cylinder at 200 pounds pressure per square inch, and the inlet be closed when the piston has traversed one-eighth of the stroke, the pressure will stand at 100 pounds on quarter-stroke; at 50 pounds on half-stroke, and, at 25 pounds on the point of completed stroke, which shows that it is expanded four times.

The Steam Engine Indicator and Its Records.—The action of the small cylinders containing springs and pistons, as just explained, very well illustrates the operation of the steam indicator. With the simplest form of this instrument these cylinders are identical, except for a pencil carried on the uppermost end of the piston rod, and bearing upon a suitable tablet, which is moved backward and forward with the stroke of the steam piston. This is done by attaching the long arm of a reducing lever to the crosshead, and the shorter arm to a link-bar which holds the card, or tablet, to be inscribed. The several forms of the indicator most often used at the present day have a rotatable drum, which is attached by a cord to the short arm of the reducing lever, so as to be turned in one direction; being moved in the other direction by a contained spring, which rewinds the cord, so soon as the lever arm moves backward. Thus the records of a great number of strokes may be taken on one sheet of paper—wound about the drum and held on by clips—and there is no danger of interrupting the process.

The records thus made, by knowing the dimensions of the cylinder and the tension, or resisting strength, of the steam-actuated spring, may be very accurately calculated for the entire cycle of the engine.

The Temperature and Volume of Gases—While it will be hardly necessary to go into minute details regarding the laws of gases, it will be well to briefly state the ascertained conditions by which the volume is increased while the pressure remains constant. Thus the “second law of gases,” called Charles’ or Gay Lussac’s law, states that AT CONSTANT PRESSURE THE VOLUME OF A GAS VARIES WITH THE TEMPERATURE, THE INCREASE BE-

ING IN PROPORTION TO THE CHANGE OF TEMPERATURE AND THE VOLUME OF THE GAS AT ZERO. By actual experiment it has been ascertained that a gas increases on a ratio of 1-493d part of its volume at 32° Fahrenheit, with each additional degree added to its temperature. This places the "absolute zero," or the point at which a gas would assume its greatest possible density at — 461°, Fahrenheit, or — 273°, Centigrade. A higher degree of temperature within a closed receptacle, like a steam boiler, involves a higher degree of pressure there, and in the cylinder to which the steam is fed, because of the tendency to assume a greater proportional volume, although, because of the several inevitable sources of lost heat, no rule applies completely in the practical operation of the steam engine.

Determining the Temperature From the Pressure.—Tables showing the "properties of saturated steam," as far as regards the volume, temperature, pressure, etc., are given in the appendix, but the determination of these points is a matter of some exactness of calculation. In order to explain the process for a given diagram, say like the one already found for a cylinder expanding 1-10 pound of steam from 120 pounds per square inch pressure to atmosphere, we can do no better than quote from Forney's "Catechism of the Locomotive." He says: "If the piston stand at the point shown in the previous figure, and 1-10 pound of water be put into the cylinder, and heat be applied to it, it would be necessary to heat the water to 212° before it would boil. To represent this heat, the vertical line, *JK*, is extended below the horizontal line, *AJ*. To heat 1-10 pound of water to 212° takes 21.2 units of heat,"—since one unit of heat is required to raise one pound of water at 39° Fahrenheit to one degree above—"which is laid off from *J* to *J'* to the scale represented by the horizontal lines. But, as is shown in the table in the appendix, after the water begins to boil, 96.6 more units of heat must be added to it to convert it all into steam of atmospheric pressure. This number of units of heat is, therefore, laid off from *J'* to *J''*. If the piston be moved to *E*, the middle of the cylinder, and 1-10 pound of water is again put into it, and it is all converted into steam, it will have a pressure of 30 pounds per square inch, as it occupies only half the volume that the same

quantity of steam did before. To make water boil under a pressure of 30 pounds, it must be heated to a temperature of 250.4°, which in this case will require 25 units of heat, which is laid down from *E* to *E'*. To convert the water into steam, after it begins to boil, will require 93.9 more units of heat, which is also laid down from *E'* to *E''*. In the same way the total heat to boil and convert 1-10 pound of water into steam at 60 and 120 pounds pressure, as shown in the appendix, is laid down on *C C''* and *B B''*, and the two curves, *B' C' E' J'* and *B'' C'' E'' J''*, are drawn through the points which have been laid down. The vertical distance of the one curve from *A J* represents the heat units re-

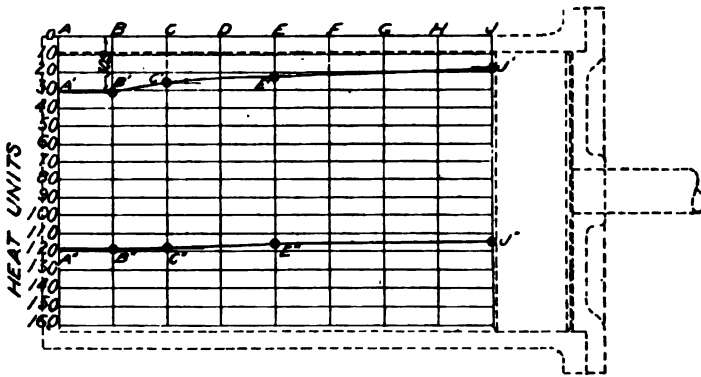

FIG. 230.—Diagram showing the number of heat units required to raise one-tenth pound of steam under the various pressures indicated by the position of the piston, at full stroke, half stroke and seven-eighths stroke. In using this diagram it is necessary to note that the heat units are calculated from -1° Fahrenheit, instead of from 32° , as is the general rule.

quired to boil 1-10 pound of water at the pressures indicated by the curve in the previous figure, and the vertical distance of the second curve from *A J* represents the total units of heat required to convert 1-10 pound of water into steam of a volume indicated by the horizontal distance of any point of the curve from *A A''*, and when pressure is indicated by the expansion curve above. This curve and the heat diagram may be very conveniently combined by adding the latter below the vacuum line of the former. The relation of the volume pressure and total heat is thus shown very clearly."

The Practical Effects of Steam Expansion.—A principle recognized as fundamental in steam engine practice is that the work-producing, or dynamic, property of a gas depends solely upon its temperature. This is, substantially, a statement of Joule's law, which compares the temperature of a gas, enabling it to exert a certain amount of power, to the stored energy represented in a body of a certain weight raised to a certain height above the ground. The body, in falling under the force of gravity, obtains a certain degree of acceleration, constantly increasing, by which the weight falling through the given distance is transformed into a force capable of producing a commensurate effect of impact on reaching the earth's surface. This potential energy of a substance, represented either by an acquired temperature or some analogous physical condition, which, under favorable circumstances, would enable the production of a definite amount of work, is known as "entropy." Could the whole power of a heated gas be realized in its expansion—which is to say, could its expansion be perfectly "adiabatic," or "isentropic," involving neither gain nor loss of heat in the process—we should have a theoretically perfect expansion curve on the practical steam engine. This is impossible, however, with the best arrangements yet contrived. Hence it is that the expansion curves of all engines fall far below what is demanded by theory from the original temperature and pressure of the steam, which involves that the final volume and the actual work accomplished are correspondingly diminished.

To quote from an authority on steam engines, "as we cannot take into consideration all the conditions which govern and modify the cycle of any motor, the usual practice is to calculate the power on the assumption that all theoretical conditions are complied with, and then modify the result by a certain coefficient of efficiency which practice has established for the particular type of motor under consideration."

The Indicator Diagram and the Engine Cycle.—The operative efficiency of an engine may be very well determined from the indicator diagram, which gives a pictorial representation of the internal conditions throughout the entire cycle of operations. As given by a noted authority, already quoted, the diagram tells us eleven different things essential to be known:

(1) It gives the *initial pressure*, or the pressure at beginning of the stroke. (2) It tells whether the pressure is increased or diminished during the period of admission. (3) It gives the point of cut-off, when the valve is closed and expansion begins. (4) It indicates the rate and pressure of expansion during the whole period of expansion. (5) It gives the "point of release," when the exhaust is opened. (6) It shows the rapidity of the exhaust. (7) It gives the degree of back-pressure on the piston, due to the exhaust having closed, preventing further expansion. (8) It shows the point of closing the exhaust. (9) It shows the *compression* of the residual steam in the clearance after closing the exhaust. (10) It gives the mean power used in driving the engine. (11) It indicates any leakage of valves or piston.

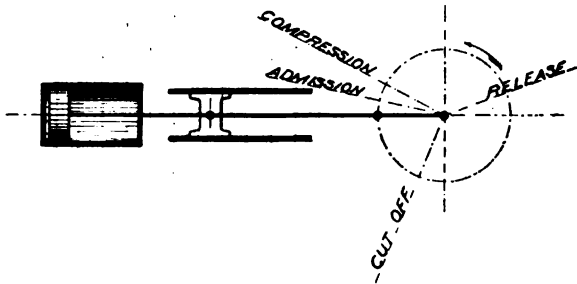

FIG. 230.—Diagram of the Cycle of a Steam Engine. The dotted circle indicates the path of the crank; the arrow, the direction of rotation. The admission begins a little before the completion of the stroke; the cut-off is set somewhat less than quarter-stroke; release, or opening of the exhaust, at somewhat over half stroke; closing of the valve at the point marked "compression," after which the steam behind the piston is compressed in the clearance until the opening of the inlet valve.

The cycle of operations in a steam cylinder consists of four stages: (1) Admission; (2) expansion; (3) exhaust; (4) compression.

The indicator card (Fig. 232), which is drawn to illustrate the average conditions in an efficient low-pressure cylinder, shows the pressures at various points in the cycle. At line 1, the pressure of the steam in entering the cylinder is shown rising from a point of no pressure to 57 pounds, the curve in the vertical line indicating a back pressure of at least three pounds at the beginning of the admission, as shown by the fact that, at line 2, the pressure stands at 60 pounds, and, at line 3, just after the closure of the admission valve, at 58 pounds. The engine from which

this diagram is taken has its cut-off at a point somewhat less than quarter stroke. After the point of cut-off, the pressure falls steadily, as indicated by the droop of the expansion line, until at ordinate, 10, it shows 13.75 pounds to the square inch. At this point the exhaust valve is opened and so continues during the return stroke, while the steam pressure is being exerted on the opposite face of the piston, until the pressure on that side of the piston is reduced to 3 pounds, absolute.

The second diagram, an actual tracing from the intermediate cylinder of a triple expansion engine, gives a good idea of the appearance of an average card for a double-acting cylinder. As will be seen, the figure is nearly duplicated in reversed position.

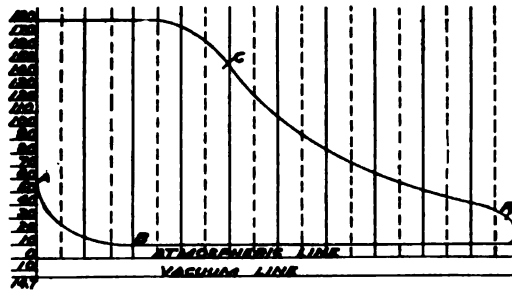

FIG. 231.—The Cycle of a Steam Engine, as shown by the Indicator Card. On this tracing, the admission is shown from A to C; the cut-off at C; the expansion curve from C to R; the release, or opening of the exhaust, at R, exhaust continuing from R to B; closing of the exhaust valve at B; compression of the residual steam in the cylinder clearance, from B to A. The figures on the left-hand vertical line indicate the gauge pressures. This diagram shows the operative conditions in a "high-pressure" cylinder; Fig. 232, in a "low-pressure" cylinder.

It would be identical if the cycular conditions were perfect, and if the valve were perfectly adjusted.

Reading an Indicator Diagram—The simplest method of reading a diagram is to rule equidistant lines from the vertical initial pressure line, so as to divide it into ten equal parts, or areas. Ordinates, indicated by the dotted lines, are then ruled between these, and given a value equivalent to the average of pressure represented by the lines on either side, as indicated by the point of contact with the admission line and the expansion curve. Thus in the single "low-pressure" diagram the three ordinates ruled on the admission line have each a value of 77 pounds, which represents 80 pounds less 3, back pressure. The

fourth, touching the expansion curve at the point of 57 pounds, is marked 54 pounds; and so on to the tenth ordinate. The sum of the ordinates (449 pounds) divided by this number (10), gives 44.9 pounds per square inch as the *mean effective pressure* throughout the cycle, or the average of efficient pressure exerted on the piston, while the actual pressure is undergoing a steady fall from 77 pounds to 18 pounds, absolute. In similar fashion the diagram for both strokes is ruled off and estimated, the figures at the top of the figure indicating the cycle of pressure changes for the right-hand stroke, those at the bottom the cycle for the left-hand, or return, stroke.

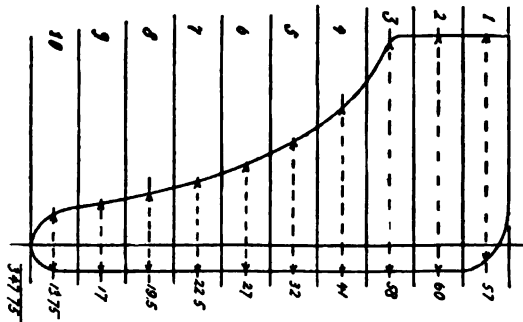

FIG. 233.—Ideal Indicator Card for a low-pressure, or condensing, engine, showing the fall of pressure below the atmospheric line. As shown in this cut, the effective steam pressures at the various points in the cycle vary between a maximum of 60 pounds and 13.75 pounds to the square inch before the opening of the exhaust. The sum of the ten figures for pressure is 347.75, which, divided by 10, gives 34.775, as the expression for the mean effective pressure. Because of the use of a condenser to reduce the back pressure, this figure represents the actual effective working pressure less 3 pounds, as indicated on the diagram.

Pressures and Temperatures of Steam.—In order that the steam-carriage driver may understand by a glance at the gauge what temperature is in his boiler, the following table of ordinary pressures is given :

Pressure.	Temperature.	Pressure.	Temperature.	Pressure.	Temperature.
15 lbs.	— 212° F.	55 lbs.	— 285° F.	100 lbs.	— 330° F.
20 lbs.	— 228° F.	60 lbs.	— 294° F.	105 lbs.	— 333° F.
25 lbs.	— 241° F.	65 lbs.	— 299° F.	120 lbs.	— 343° F.
30 lbs.	— 252° F.	70 lbs.	— 304° F.	135 lbs.	— 352° F.
35 lbs.	— 261° F.	75 lbs.	— 309° F.	150 lbs.	— 362° F.
40 lbs.	— 268° F.	80 lbs.	— 313° F.	165 lbs.	— 369° F.
45 lbs.	— 275° F.	85 lbs.	— 316° F.	180 lbs.	— 375° F.
50 lbs.	— 282° F.	90 lbs.	— 322° F.	195 lbs.	— 383° F.

Power Estimates from the Steam Consumption.—Referring to the tables on the properties of saturated steam, given in the appendix, we find a means of determining the power capacity of the engine from the diagram. Thus, taking the initial pressure in the cylinder, 77 pounds, we find it equivalent to a temperature of 309.3°, Fahrenheit; taking the final pressure, 18 pounds, we find it equivalent to a temperature of 222.4°, Fahrenheit, and, the mean effective pressure, 44.9 pounds, to about 274°. This temperature represents about 1197.4 heat units per pound of water, which is equivalent to 924,392.8 foot-pounds; estimating 772 foot-pounds per thermal unit. Therefore, a cylinder, such

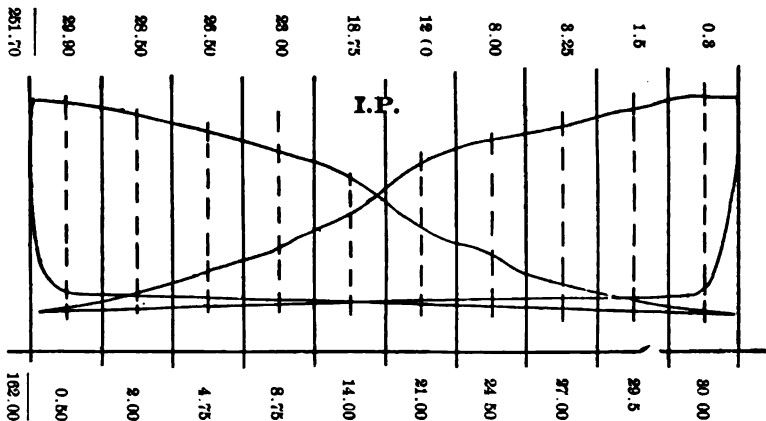

FIG. 233.—Card from the intermediate pressure cylinder of a triple expansion engine, with figures for pressure at the various points in the cycle. This is an average good diagram for a double-acting cylinder. The mean effective pressure is found, as follows: $151.70 + 162 = 313.70$. Divide this by 20, we have 15.685 lbs. — M. E. P.

as is mentioned in the quotation from Forney, which can contain one-tenth pound of steam per stroke at a mean pressure of, say 44.9 pounds, as per above diagram, will develop at 200 revolutions, or 400 strokes, per minute, a horse-power shown by the following formula:

$$\frac{92439.28 \times 400}{33,000} = 1120.48.$$

Elements in Estimates on Horse-Power.—As a moment's reflection will readily reveal, the elements entering into the estimate of an engine's horse-power are the effective temperature

of the steam, as indicated by the mean pressure throughout the stroke; the content of the cylinder, as indicated by the length of the stroke and the area of the piston; and the number of revolutions per minute. The product found by multiplying these factors will give the number of foot-pounds made available; which expression, divided by 33,000, gives the indicated horse-power.

The denominator, 33,000, expresses the number of foot-pounds per minute in a horse-power. Thus, a horse-power is such a force as can lift a weight of one pound through 550 feet in each second, or, such as can lift a weight of 550 pounds through one foot in each second. This force constantly exerted through one minute, or sixty seconds, can lift 33,000 pounds through one foot, or one pound through 33,000 feet. Since, however, the action involves motion, it is cumulative in both time and space; requiring an increased area of operating surface, or an increased length of time, or both, to accomplish work in excess of the figures given. Thus, an engine exerting precisely one effective horse-power can raise 10 pounds through only 3,300 feet per minute, or 55 feet per second, and requires 10 minutes or 600 seconds, to raise 330,000 pounds through the vertical distance of one foot. To so enlarge the capacity of an engine that it can do ten times the indicated amount of work in a given space of time, or, so that it can do the indicated amount of work in one-tenth that given time, involves that the cubic content of its operating chamber, or cylinder, be proportionally increased, in order that ten times the amount of steam may be utilized in a given time, or for the accomplishment of a given work at each stroke of the piston. For it is evident that a mean effective pressure of 45 pounds per square inch means 90 pounds available pressure with a piston area of two square inches; 180 pounds available pressure with a piston area of four square inches, and 22.5 pounds available pressure with a piston area of 1-2 square inch.

First Rule for Calculating Horse-Power.—On the basis of these evident principles, two simple rules may be derived for calculating the indicated horse-power. This, however, is always in excess of the actual efficient horse-power, as will be subsequently explained. While there are numerous formulæ for

determining this point, one of the most familiar is as follows:

(a) Find the area of the piston by multiplying the square of a radius in inches by 3.14159 (ratio between circumference and diameter).

(b) Find the pressure *in pounds* on the piston by multiplying the area by the mean pressure per square inch.

(c) Find the length *in feet* traveled by the piston per minute, by multiplying the length of the stroke *in feet*, or *fractions of a foot*, by twice the number of ascertained revolutions of the crank shaft per minute. This equals the number of strokes per minute for a double-acting cylinder.

(d) Find the foot-pounds available during the given space of time (one minute) by multiplying the pressure, *in pounds*, by the length traveled by the piston, *in feet*.

(e) Find the I. H. P. (indicated horse-power) by dividing this last product by 33,000.

The formula is:
$$\frac{P L A N}{33,000} = \text{I. H. P.};$$

P being equivalent to the M.E.P. (mean effective pressure) in pounds per square inch.

L being equivalent to the length of the stroke in terms of feet.

A being equivalent to the area of the piston in square inches.

N being equivalent to the number of strokes of the piston, or twice the number of revolutions of the crank-shaft, per minute.

The element of speed, as expressed in terms of strokes, or revolutions, per minute, is important, and fundamental, in estimates on power, since, as must be evident from what has already been said, the superior power-capacity of one engine over another consists principally in being able to do, for example, ten times the work in a given time, or to do the same work ten times as fast. Therefore, an engine that can propel a given mass and weight of machinery at 300 revolutions of its crank-shaft and fly-wheel, per minute, is evidently three times more powerful than another engine which can move the same mass and weight of machinery at only 100 revolutions per minute. Consequently, in forming the expression for the horse-power ratio of any given engine, the other essential factors of the numerator are to be increased, as the number of times per minute the engine performs its complete cycle.

The Mean Effective Pressure.—The mean effective pressure (M.E.P.) may be calculated from the indicator diagram, as above explained, but it may also be found by knowing the initial steam pressure in the cylinder and the point of cut-off. Thus, as given in the table, entitled, "To find the M. E. P. of a Steam Engine," included in the appendix, we may take any initial pressure given in the first column, and follow the horizontal distance to the column corresponding to the number of times the steam is expanded. Thus if the initial pressure be 150 pounds, and the steam be expanded five times, we have a mean effective pressure of 78.30 pounds absolute, which, if the engine exhausts to atmosphere, must be diminished by 15, representing the back-pressure, giving 63.30.

To apply the formula given above to the calculation of an engine of, say, three inches piston diameter; four inches stroke; 63.3 mean effective pressure, and 200 revolutions per minute, we have:

$$\frac{63.3 \times .333 \times 7.0686 \times 400}{33,000} = 1.80 \text{ I. H. P.}$$

In this expression 63.3 represents the M.E.P. calculated as above; .333, the fractional expression in terms of one foot for four inches; 7.0686, the area of a circle whose diameter is three inches; and 400, the number of strokes per minute for a double acting cylinder at 200 revolutions of the crank-shaft. The result is, approximately, two horse-power, which, multiplied by 2 to represent the two cylinders, as in most steam carriage engines, gives an indicated horse-power of about four, which is fairly representative.

Second Rule for Calculating Horse-Power.—A second rule for computing the horse-power of a steam engine gives the product of:

- (a) The square of the piston diameter.
- (b) The length of the stroke in feet.
- (c) The number of strokes per minute.
- (d) The M. E. P. per square inch.
- (e) **The constant, .0000238.**

Computing for the engine mentioned above, we have:

$$9 \times .333 \times 400 \times 63.3 \times .0000238 = 1.80 +.$$

CHAPTER EIGHTEEN.

CONSTRUCTION AND OPERATION OF A STEAM ENGINE.

The Slide Valves of a Steam Cylinder.—The mechanism by which steam is admitted to the cylinder of a steam engine, consists of a sliding valve of such a shape as to open communication from one end of the cylinder to the exhaust, while the other end of the cylinder is receiving steam direct from the steam chest. This will be readily understood from the accompanying illustration. There are two kinds of valves in common use on steam carriage engines; the common D-valve shown herewith, and the piston valve, as shown in a number of engines hereafter to be described. The object obtained by both valves is the same, although the piston valve is preferred by many engineers because it is better balanced in its operation, and also because, owing

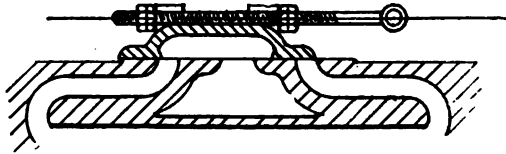

FIG. 284.—Slide Valve of a Steam Engine, showing position after cut-off of steam from right-hand end of cylinder, the exhaust continuing full from the left-hand end.

to its packing rings, it is less liable to leakage. However, with a well-made valve of either variety, the ends of economy and durability are equally maintained.

The Piston of a Steam Engine.—The piston of a steam engine, as shown in an accompanying figure, usually consists of a flattened cylindrical piece of slightly smaller diameter than the bore of the cylinder, in which it slides. Steam-tight contact is obtained by springing packing rings into grooves cut in its circumference. The accompanying cut shows three such rings sprung on the piston. The steam admitted through the inlet valve bears upon one face of the piston, and by its expansive energy causes the piston to move. As may be understood,

however, from the fact that the piston rod is attached to one face of the piston, the bearing surface of the steam is decreased as the area of the rod. This item must be considered in exact calculations on engine horse-power, although for ordinary purposes it is negligible.

The Operation of the Slide Valve.—The valve controlling the inlet and exhaust ports of a steam cylinder is made of such length that, when in mid-position, it completely closes both inlet ports, neither admitting steam nor allowing it to be exhausted. In the valve shown on the accompanying sectional cut, it is evident that, supposing it to be moved either to the right or to the left, the communication will be opened with the exhaust port on the one side, sooner than with the steam chest on the other, thus permitting with a very slight

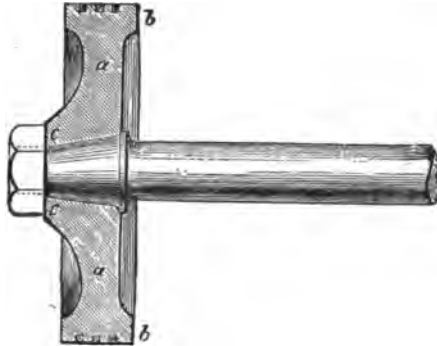

FIG. 235.—The Piston of a small double-acting steam engine, showing method of connecting the piston rod, and the position of the packing rings. The parts are: *a, a*, the body of the piston; *b, b*, the circumference bearing the packing rings; *c, c*, the central boss receiving the coned end of the rod.

variation in the length of the stroke, that the exhaust remain open even while the inlet of the steam to the opposite face of the piston is cut off. In calculating the operation of cylinder valves there are two important items to be considered—the “lap” and the “lead” of the valves. The “lead” of a valve is the amount by which the steam port is open when the piston is at the beginning of the stroke. According as this is more or less the inlet of steam is varied through the several fractions of the stroke. The lead may be changed either by cutting down the lap of the valve, or by varying the stroke length of the valve and its rod.

The "lap" of a valve indicates any portion added to the length of the valve, so as to increase the portion of the stroke during which the ports are covered, beyond that length which is positively required to insure the closing of all ports when the valve is in mid-position. There are two kinds of "lap." The "outside lap" is any portion added to the length of the valve beyond that necessary to cover both inlet ports at mid-position. The "inside lap" is any portion added to the hollow or inside portion of the D-valve, over and above what is necessary in order to cover the inner edges of the steam ports, and to close the exhaust port from both sides when the valve is in mid-position.

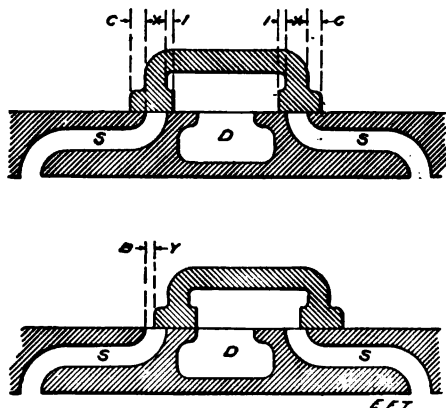

FIG. 236.—Diagrams illustrating the "Lap" and "Lead" of a Steam Cylinder Slide Valve. In both sections, S and S are the steam ports, and D the exhaust. The upper section illustrates the "laps" of a valve; the space between the lines C and X giving the "outside lap," and between the lines X and I the "inside lap." The lower section illustrates the "lead" of a valve; the space between lines B and Y showing the opening of the valve at the beginning of the right-hand stroke.

As already suggested in the previous chapter, the exhaust valve is closed somewhat before the completion of the stroke, thus allowing the residual steam in the clearance to be compressed somewhat before the opening of the inlet. The most important result obtained in this manner is that the compression produces a temperature, as near as possible, the same as that of the incoming steam, which is an efficient factor in heat economy, although producing some back pressure that slightly reduces the M. E. P. Another important consideration is that a soft cushion is thus provided for the forward-moving piston,

which acts to save unnecessary wear on the crank and other moving parts, as is most essential in a small engine.

From the operations of this valve and cylinder, it must be evident that its stroke cannot be equal to that of the piston in the main cylinder. It cannot, therefore, be operated direct from the crank-shaft of the engine. Accordingly, the most usual method of operating the steam valves of an engine is by an eccentric on the main shaft, which operates the valve rod. This device may be either a single or double eccentric, according to the requirements, but when ready reversal of the engine's motion is desired, as in the case of a locomotive or marine engine, the double eccentric with the shifting, or Stephenson, link is most generally used.

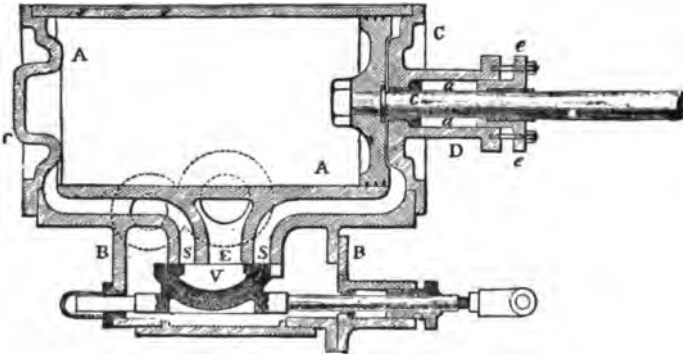

FIG. 237.—Section through a Steam Cylinder and Valve Chest, showing parts. A is the cylinder; B, the steam chest; C and C, the cylinder heads; D, the stuffing box; a and a, the packing gland; c, the piston rod; E, the exhaust port; S and S, the steam ports; V, the slide valve; e, e, the packing gland, held in place by screws in this engine.

The Eccentric Gear and Link Motion—An eccentric is a circular piece of metal, a wheel in fact, except for the fact that instead of turning upon its centre, it is attached to the shaft at a point near its periphery. Around this disc-shaped piece is attached a circular metal strap, joined to a rod, which may be either attached direct to the valve rod, or, where two eccentrics are used, to one end of the swinging link. The link is an arc-shaped metal piece, usually made with a slot through the greater part of its length. It is hung from its centre point to a link-saddle, which, as shown in the accompanying figure, is bolted to either side of the slot and is suspended from the link-hanger

either above or below. Within the slot is set a link-block, as it is called, so that it may slide in the slot through its entire length, whenever the link is raised or lowered on its hanger. To this link-block is attached the valve rod. The general arrangements of the link motion may be understood from the accompanying illustration.

The Operation of the Shifting Link.—As already stated, the link motion was originally intended only for reversing the engine, which is to say to enable the steam to be cut off from

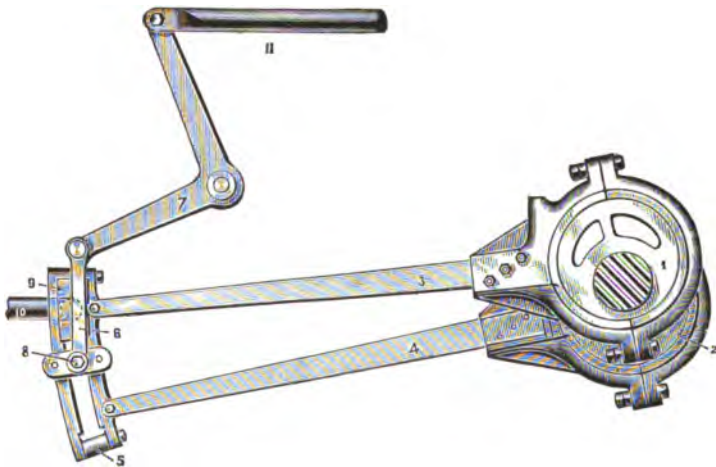

FIG. 238.—Diagram of the Link Motion and Eccentric Gear of a Steam Engine. The parts shown are: (1) backward eccentric; (2) forward eccentric; (3-4) eccentric rods; (5) slotted shifting link; (6) link hanger; (7) reversing arm; (8) link saddle pin; (9) link block; (10) valve stem; (11) reach rod. The position shown in the cut indicates that the backward eccentric is in gear which gives a reverse motion to the engine.

one side of the cylinder and admitted to the other, whenever desired, by shifting the motion of the slide-valve. In addition to this function, however, the link motion provides a means for using the steam expansively, when cutting off the supply of live steam at any earlier point in the piston stroke, which act is accomplished by reducing the travel of the slide-valve. When the link-block is at one end of the slot, the valve receives the motion of the eccentric rod attached to that end of the link, and, consequently, since the links are set at angles somewhat greater than 180 degrees, the one is for the forward motion of the en-

gine, the other for the reversed motion. In the accompanying illustration, the backward eccentric is in gear. By this means, whenever the link is shifted, only the eccentric whose rod stands opposite the link-block imparts its motion to the valve. The other is practically inactive, except for imparting a slight oscillatory motion to the link, which in general practice is negligible. The link which is in gear acts, in reality, like a short-throw crank, or as if it were a single eccentric. From the position of "full-gear"—that is, when the link-block stands at either end of the slot—the travel of the valve may be more or less modified until the centre point of the slot is reached, which point is called

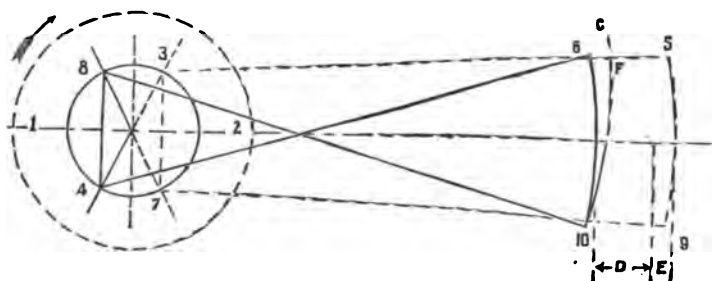

FIG. 289 —Diagram of the Operation of the Link Motion. The centres of the two eccentrics being at 4 and 8, the crank pin at 2, the link at mid-gear, the eccentric rods will be indicated by the full lines, 4-6, 8-10. When the crank pin is at 1, the centres of the eccentrics will be at 8 and 7, and the positions of the rods on the dotted lines, 3-5 and 7-9. The distance, D, indicates the vertical distance between the centres of the eccentrics in the full and dotted-line positions. If from the centre, 8, with the rod as the radius, an arc be drawn to F, the distance, C, shows the position of the link if both rods were "open" with the crank at the cylinder end, 2, instead of at the opposite dead centre, 1. The distance, C, is equal to the distance, E, and the total distance (D + E) that the valve moves is twice the lap, plus twice the lead, plus the distance, or angularity, occasioned by the rods being crossed, when the crank is on the cylinder end dead centre, 2, becoming opened when the crank is at dead centre, 1.

mid-gear. There the travel in either direction is so slight that the steam and exhaust ports of the cylinder are not opened. This is in reality the "dead point," and further shifting of the link in the same direction begins the process of reversing by increasing the travel of the valve in the opposite direction. When at mid-gear the valve partakes of the motion of both eccentrics equally, but since their motion describes a cassinian, or flattened figure 8, laid on its side, of which the link-block is the centre, the motion is at its point. Although this general movement is continued so long as the engine is in operation, it is reduced to practical zero at the link-block set at full gear.

When the link is at full gear, the travel of the valve is equal to twice the throw of the eccentric, less the angularity of the eccentric rod. When the link is at mid-gear, the travel of the valve is equal to twice the lap and lead of the valve, plus twice the angularity of the eccentric rods. By the angularity of the

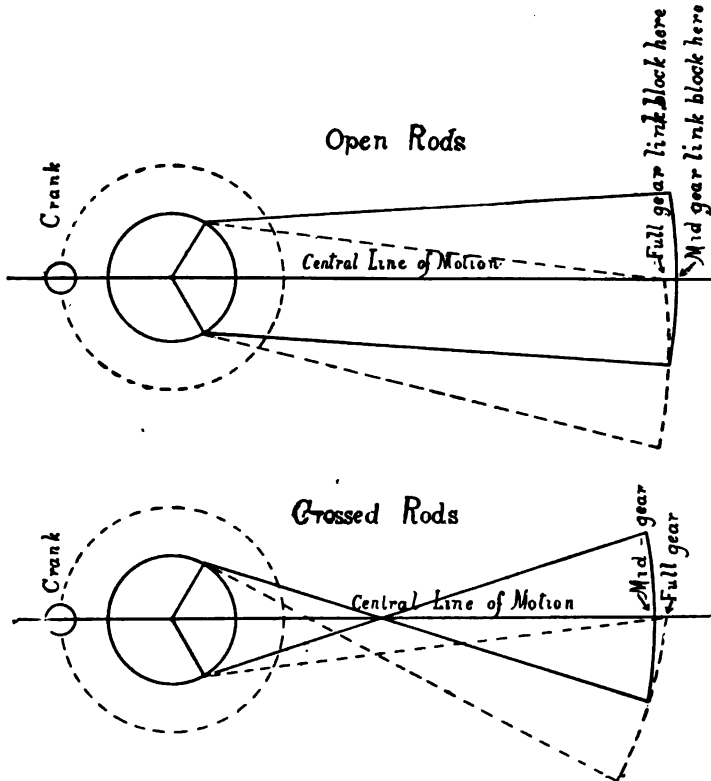

FIG. 240.—Diagram showing the positions of the eccentric throws and rods at full gear and mid-gear, when the rods are "open" and "crossed" with the crank at the forward dead centre, marked 1 in the previous cut.

eccentric rods is meant the distance the centre of the link or the valve would move, should the rod of the geared eccentric be disconnected from it and connected with the other link. The amount of the angularity thus, of course, varies with the length of the rods. The shorter the rods, the greater the travel of the

valve, owing to the crossing of the rods during a one-half revolution of the crank. When the eccentric rods of a direct connected link motion are disposed as shown in the accompanying diagram, and the link motion and gear of the crank is at the dead point marked 1, the rods are said to be open. If they are disposed as shown by the dotted lines in the same figure, and the crank is at the dead point, 2, they are said to be crossed. There is, however, an important difference in the operation involved in the relative positions of the rods to the crank, as shown by the travel of the steam valve, since rods which are open at the specified point give an increasing lead from full-gear towards mid-gear, while rods crossed at that point give a decreasing lead in the same direction. Variation of lead from full-gear

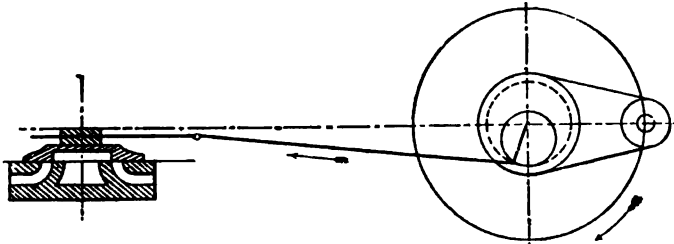

FIG. 241.—Diagram with a single eccentric, illustrating the position of the steam valve, when the crank pin is at the forward dead centre, the throw of the eccentric being at an angle off the perpendicular. The arrows show the direction of motion.

to mid-gear is due to the curvature of the link-arc, and for a link of short radius is more pronounced than for a link of longer radius. As a general rule, the radius of the link is equal to the length of the eccentric rod.

The Practical Expansion Ratio for Steam.—In the practical operation of the steam engine, as most generally understood, the steam is fed direct from the boiler to the cylinder, there expanding from its original pressure to a number of volumes, proportioned to the length of the stroke and point of cut-off. The idea of cutting off the supply of steam before the completion of the stroke, and making use of its expansive energy during the remaining portion, constitutes, as we have seen, the first improvement made by Watt. According to Boyle's Law, already quoted, the pressure of the steam is in exactly inverse ratio to

its expansion, which is to say that when a body of steam is expanded to twice its original volume, it should have just one-half its original pressure, so long as the temperature be constant. This law is never exactly followed in practice, the general rule, as shown by indicator diagrams, being a rapid fall during the first period of expansion and a more gradual one in the latter

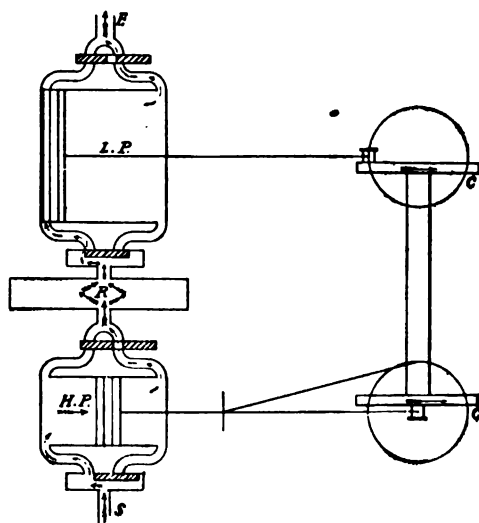

FIG. 242.—Diagram of a "Cross Compound" Steam Engine. The cranks, C and C', are at 90°. The high-pressure steam port is at S; the H. P. exhaust to L. P. cylinder at R, and the exhaust to atmosphere from the low-pressure cylinder, at E.

period. However, for general purposes, the law is assumed to be perfectly operative, and the rule for calculating the pressure at any point of expansion, is to divide the original absolute pressure by the number of times it has expanded. Thus, steam fed to a cylinder at 100 pounds gauge, or 115 pounds absolute, has a pressure of $57\frac{1}{2}$ pounds when expanded to two volumes, a pressure of $38\frac{1}{3}$ pounds when expanded to three volumes and a pressure of $28\frac{1}{4}$ pounds when expanded to four volumes. It would, therefore, require as many expansions to reduce the gauge pressure of 100 pounds to atmosphere, as 15 is contained in 115, which is 7 $\frac{2}{3}$ times. If the flow of steam to the cylinder be cut off at one-half stroke, it has been ascertained by numerous experiments, that its efficiency will be increased 1 $\frac{1}{7}$

times what it would have been if the steam at the same point has been released into atmosphere. The following table gives the efficiency of steam cut off at various other points of the stroke :

Cutting off at	stroke	increases efficiency	times.
"	" $\frac{1}{10}$	"	3.3
"	" $\frac{1}{8}$	"	3.0
"	" $\frac{3}{10}$	"	2.6
"	" $\frac{1}{4}$	"	2.39
"	" $\frac{2}{10}$	"	2.2
"	" $\frac{3}{8}$	"	1.98
"	" $\frac{3}{10}$	"	1.82
"	" $\frac{1}{2}$	"	1.69
"	" $\frac{6}{10}$	"	1.50
"	" $\frac{5}{8}$	"	1.47
"	" $\frac{7}{10}$	"	1.35
"	" $\frac{3}{4}$	"	1.28

These figures give a general idea of the economy gained by the practice of cutting off the steam at various points of the stroke, but, as is evident, the end of economy is obtained by altering the final pressure in the cylinder, and, consequently, also the mean effective pressure throughout the entire cycle. If, therefore, we wish to utilize the full power of any given boiler pressure, the end of combined economy and high efficiency is far better attained by the operation known as compounding.

Limits of Varying the Valve Motion by the Link.—On the question of the practical limits of varying the cut-off of the valve, by varying the motion on the link, authorities seem to vary in regard to the steam engines used on carriages. Several manufacturers, however, use a notched quadrant for enabling the driver to shift the link, as desired, and with apparently good results, in spite of the oft-repeated claim that the engine of a steam carriage is too small to allow of a very wide variation in this respect. On the authority of one or two practical steam-carriage drivers, whose opinions have appeared in print, it may be stated that some advantage in point of steam economy has been achieved by varying the cut-off from, say, seven-eighths to one-half stroke on a level roadway. The majority opinion has it, however, that, although some saving may be achieved in this direction, proper care and management of the motor and parts attain the end far more effectively: since the strain on the driving mechanism incident to shifting the link

increases wear and tear in an even greater proportion than the gain in steam saving. In short, the situation seems to be that a small steam motor requires a fly wheel to compensate for the jar resulting from frequent shifting of the steam inlet.

On Compounding a Steam Engine.—A compound engine is one in which the steam is used several times over in as many separate cylinders, although usually applied to engines operating with two cylinders. The steam is fed from the boiler direct to the first cylinder, in which it is cut off late in stroke, in order that its pressure may be utilized to the greatest possible extent. The exhaust from this cylinder is then fed into the second cylinder, generally two or three times the cubic contents of the first, and is worked expansively to a point as near atmospheric pressure as possible. The most practical and efficient application of this principle is in the triple and quadruple expansion engines, so largely used in marine work, which, in connection with the vacuum-producing condenser, allows the steam to be worked from the highest available pressure down to practical zero. There are two common forms of compound engines of two or three cylinders, which from the arrangements of the working parts, are known as "tandem-compound" and cross-compound." In the tandem-compound engine, the cylinders are placed end to end, the several pistons operating one piston rod. In the cross-compound engine the cylinders are placed side by side, the two or more piston rods operating on a single crank-shaft. The latter model is that most frequently used in compounding steam engines for motor vehicles.

CHAPTER NINETEEN.

SIMPLE STEAM CARRIAGE ENGINES.

American Steam Carriage Engines.—In the particular construction of steam engines for use on motor road carriages there has been almost as much variety of design as in the other branches we have already noticed. We may say, however, that the typical engine for steam carriages, as constructed in America, is the two-cylinder, double-acting engine, reversible with the Stephenson link motion. The high perfection to which these engines have been brought in America enables the construction

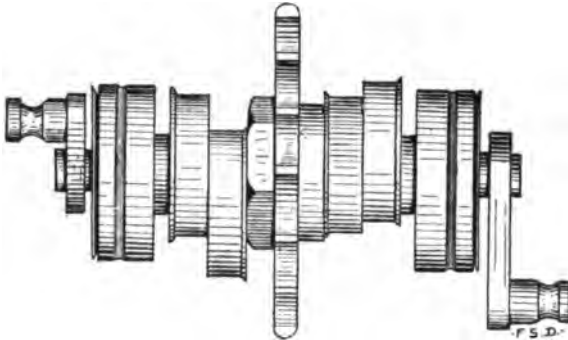

FIG. 245.—Crank Shaft of the "Locomobile" Steam Carriage, showing the cranks at both ends, the ball bearings and eccentrics, and the sprocket at the centre. Most steam carriage engines have similarly arranged crank shafts, although with several makes the entire mechanism is turned from one solid casting.

of very small motors, and the production of a high percentage of power. As a usual thing such engines work simple, but several excellent types of the American steam carriage, such as the McKay and the Stearns, are equipped with compound engines, which, however, may be run simple when the extra power is required, as, for instance, when ascending steep grades, or running through unusually heavy roads. A few steam carriages, notably the Reading carriage, are also equipped with single-acting multiple cylinder engines, which combine peculiarly ingenious devices for effecting reversal and controlling the valve

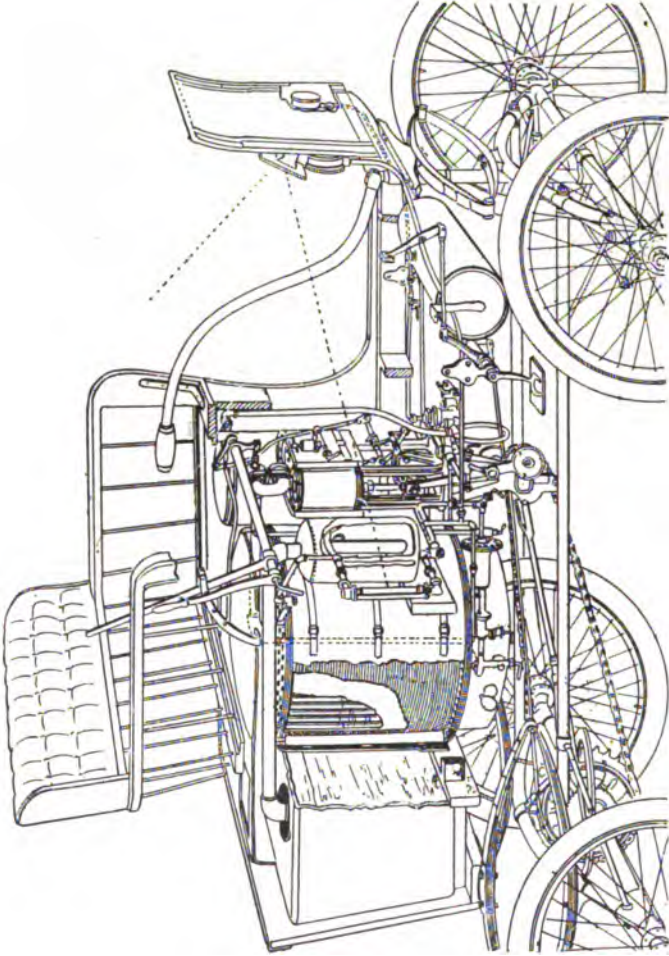
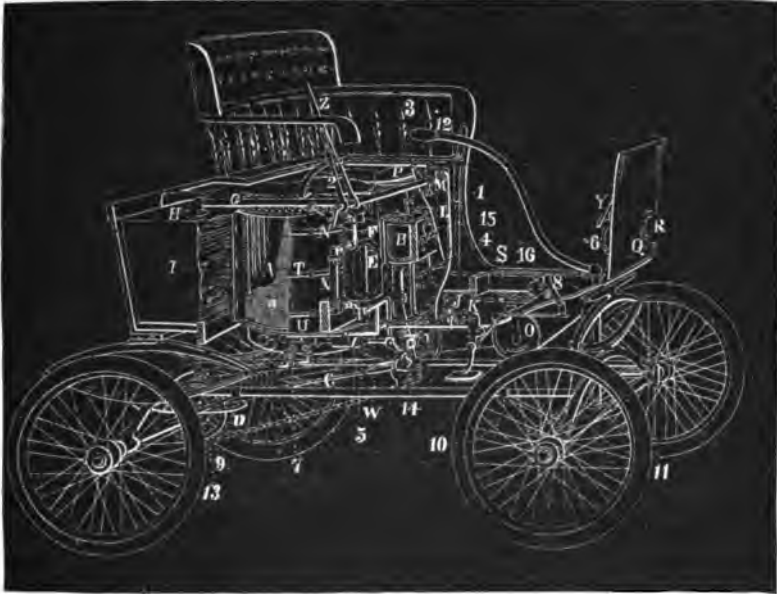

FIG. 244.—Part sectional view of the "Locomobile" Steam Carriage, showing machinery and parts in position.

gear. Single-acting steam engines, with from two to six cylinders, have also been brought to high perfection in Europe, being most familiar in the Gardner-Serpollet carriages.



SCIENTIFIC AMERICAN.

FIG. 245.—Diagram of the "Locomobile" Steam Carriage, showing parts in position. A is the boiler shell of copper; a, the winding of steel piano wire; B, the double cylinder engine; C, the adjustable strut, or distance rod; D, the compensating gear; E, pipe leading from engine to muffler, F, for exhaust steam; G, pipe leading from muffler to vent at H; I, the water supply tank; J, feed pump operated from the engine cross-head; K, cock in front of check valve on water supply pipe, for cutting off the supply from the tank; L, pipe leading from pump to the by-pass, M; N, lever for operating the by-pass; O, fuel supply tank; P, reserve air tank; Q, the dashboard; R, the air-pressure gauge; S, pipe leading from fuel tank to burner, through which gasoline is passed under air pressure; T, metal straps holding the lagging, U, around the boiler; A; V, the diaphragm fuel feed regulator, explained in connection with Fig. 207; W, pipe leading steam from boiler to diaphragm of the regulator; X, the water glass; Y, the mirror for reflecting the water glass; Z, starting lever. Other parts are: The crank arm on Z acting on the lever (1); the reversing lever (2); crank arms on the reversing lever (3 and 4); the pop safety valve set at 240 pounds (5); the steam pressure gauge (6); fuel valve to main burner (7); foot pedal (8) operating band brake (9); wire wheel spokes (10); pneumatic tire (11); steering handle (12); sprocket on rear axle (13); blow-off valve (14); oil feed cup on engine cylinders (15); pipe from air tank to fuel tank (16).

The "Locomobile" Carriage and Its Engine.—One of the most efficient among the American double-acting simple engines is that operating the "Locomobile" steam carriage, which has two cylinders of $2\frac{1}{2}$ inches diameter by 4-inch stroke, and a total

output of 4 to 5 horse-power, at between 300 and 400 revolutions per minute. It is equipped with the Stephenson link motion and "D" slide valves, and operates the boiler pump from the crosshead. The crank shaft of this engine, shown in the

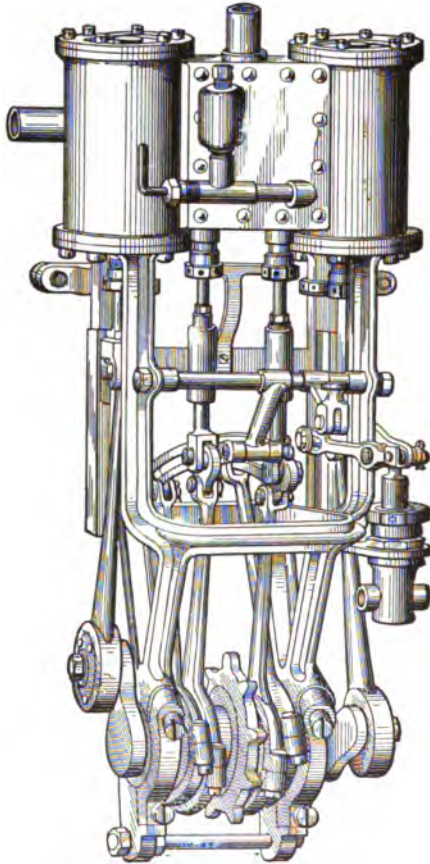

FIG. 246.—The "Locomobile" Steam Carriage Engine.

accompanying drawing, carries the sprocket at the centre, the eccentric drums on either side, and runs in enclosed ball races, with the cranks at either extremity. The cranks are fixed at 90 degrees. As seen from the accompanying figure of the en-

gine, the cylinder and driving gear are hung on a heavy cast frame. This frame is bolted to a wooden crosspiece rigidly attached to the body frame of the carriage.

To the base of the frame is attached an adjustable strut, or distance rod, by which its relative position, as regards the rear axle, may be varied by a right-and-left threaded nut, or turn-buckle. By this device the slack of the chain may be taken up, and, to allow for the slight variation, thus necessitated, the steam pipe connection to the top of the steam chest is by a U-shaped pipe provided with "expansion joints."

The boiler used in this carriage has already been described

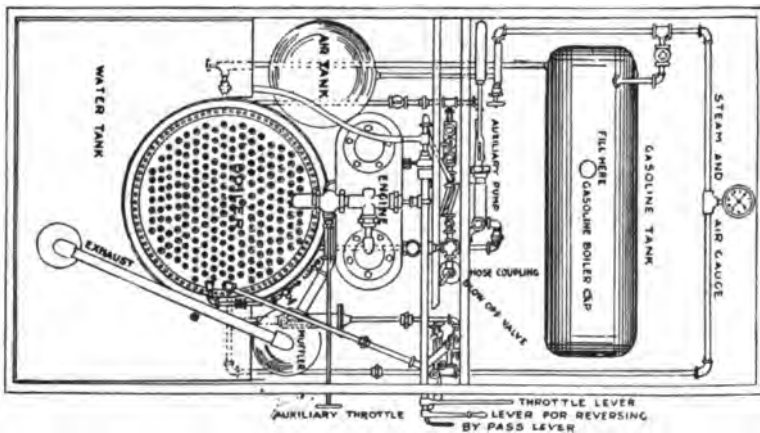

FIG. 247.—Plan Arrangement of the "Locomobile" Steam Carriage, showing position of the parts indicated in Fig. 245.

in connection with Fig. 144. It is supplied by a small plunger pump operated from the crosshead of the engine, drawing its water from the tank shown at the rear and either side of the boiler. On the runabout carriages of this make the water tank has a capacity of fifteen gallons. The water may be cut off by closing the cock, shown at *K* in the lettered diagram of this carriage, or may be returned to the tank by opening the by-pass valve, *M*, by the lever, *N*, at the driver's right hand. Up to the present time the manufacturers of this carriage have avoided the use of most automatic devices, other than the fuel regulator, as already described,

The underframe of the "Locomobile" carriage, described in connection with Fig. 61, is that covered by the Stanley patents, although very similar constructions are used on a number of other carriages, propelled by both steam and gasoline.

The "Toledo" Carriage and Its Engine.—The same general description applies to the simple engines used on several other well-known makes of the American steam carriage, among which should be mentioned the engine of the "Toledo" carriage, which has two high-pressure cylinders, 3-inch diameter by 4-inch



FIG. 248.—"Toledo" Steam Runabout.

stroke. The special feature of this engine is that, instead of the ordinary "D" valves, it is equipped with piston valves, thus insuring better balance, and preventing leakage of steam, which is very apt to result in small engines. The cylinder pistons are each provided with two spring packing rings, thus insuring extra tightness. Among the specially commendable features of this engine may be mentioned the unusually large bearing surface of the crosshead, which, according to the claims of the manufacturers, is 150 per cent. above that demanded by standard formulæ. This large bearing surface insures an unusual immunity

from wear, which, should it occur, may be readily remedied by the use of the specially attached bearings, which may be fixed on, whenever required. The piston rod and cranks are entirely encased, and the end of the crank rod carries an ingeniously arranged scoop, which enables the oil at the bottom of the casing to be thrown on the crank-bearing at every revolution, thus involving the extremely desirable feature of perfect lubrication of the crank-shaft bearings. The engine is reversed by the Stephenson link motion, the cranks, eccentrics and sprockets being of forged steel, hardened and tempered.



FIG. 249.—Engine of the "Toledo" Steam Carriage, showing piston valves, enclosed cranks, and relief cocks on the cylinders.

According to the published claims of the manufacturers, this engine can develop 1 horse-power for each 24 pounds of water consumed per hour. Steam is supplied by the Morgan tubular boiler already described. Like the majority of such carriage engines, it operates the boiler feed pump from its crosshead, the water being pumped through the combined feed water heater and muffler, especially designed for this carriage, and heated to a temperature of 208 degrees before being taken off as steam. The high efficiency of this arrangement may be understood from

the statement that at least 15 per cent. is saved in fuel consumption. The manufacturers assert that the "Toledo" carriage has shown a record, in repeated trials, of 85 miles on 9 gallons of gasoline, and 35 miles on 31 gallons of water, over ordinary country roads. The carriage thus reported weighs in the neighborhood of 1,500 pounds. The excellent construction of the engine, as is claimed, enables instantaneous reversal at full speed with minimum of jar or wear, which should be a great advantage in crowded streets. The "Toledo" carriage is



FIG. 250.—The "Victor" Steam Carriage.

equipped with a steel tubular flexible underframe of excellent design, which has shown high ability to withstand most of the strain of ordinary running. The running gear of the engine is entirely encased and protected from dust and other abrasives. The differential is of the ordinary bevel gear type, the two master gears meshing with five bevel pinions. The gasoline and air tanks used on this carriage are made of cold-drawn seamless copper tubing, and are tested at a pressure of 200 pounds. There are two gasoline tanks which have a capacity of 40 gallons.

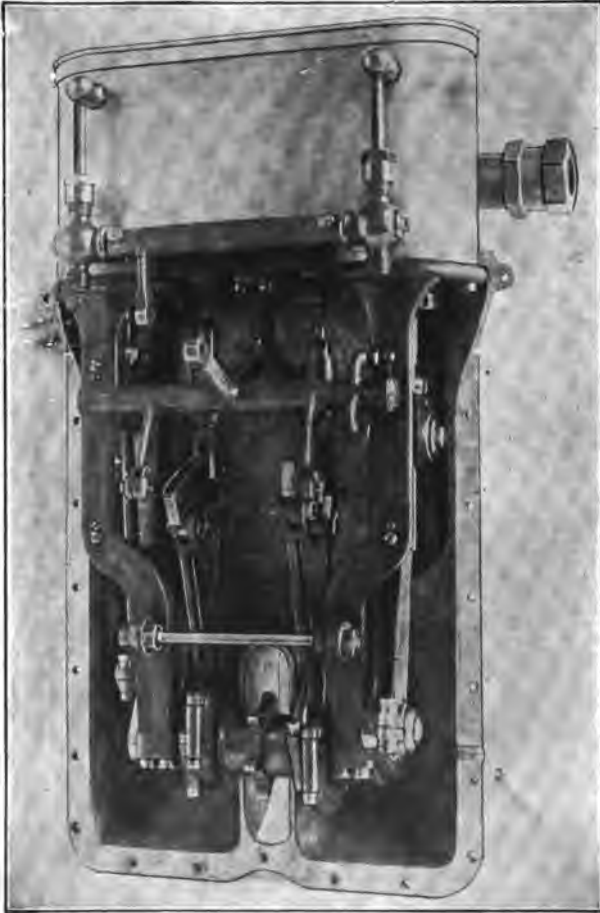

FIG. 251.—Steam Engine of the "Victor" Carriage, showing front of casing removed, also one tube-trunnion for hanging to the body frame.

The "Victor" Carriage and Its Engine.—The engine used on the "Victor" carriage is a two-cylinder reciprocating engine, each cylinder having a $2\frac{1}{8}$ -inch diameter by 3-inch stroke, equipped with piston valves and the Stephenson link motion, and is rated at 4 horse-power. Like the one just described, it is entirely enclosed in asbestos lining and a cover of tinned sheet iron. All the bearings are plain, and the hand and wrist jour-

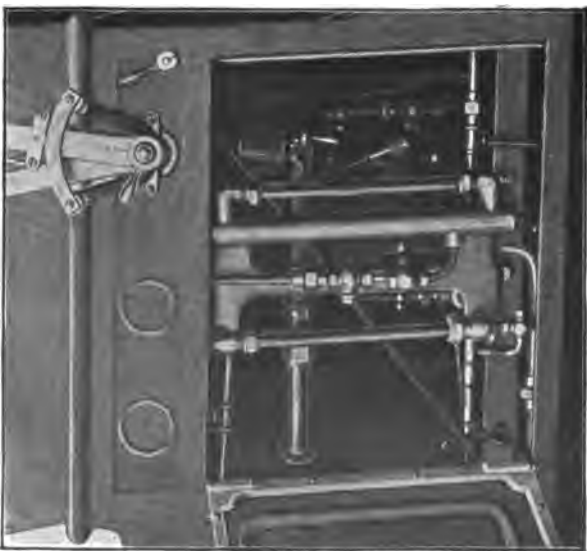

FIG. 292.

FIG. 292.—Left-hand Side of the "Victor" Steam Carriage, showing throttle and control levers, also water glasses and fusible plug seat through open door.

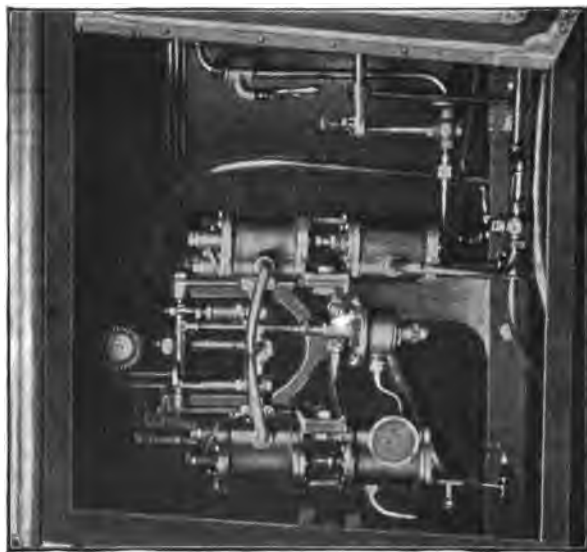

FIG. 293.

FIG. 293.—Right-hand Side of the "Victor" Carriage, showing steam air and water pumps previously described.

nals are provided with hardened and ground steel sleeves running in bronzed bushed castings. Each pair of eccentrics is made from a solid piece of steel, thus preventing all possibility of relative displacement. The quadrant of the reverse lever is so arranged that the point of cut-off may be varied from $\frac{1}{3}$ to $\frac{3}{4}$ stroke, thus involving a corresponding variation of the efficient power to accommodate the carriage on a grade or roughness of road surface. The working parts of the engine are enclosed in an aluminum case, and run in oil. The engine is hung on two hollow trunnions, one being the admission and the other the exhaust pipe. The uniform distance with reference to the rear

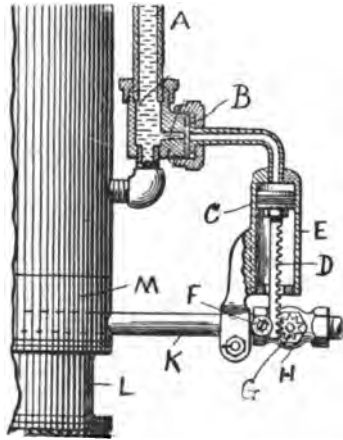

FIG. 254.—Diagram of the Bullard Fuel Cut-off, used on the "Victor" carriage. A is the water level glass; B, the fusible plug; C, the piston to be driven downward by steam when plug is melted; D, rack attached to piston; E, cylinder in which piston slides; F, roller for holding rack in line; G, spur pinion controlling fuel valve; H, fuel valve; K, pipe to burner; L, burner; M, boiler.

axle is maintained by an adjustable distance rod, which may be lengthened or shortened as conditions demand. The adjustment of the chain is regulated by this same rod.

Contrary to the plan usually adopted, the boiler feed pump is not operated from the crosshead, the boiler being supplied by the auxiliary steam water pump with the Westinghouse valve motion already described in the chapter on boiler feeders, and by another pump of the double plunger type, which is geared to and operated from the rear axle. The positions of these pumps with respect to the boiler may be understood from Fig. 253. The

by-pass valve is controlled by the Bullard thermostat regulator, already described, and the supply of gasoline to the burner may be cut off at any time by the fusible plug and piston arrangement, also contrived by Mr. Bullard. As shown in the chapter on boilers, the "Victor" carriage is equipped with a shell and flue boiler of 16 inch diameter, 13 inch height. The steam feed pipe passes up through the boiler from the bottom, taking off the steam about $\frac{3}{8}$ inch from the upper crown sheet, and carrying it down, passes it through the super-heating tube, directly over the burner; from this point it passes directly up inside the boiler lagging, and is connected with the engine at the top. (See Figs. 148-149). This arrangement insures thoroughly dry steam in the cylinders.



FIG. 255.—The "Locke" Flexible Joint Swinging Throttle, used with the "Locke" carriage engine.

Among the other excellent features of this carriage, may be mentioned the spring catch under the cushion of the driver's seat, which can automatically lock the throttle when the driver's weight is removed, thus preventing the carriage from being started through carelessness or mischief, when it is left standing unoccupied. In addition to the several automatic devices already described, the end of safety is further ensured by small electric lamps, capable of being turned on at any time, which can illuminate the water glass at night. The glass is also attached to the water tank in order to show the level of the feed water whenever desired. The exhaust steam from the engine passes to the feed water heater and muffler, being there partially condensed and given off at low pressure. A carriage capable of seating two persons weighs, on an average, 835 pounds.

The "Locke" Steam Carriage Engine.—Several concerns in America have produced, and placed on the market, excellent steam engines, designed expressly for vehicle use. Such engines are particularly designed for such persons as intend building their own steam carriages, or who wish to insert a new engine.

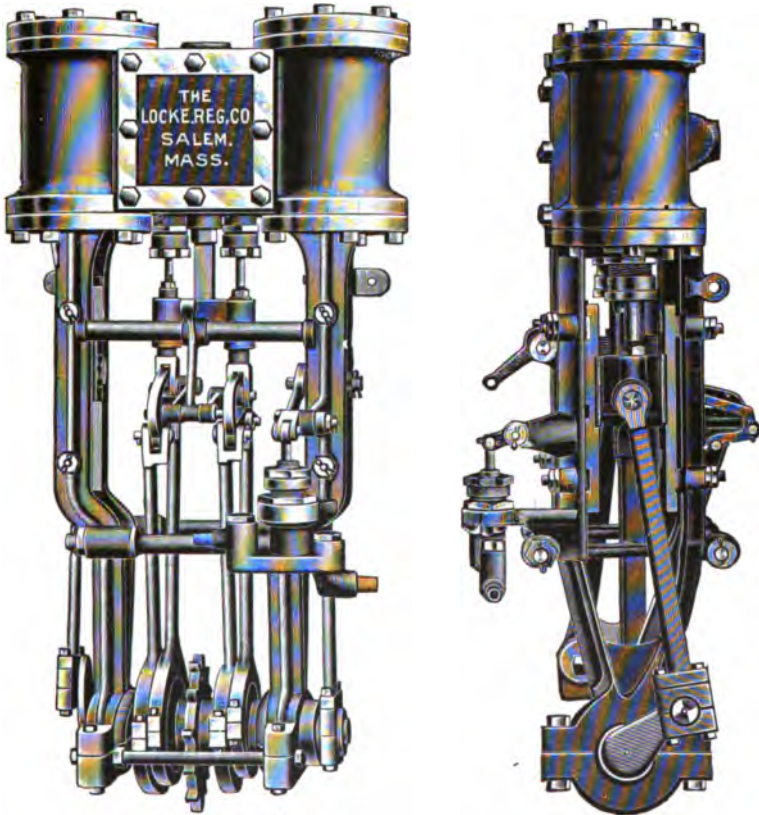

Figs. 256 and 257.—Front and Side Elevation of the "Locke" Steam Carriage Engine.

Several types of such engines are shown in accompanying illustrations.

The "Locke" steam engine is of the usual double-cylinder type, equipped with the Stephenson link motion, and having the boiler feed pump operated from the crosshead. The crosshead

has V-shaped double guides, fixed between the upright pieces of the frame, as shown in the side elevation of the engine. The cylinders, made of grey cast iron, are $2\frac{1}{2}$ inches in diameter by $3\frac{1}{2}$ inch stroke, developing $4\frac{1}{2}$ H. P., at full steam. The frame is made of composition gun metal; the connecting rods being steel drop forgings, and the boxes of bronze. The two main bearings of the crank shaft are made unusually large and heavy; being $1\frac{1}{2}$ inch breadth on each side of the sprocket, where the strain of

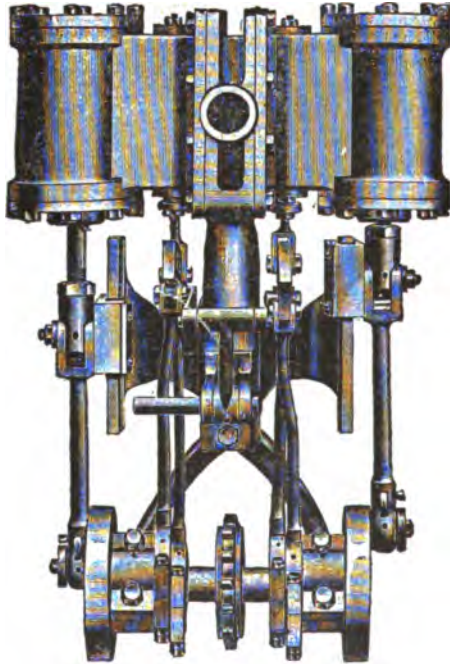

FIG. 258.—The "Eastman" Steam Carriage Engine.

running is most encountered. The valves are set to cut off, so as to vary the expansion of the steam in cylinder. The stuffing-boxes are made with a view to security and ease of repairing; the nuts being held by steel springs, so as not to change their position. The cylinders are heavily jacketed with asbestos lagging. Lubrication is by oil pockets, securing the best effect in a plain bearing engine.

In connection with the equipment of this engine is the flexible swing-joint throttle valve, which is one of the necessary features of a steam carriage equipment. It is so constructed as to allow the engine to swing with the carriage and keep the chain straight. With stiff joints the danger of wear and breakage is greatly increased. The swinging joints are ground and packed, so as to render the connections both flexible and steam tight. The stem and valve discs are made of solid composition metal.

The Eastman Engine.—Another practical engine for steam carriages is the Eastman, shown in an accompanying cut. This engine is manufactured in several different sizes to suit requirements of carriage size, weight and speed, but all have the same general proportions and construction. As may be understood from the cut, one of the foremost advantages to be urged is the combination of simplicity and strength of construction. The frame is rather less complicated than that used on the typical engine. The crossheads work on a single guide, but the operation is balanced by the counterweights on the crank pins. The bearings of the crank shaft are broad in proportion to the length of the shaft, which, as shown, is of unusually large diameter.

CHAPTER TWENTY.

SINGLE-ACTING STEAM CARRIAGE ENGINES.

The Serpollet Single-Acting Engines.—In the effort to simplify, as far as possible, the construction and operation of steam vehicle motors, intended for use on light carriages, several inventors have contrived excellent types of single-acting engines. Among the advantages to be derived from the use of this type of motor, we may mention dispensing with the stuffing-box and several other constructions, which involves constant danger of wear and difficulty of repair. Among the best known single-acting steam engines may be mentioned those designed by Leon Serpollet, and used on the steam carriages manufactured by his firm. As constructed by him, the single-acting steam engine

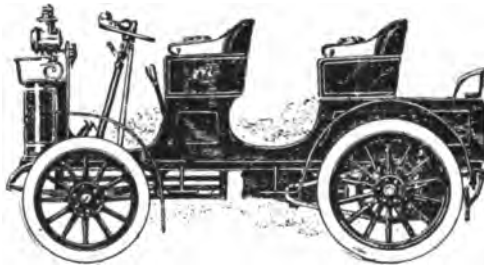

FIG. 259.—Gardner-Serpollet Steam Carriage built for King Edward VII. This carriage fairly represents the designs of Serpollet.

very much resembles some types of gasoline motors used on heavy vehicles, both as regards the cylinder and piston and operation of the valves. In an accompanying figure is shown an elevation, partly in section, of one of his horizontal double opposed cylinder engines. As may be seen there, the cylinders are open at the forward end, toward the crank space, in a manner very similar to that used on gasoline motors of the same pattern. The piston is of the trunk type, consisting of a somewhat elongated hollow cylinder, with the crank rod pivoted on the gudgeon pin somewhat less than midway in its length. The

valves in this engine are of the familiar mushroom or poppet type, and are opened by a push rod positively operated from a cam shaft. This shaft is operated by a spur-wheel, which meshes with another spur of the same diameter, mounted on the crank-shaft, so that the two turn in even rotation. The exhaust valves are of precisely similar construction and are also positively operated from the same cam-shaft.

Such an engine as this has been constructed with from two to six cylinders, and as may be understood, gives about the same

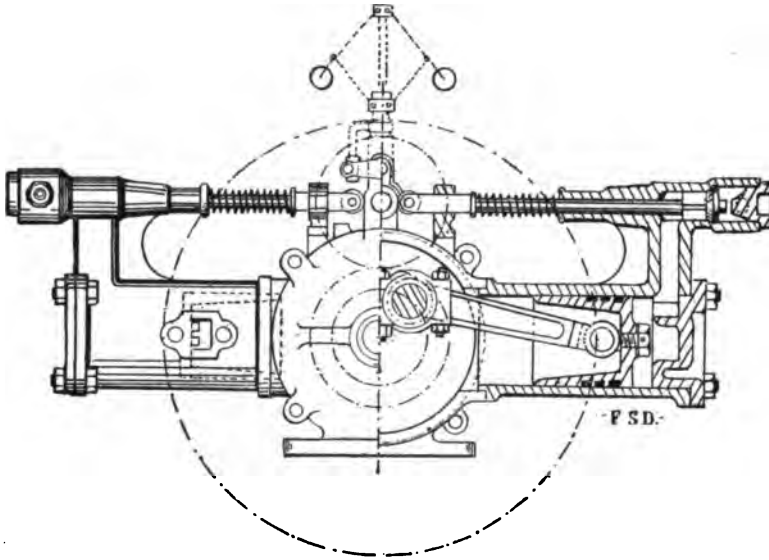

FIG. 260.—One Model of Serralte Single-acting Two-cylinder Engine. As may be seen, this engine, with cam-actuated poppet valves, centrifugal governor for regulating the cam movement, and large fly wheel, closely resembles gas engines of the double-opposed cylinder type.

power effect as an engine of the ordinary design and same proportions of stroke, having from one to three cylinders. The cylinders operate on one plane, and are not offset, as in many opposed-cylinder gasoline motors, the danger of interference of the crank rods being prevented by constructing each of them to embrace only about one-third the circumference of the crank-pin, thus permitting a sufficient play to enable them to adapt their motion to the full dip of the crank. The crank ends of these rods are held in place by clamp brasses at either side. In

a diagonally arranged motor of the same description, the same end of non-interference is attained by forking the crank end of one of the crank-rods, and constructing the other single, so that the former may work over the latter on the crank-pin. As may be understood from the fact that the steam and exhaust valves are positively operated by a series of cams on a shaft, so that when the steam valve of one is open, its exhaust is closed, involving that the steam valve of the opposite cylinder is closed and its exhaust open. In order therefore to reverse the engine,

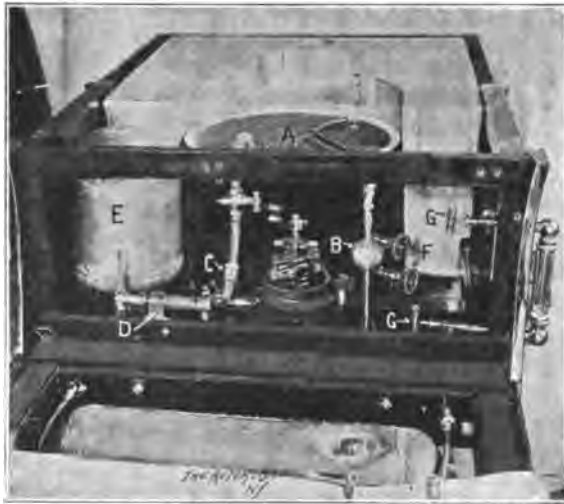

FIG. 261.—The Engine, Boiler and Attachments of the "Reading" Steam Carriage, shown in position. A is the fuel feed tube shown passing down through one of the boiler flues; B, valve for turning off fuel supply from the burner; C, expansion joint between the boiler and engine, permitting of some swinging movements; D, auxiliary hand feed pump; E, try cocks tapped into the boiler shell; G, G, hand valves of the water glass. The fuel tank is shown in the foreground, directly beneath the floor at the driver's feet.

it is necessary only to slide the row of cams on the square cam-shaft that carries them, so as to shift the positions and operation of the valves on the two cylinders.

All the Serpollet carriage engines of this description are supplied by the Serpollet flash generator, already described, the fuel and water being fed and regulated by a system of pumps and valves, already described. For driving an ordinary road carriage, seating two passengers, a two-cylinder motor is used, with a

stroke and diameter each equal to about 2.55 inches, giving, with 700 revolutions a minute and a mean effective pressure of about 75 pounds, an approximate rating of 3 horse-power.

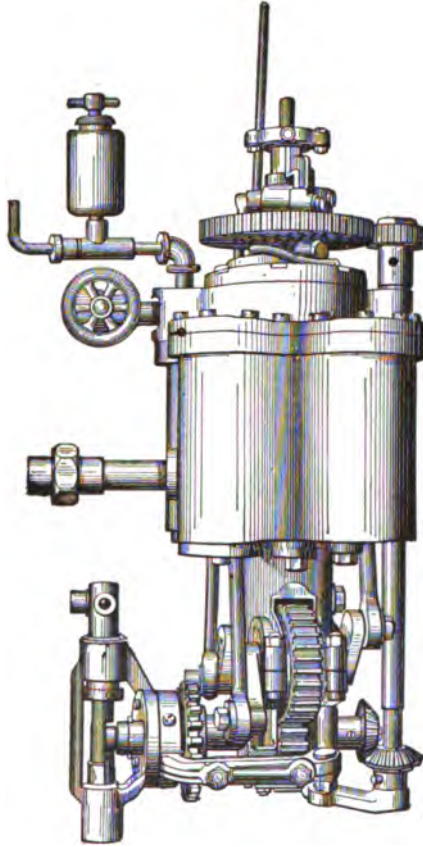

FIG. 202.—Engine of the "Reading" Steam Carriage.

The "Reading" Steam Carriage and its Engine.—The single acting engine used in the "Reading" steam carriage, while having the trunk pistons, as the Serpollet engine, is an eminently more compact and serviceable machine. It consists of four cylinders arranged side by side. As shown in the cut, the steam inlet and exhaust is controlled by a rotary valve at the top.

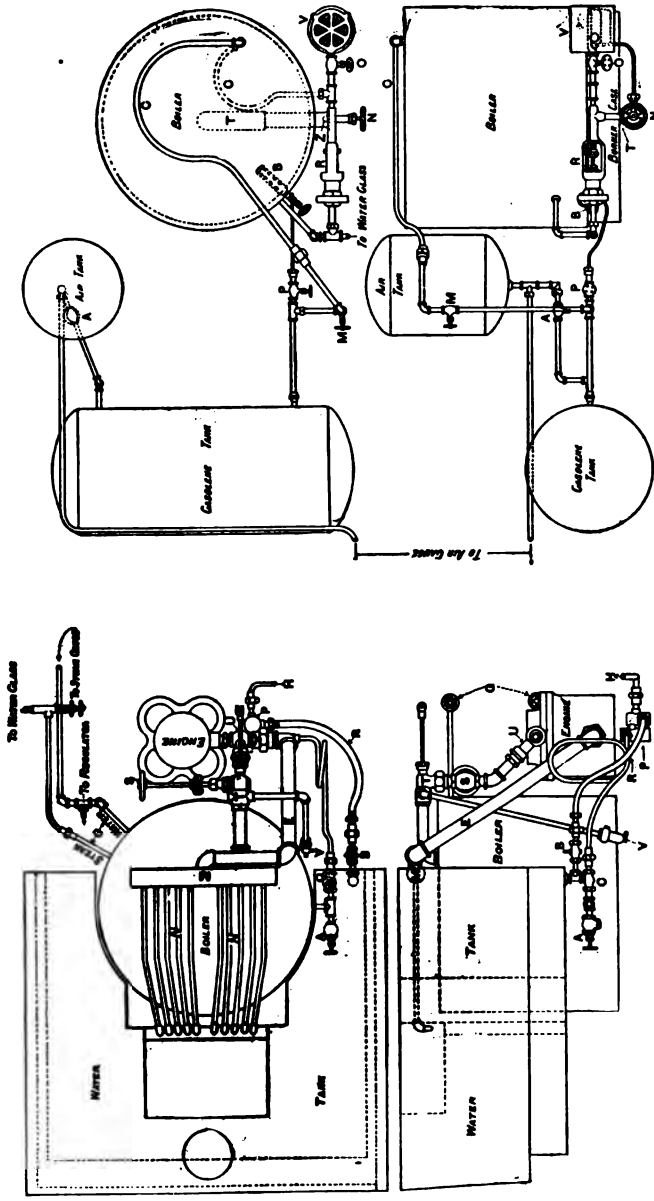

Fig. 263.—Water Feed System of the "Reading" Carriage in Elevation and Plan. A, blow-off cock; B, cock controlling pump suction; C, boiler check valve; E, exhaust pipe; G, steam and water connections to gauge glass, pressure gauge and regulator; H, connection to auxiliary hand pump; M, engine-driven feed pump; N, tank supply to pump; P, engine-driven feed pump; R, tank supply to pump; S, auxiliary throttle to steam pipe, T, operating throttle; U, expansion and swivel joint in steam feed pipe; V, safety valve.

Fig. 264.—Fuel Feed and Control System of the "Reading" Steam Carriage in Plan and Elevation. A, cock between air and petrol tank; B, pilot light; C, vaporizing coils to main burner; M, cock controlling fire (under seat); N, cock controlling main burner; O, cock controlling auxiliary vaporizer; P, main cock to pilot light; R, automatic fire regulator; T, telescopic mixing tube conveying vapor to burner; V, auxiliary vaporizer for starting; Z, main vapor nozzle.

Each of the cylinders has a bore $2\frac{1}{2}$ inches in diameter, and a piston stroke of $3\frac{1}{2}$ inches. The four connecting rods drive four cranks on two crank-shafts; the crank angles of each pair being set at 90 degrees. On each of these two shafts are keyed spur pinions, which mesh with a similar gear on the main shaft, thus maintaining a steady drive.

As shown in the diagram of the valve plan, the piston marked 1 is on the point of beginning its downward stroke; the piston marked 3 just beginning its upward stroke; that marked 2 being

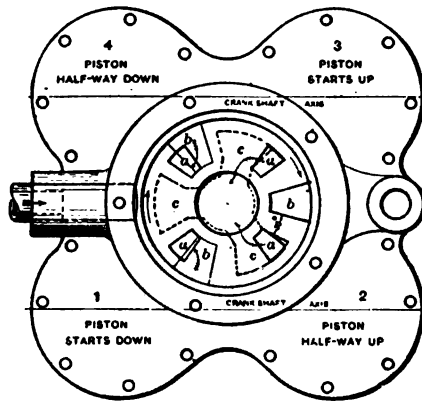

FIG. 265.—Plan of the Rotary Cylinder Valve of the "Reading" Steam Engine. The cylinder ports are shown at *a, a, a, a*; the valve inlet ports at *b, b, b*; the valve exhaust ports at *c, c, c*.

half-way up; that marked 4 being half-way down. Thus, as may be seen, the balance of the motor is constantly maintained. The rotary valve, is kept constantly in motion, supplying steam to the cylinders, by allowing the port, marked *b*, to travel across the ports, marked *a*, the exhaust being accomplished in the same manner, when the ports, marked *c*, open the steam outlet from any one of the ports, *a*. The process of reversing the engine is simple and very readily accomplished. To quote from the published description referring to the accompanying figure of the engine, we have it very simply stated: "It will be seen that if the valve be rotated through the angle *a* plus *b*, or the sum of the steam ports (the crank-shaft not being moved), it will give steam to cylinder 1 at the beginning of a stroke, with the engine run-

ning in the opposite direction, and this is the means used to reverse the engine."

Referring to the lettered diagram, we see that the valve, *Q*, is riveted to the central vertical stem, and the collar *G*, carrying the bell cranks, is keyed to the stem also, so that *G* and *Q* turn together. The gear, *I*, is loose on the stem, but it has two sockets, which receive the lower arms of the bell cranks, *H H*, and it

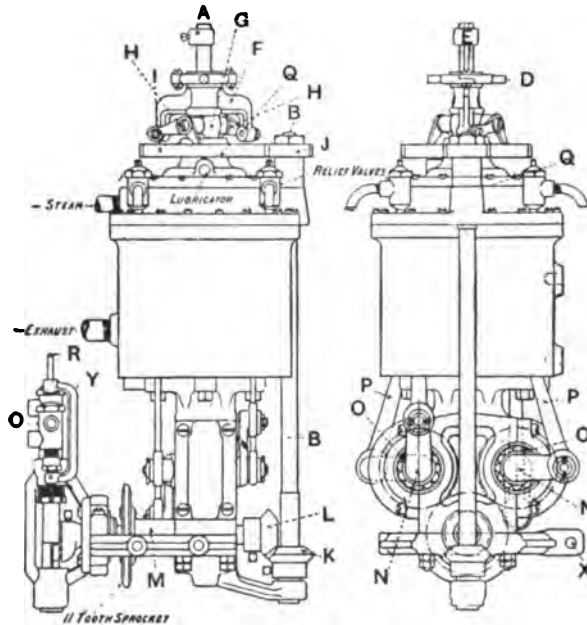

FIG. 266.—Diagram of the "Reading" Steam Carriage Engine. A, rotary valve spindle; B, vertical shaft driving rotary valve; C, suction box of pump; D, split collar of reversing gear; E, stop collar; F, yoke operating bell crank levers for rotating valves and reversing; G, bossed collar carrying bell cranks, H, H, which drive valve, also rotate it to reverse engine; I, spur wheel operating main valve; J, valve pinion; K and L, bevel gears for driving main valve; M, main shaft; N, N, crank shafts; O, O, roller bearings; P, P, P, P, connecting rods of the four cylinders; Q, valve casing; R, feed pump control rod; Y, yoke holding pump; X, stay pivot for chain tightening rod.

drives the valve through the latter. The upper arms of the bell cranks are slotted and are held by the yoke, *F*, which is also loose on the stem. It is evident, therefore, that (supposing gear, *I*, to be standing still) if yoke, *F*, be lowered, collar, *G*, will have to turn a little in a clockwise direction because the lower ends of the bell cranks are boxed, and vice versa. This turns the valve

relatively to the gear, and, therefore, to the crank-shafts, and thus reverses the engine. A collar, *D*, on yoke, *F*, permits the latter to rotate with the valve. The rotation of the valve for forward motion is counter-clockwise. Evidently a valve such as the above cannot be used for a variable cut-off, and nothing of the sort is attempted.

The boiler feed pump is also operated from the main-shaft of the engine, and between it and the piston cranks is keyed the driving sprocket.

The methods of vaporizing the gasoline for the burner, also for starting the burner, have already been described in the proper place. Accompanying figures show the positions of the various parts in the carriage, and exhibit the system of water and gasoline feed employed. The boiler and burner are also of excellent and efficient construction.

There are very few automatic devices in use on this carriage, except the gasoline regulator already described. A hand-pump is supplied, which can compensate for any failure of the automatic pump to supply water to the boiler. The ease of handling the carriage is greatly increased by the use of a single lever for starting and reversing; thus avoiding the complications inevitable at critical moments where two levers are to be used. The throttle-lever can also be used as a brake in case of an emergency. Equally important is the auxiliary throttle, which enables the shutting off of steam from the engine and the removal of the handle, in order to prevent mischievous persons from starting the carriage. The flexible tubular underframe of the "Reading" carriage, described on pages 65-66, is among the best of its kind—the double swivel joints on both front and rear axles permitting the greatest possible distortion on an uneven road, without interfering with the steady drive of the motor. The springs, which are arranged in the width of the carriage, are very long and flexible, both of them being semi-elliptical in shape.

CHAPTER TWENTY-ONE.

COMPOUND STEAM ENGINES.

Compound Steam Engines for Light Carriages.—Although many of the earliest types of the American steam carriage still use simple engines, several of the most excellent of the later patterns have adopted compound engines. The principal objection made by many authorities to the use of compound engines on steam road carriages of light weight is that with cylinders of average dimensions, working power of between 150 and 200 pounds, in the high pressure cylinder, and a cut-off generally between $\frac{1}{2}$ and $\frac{3}{4}$ stroke, which has been found most economical under ordinary conditions, the low pressure cylinder would be doing little or no work, the whole strain of operation coming on the former, which would practically be working against a vacuum. On the other hand, with the final pressure of between 35 and 40 pounds, and the port clearances necessarily amounting to between 20 and 30 per cent., there is a considerable waste of steam, as well as excessive condensation. A well-known manufacturer of steam carriage engines states, that in order to obtain effective work from both cylinders of a compound engine, the high pressure cylinder must be made about one-half the size of the cylinder used in the simple engine. Then, he asserts, the mean pressure will range from 75 to 100 pounds in the usual running, with cut-off at $\frac{3}{4}$ stroke and the diameters of the two cylinders in ratio of 1 to 3, and the low pressure cylinder will do its share of the work, with the desired economy of power. The difficulty claimed with this arrangement is, that the total reserve power will then be only about one-half that of the simple engine, unless boiler steam can be admitted to both cylinders at any desired time while running, as well as in starting, and the back-pressure be eliminated by exhausting from both to atmosphere.

Another objection is that the efficient compound engines used in stationary power plants, on ships, and, to a certain extent in railroad locomotives, are operating constantly against a practically fixed load, which is not the case in steam carriage work.

But this is not of such vital importance, since the average run of compound engines, designed for light road carriage use, may be run simple, whenever it is so desired, and the power may be varied with any well-made simple engine by shifting the point of cut-off. Thus, as is admitted by most experienced steam-carriage drivers, the throttle valve must be very constantly manipulated, in order to maintain anything like uniform speed on ordinary roads, whose surface conditions are ever changing. One important consideration, however, is that a compound engine, with two cylinders of different dimensions, involves considerable vibration, and consequent strain on the parts, such as is not experienced with a simple engine, whose cylinders are uniform as to size and power-output. Thus, when running compound, the small cylinder is exerting a power somewhat in excess of the larger one, and, when both are running with live steam, the larger one is powered two or three times higher than the smaller. Such an objection undoubtedly holds good for a given type of engine, but with the better designed American road carriages, equipped with compound engines, the vibration seems hardly more noticeable than with the easy-moving simple engine.

The Stearns Compound Engine.—The compound engine used on the Stearns steam carriage is one of the most typical and efficient of its class. The high pressure cylinder is $2\frac{1}{2}$ inches in diameter, by $3\frac{1}{2}$ inch stroke, and the low pressure cylinder 3 inches in diameter, by $3\frac{1}{2}$ inch stroke. As is claimed, each develops $2\frac{1}{4}$ horse-power when running compound, and about double that when running simple. As shown in the accompanying diagram, it is built on the usual plan of the double-cylinder steam carriage engine, each cylinder being controlled by piston valves of the usual construction. The valve chest also contains inserts or liners, which increase the accuracy of the parts and admit of ready adjustment when the old liners are worn by use. Between the two valve chests and in connection with both, is the controller valve chamber, which also contains a piston valve, similar to that used in connection with the cylinders, except that it is larger in diameter and has double connections. The position of this control valve may be altered by a lever coming to the hand of the driver, so that at any time the operation of the engine may be shifted from sim-

ple to compound or from compound to simple. This control valve is bored from end to end, and has the usual angular recess on its outer surface, besides the internal port extending clear around the top, bringing into connection various passages leading from the control valve chest to the high and the low pressure valve chests and their exhaust ports. As shown in the illustration, the control valve stands at a point just above the ports which cut off the steam from the steam chests. Were it lowered, so that its top would be even with the bottom port on the high pressure cylinder side, the engine would run com-



FIG. 267.—Compound Engine of the Stearns Steam Carriage .

pound. In this position, therefore, the live steam from the boiler passes from the control valve chest through the port just cleared by the control valve, to the high pressure steam chest, being then distributed by the high pressure valve, as it alternates between the two ends of the cylinder. The high pressure valve being shown in a position where the lower end of the high pressure cylinder exhausts, the path of the steam leaving this end of the cylinder may be easily followed to the steam valve, through the exhaust passage, and the high pressure valve through the passage leading to the control valve chest. Thence, through the

internal port of the control valve, and through another passage leading to the low pressure valve chest, it is distributed alternately to both ends of the low pressure cylinder. As the high pressure piston is shown at one-half stroke, and as the two cranks are

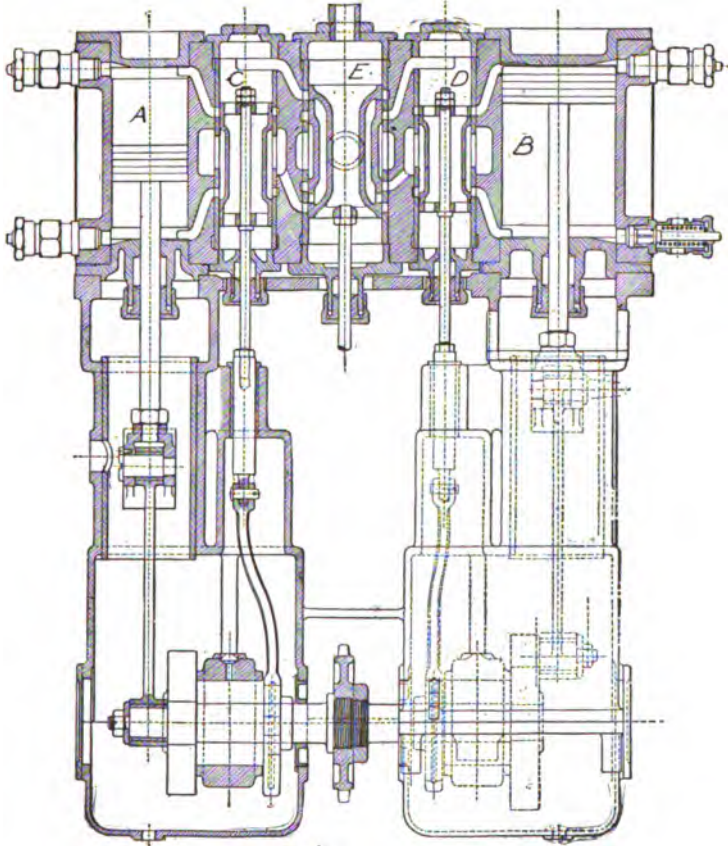

FIG. 268.—Section of the Stearns Compound Steam Carriage Engine. A is the high-pressure cylinder; B, the low-pressure cylinder; C and D, the steam valves operated by single eccentrics; E, the central control valve and chamber.

set at 90 degrees, the low pressure piston is in its extreme inner position, and the lower end of the cylinder is just beginning to exhaust. The steam exhausted from the low pressure cylinder flows through the port to the exhaust chamber surrounding the

low pressure valve, and from there through the passage to the exhaust chamber surrounding the control valve, whence it is led to atmosphere.

If the control valve be raised until the passage shown in the drawing, as connecting the exhaust port of the high pressure cylinder with the internal port of the control valve, be uncovered, the operations of the exhaust and admission ports are reversed and the engine runs in the reverse direction. When the control valve is shifted until it uncovers the passage shown in the drawing, as connecting its internal port with the low pressure valve chest, live steam from the boiler will flow to both valve chests, and the engine will then work simple, thus providing increased power that may be required in an emergency, as when ascending a steep incline or passing over an unusually rough road. Further, by slightly varying the position of the control valve, the steam may also be throttled by this manner of working the engine. The exhaust ports of both high and low pressure cylinders being then in communication with the central exhaust port, both will, therefore, exhaust to atmosphere. As shown in practice, these simple acts of shifting the control valve, may be readily and rapidly acquired, thus enabling the operator to economize both fuel and water by regulating the power output to the requirements of travel. Its practical operation also demonstrates, when running simple, that the average American steam carriage is somewhat over-powered for the requirements of good roads and average speed, and that a large percentage of the steam, ordinarily wasted, may be used for effective work.

The Stearns Steam Carriage.—The Stearns carriages contain several excellent features in addition to this engine, among which may be mentioned a strong and simple underframe, which, dispensing entirely with the usual tubular construction, has the front and rear axle connected with reach rods of hickory wood. This permits of a degree of flexibility impossible with any steel construction, while at the same time dispensing with the complicated swivel joints used on so many other carriages. The capacity of this construction to withstand sudden shocks, and adjust the running gear to the requirements of uneven roadways, amply demonstrates the accuracy of much that has already been said upon the entirely tentative character of tubular framework

in general. While most of these carriages are equipped with the ordinary wire wheels, some models are equipped with the tubular steel wheels, which have been so highly commended by several automobile authorities. As shown in the cut of the engine, both the boiler feed pump and the air pump for supplying the



FIG. 269.—A Stearns Steam Stanhope with Top Raised.

necessary pressure to the gasoline tank, are attached to and operated from the crosshead. The manufacturers have also availed themselves of the advantages involved in the use of automatic appliances, among which may be mentioned the feed water regulator, low water alarm, and fire regulator. The steering device,

which is operated from the side lever, is of exceptionally efficient construction and, in several respects, of new design.

The McKay Carriage and Its Engine.—The compound engine used on the McKay carriage has a high pressure cylinder of $2\frac{1}{4}$ inch diameter and a low pressure cylinder of $3\frac{1}{4}$ inch diameter, and a 4 inch stroke, with a shell and flue boiler 16x16 inches. Five horse-power can be realized under ordinary conditions



FIG. 270.—The McKay Stanhope.

while running compound, but this rating may be increased to 10 or even 12 horse-power, for short distances, by opening the intercepting lever between the cylinders, and admitting live steam from the boiler to both at once. As shown in the accompanying cut, the engine used on this carriage is hung direct upon the boiler and the waterleg. This brings in the excellent feature, not possible with some other arrangements, of steam-jacketing the cylinder by connecting it direct with the steam space of the boiler. Furthermore, when running compound,

the cylinders are connected by a superheater tube, which passes directly over the upper crown plate of the boiler in the shape of a coil. In addition to those excellent devices for insuring economy in the use of fuel and steam the cut-off of the engine may be varied by a lever and notched quadrant, fitted with a locking-

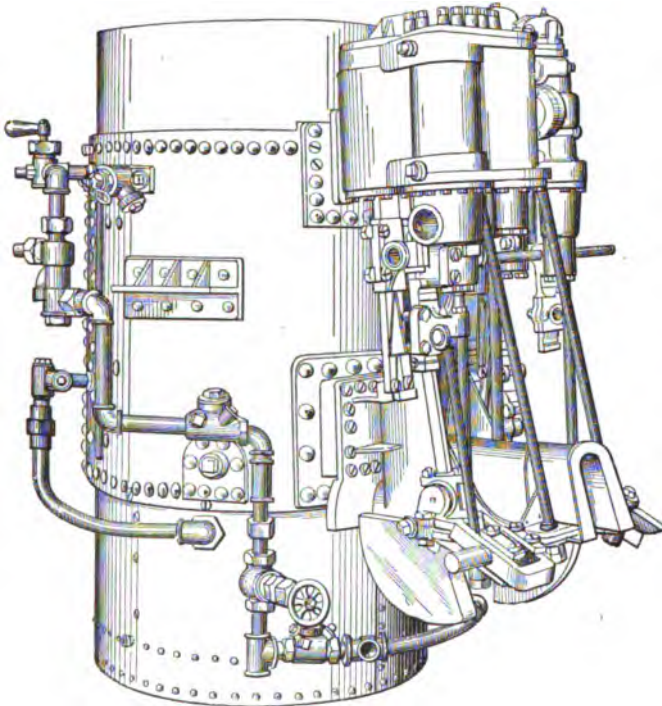

FIG. 271.—Boiler and Burner of the McKay Carriage showing Compound Engine attached. The feed water for this boiler passes through a waterleg around and above the burner, being fed at nearly 200° temperature. The engine may be run either compound or simple, but the two cylinders are connected by a superheater tube passing over the upper tube plate of the boiler, somewhat as in Fig. 149. The advantages of hanging the engine direct to the boiler are the avoidance of flexible connections and in permitting the cylinders to be steam-jacketed direct with live steam.

bolt, which is placed directly at the driver's hand. This lever is also used for reversing the engine. Unlike the majority of American steam carriage engines, this one dispenses with the Stephenson link motion being controlled and reversed by a modification of the Marshall valve gear, so generally used on

marine engines. As embodied in this engine, it enables the reversal by a much simpler method—so the manufacturers claim—than that usually employed; the operation consisting of simply raising the slide shown at the base of the valve rods. The boiler is regularly fed by a plunger pump, operated through a swinging link from the crosshead of the engine. An injector is also attached to the boiler for use in emergencies, or in filling the water tank from a wayside stream. The water then passes through a preheating coil around the burner space, which forms

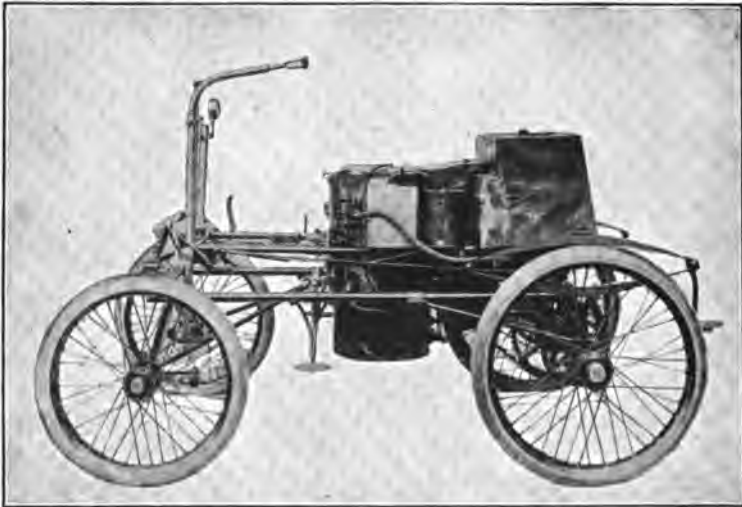

FIG. 272.—Underframe and Running Gear of the McKay Carriage, showing the position of the boiler and water tank. The gasoline tank in this carriage is inside the water tank, being thus entirely surrounded by water and protected from the fire. Contrary to the practice of most other American steam carriages, the engine is placed at the rear of the boiler, hence nearer the drive sprocket. The boiler structure seems longer than in most carriages, owing to the preheating coils, or waterleg, between the top plate of the burner and the base of the boiler.

the waterleg, and is fed to the boiler at a temperature just below the boiling point. The burner used is that already described in a previous chapter under the heading of a "Bunsen Tube Burner." Its operation having been very fully explained, it is only necessary to add that it is used in connection with an exceedingly efficient type of gasoline regulator, which enables the complete shutting off of the fuel supply when the temperature has reached too high a point.



Fig. 273.—Compound Engine of the Thornycroft Steam Wagon.

In another respect the engine of the McKay carriage differs from the usual American practice, in being suspended at the rear of the boiler instead of at the front, as explained in connection with Fig. 272. A further excellent feature is found in the placing of the gasoline tank inside the water tank, thus insuring complete immunity from danger of explosion. The underframe is of tubular construction, but of special design, having a double swivel jointed front axle, which enables the utmost flexibility on uneven roadways. As shown in Fig. 272 also, the boiler, engine tanks and body are mounted on a second tubular frame above the springs. The carriage thus produced is handsome and durable, and as shown by numerous tests, has a speed rating higher than many other American carriages.

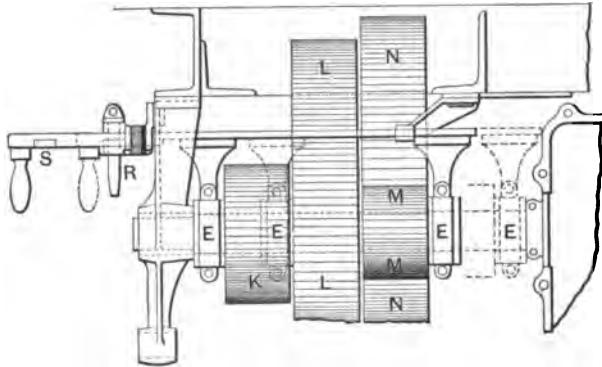

FIG. 274.—Change Speed Gear used on the Thornycroft Steam Wagon.

The Thornycroft Road Wagon and Compound Engine.—The practice of using compound engines on motor road carriages has been much more frequently adopted on heavy wagons and lorries than on light pleasure carriages. One of the best known makes of motor road wagons using compound engines is the Thornycroft, several parts of which have already been described. The engine used on the two and four ton wagons, manufactured under the Thornycroft patents in England and America, is a two-cylinder horizontal compound engine, having a 4 inch diameter for the high pressure cylinder and a 7 inch diameter for the low pressure, and a stroke of 5 inches. The steam valves are of the balanced cylindrical type and are operated by single

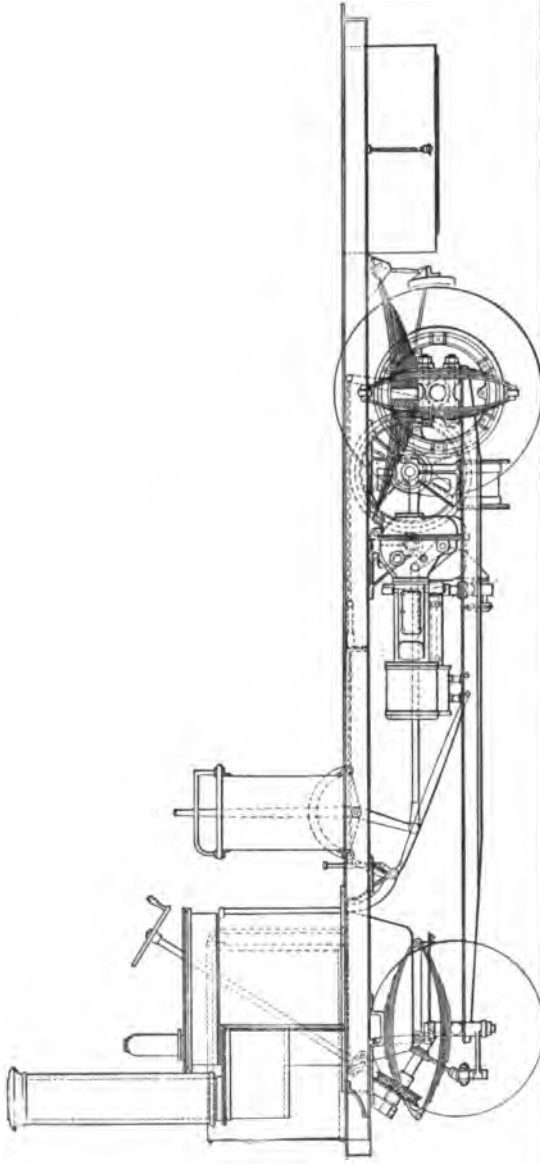

FIG. 276.—Side Elevation of the Thornycroft Steel Wagon, showing engine and parts in position.

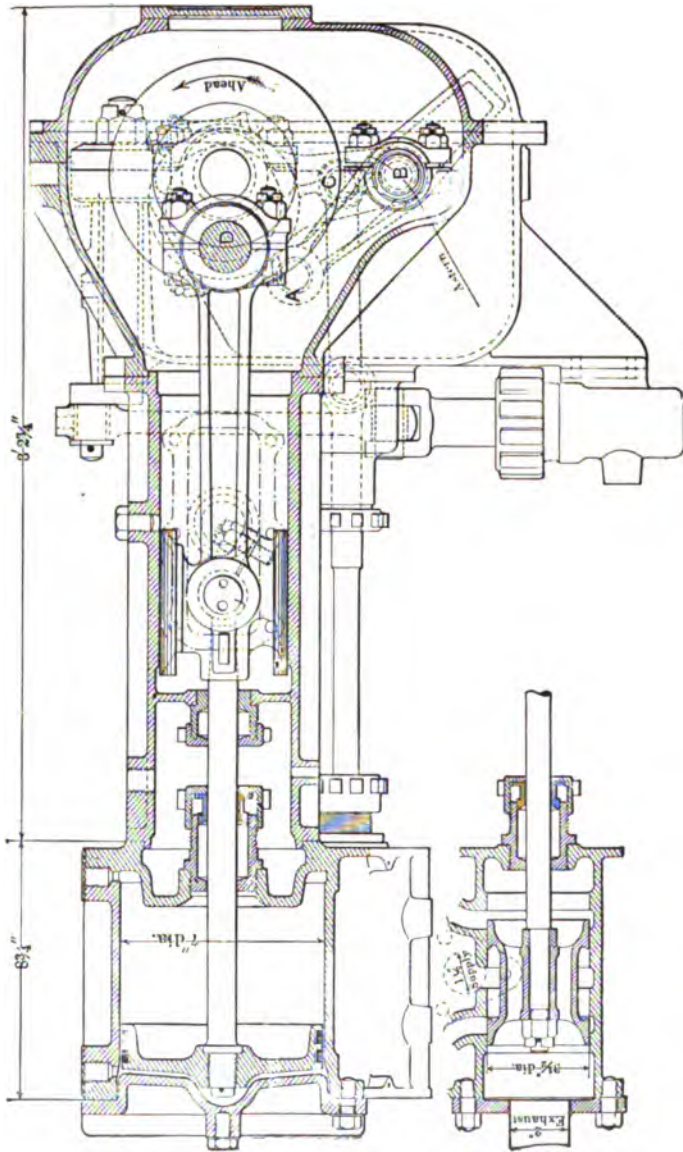

FIG. 276.—Sectional View of the Thornycroft Compound Steam Engine.

eccentric gear from the crank shaft. As shown in the sectional drawing of this engine, the eccentric carries an arm, *C*, which is connected to the valve rod by a link bar. It is also connected to the swinging link, *A B*, by which reversal may be effected. When this swinging link is in the position shown in the drawing, the wagon moves straight ahead; when it is brought downward, to the position marked "astern," the direction is reversed. The intermediate point, of course, has no effect on the movement of the valve. This device furnishes a simple and ready method of controlling the engine, and has the advantage of being less complicated than the ordinary link motion. An engine of the dimensions specified above can develop 20 brake horse-power at 440 revolutions and 35 brake horse-power at 770 revolutions, when the low speed gear is in use. This is an exceptionally high rating for an engine of this size; measuring only $3\frac{1}{2} \times 2\frac{1}{2} \times 1\frac{1}{2}$ feet, and weighing less than 500 pounds.

Contrary to the usual practice with steam road wagons, both light and heavy, the Thornycroft wagon has a system of change speed gears, somewhat on the pattern of those used in connection with gasoline motors. As shown in an accompanying figure, these gears, mounted on a counter-shaft, may be changed by shifting in the width of the wagon by means of a lever, *S*. When this lever is in the position indicated, the low speed gears, *M* and *N*, are meshed. When, however, it is moved to the right, as indicated by the dotted lines, the bearings, *E* and *E*, are also shifted as shown, bringing the gears, *K* and *L*, into engagement. This gives the high speed forward. The operation of the wheels, which are hung on a loose rotating rear axle, as already explained on page 104, in connection with Figs. 89 and 90, affords an exceedingly elastic connection, and great tractive efficiency. The elevation of the wagon, showing the relative arrangement of the parts, is shown in an accompanying figure. The plan is given in Fig. 73 and a description of the water tube boiler on pages 190-193.

The "Lifu" Compound Steam Engine.—The compound steam engine used on the "Lifu" steam wagons is shown in section in an accompanying figure. It is of the cross-compound horizontal type, with reversing links, having cylinders of 3 inch and 6 inch diameters respectively, and a 5 inch stroke. The steam in-

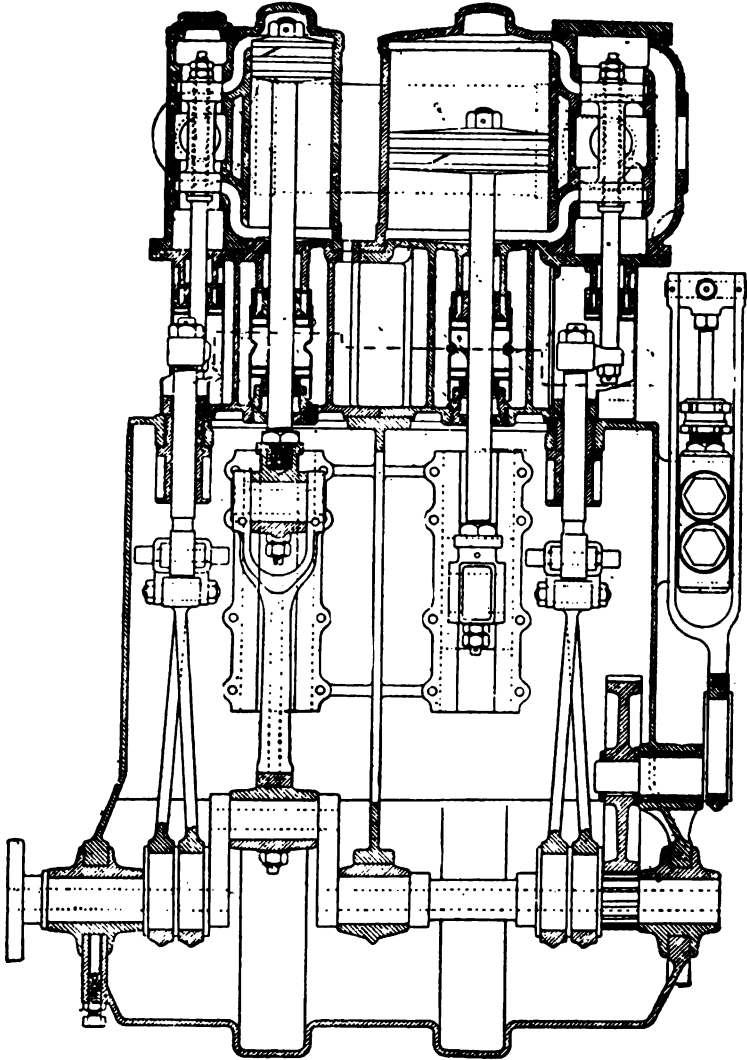

FIG. 277.—The "Lifu" Compound Steam Engine for heavy vehicle use. This section is drawn through the centre of the cylindrical steam chests, which, as in the Thornycroft engine (Fig. 273), are below and at the sides of the steam cylinders. The appearance of eccentricity in the attachment of the piston rods may thus be understood.

let of both cylinders is controlled by simple balanced piston valves, and as indicated in the drawing, the valve boxes are placed somewhat below the general level of the engine. When running compound the steam is exhausted from the high pressure cylinder into a receiver tube, which, as shown by dotted lines in the drawing, connects the two cylinders and their valve boxes from below. There is also an auxiliary valve as shown at the right hand of the low-pressure cylinder, by which live steam from the boiler may be admitted direct to the low-pressure cylinder, thus permitting both to run simple whenever occasion demands, the exhaust from both being then given off to atmosphere.

Among the special features of this engine may be mentioned a second pair of gland boxes run between the forward cylinder head and the guide bars, in order to prevent all leakage of condensed steam into the crank case, which is enclosed so as to allow the moving parts to run in oil. The main feed pump is worked from the crank-shaft, being geared direct to a single eccentric, which works on a small secondary shaft operated from the main shaft by spur-wheels. Attached to the strap of this single eccentric is a forked connecting rod which works on a crosshead attached to the rear of the pump. By this arrangement it is possible to reduce the speed of the pump, since the ratio of the two meshed spur-wheels is about 1 to 6. In addition to this pump, there is also an independent steam pump for use in case of emergency. The steam is generated in a tubular boiler described and illustrated on page 196, which is heated by the House kerosene burner, also mentioned in the chapter on burners.

CHAPTER TWENTY-TWO.

SELF-PROPELLED STEAM FIRE ENGINES.

On Automobile Steam Fire Engines.—One of the most efficient uses of steam engines for driving road and street vehicles, is realized in the self-propelled steam fire engines, which have been used with so great effectiveness in several American cities. The type of engine shown in the accompanying illustration has the following dimensions: A total height of 10 feet, a length of 16 feet 6 inches, a width of 7 feet 3 inches, and a weight of 17,000 pounds, all of which are far in excess of what could be used in the ordinary horse-drawn engine. With these dimensions is achieved a corresponding efficiency for raising water. Up to the successful construction of a self-propelled engine, the maximum of water and pressure possible to be obtained was limited to the weight of an engine, which two or three horses could draw speedily and conveniently through crowded streets, but with the automobile engine these limitations are obviated since there is no reasonable limit of weight that cannot be propelled by its own power. The fire engines of this description used in Boston and New Orleans have repeatedly demonstrated their ability to throw nearly 1,400 gallons of water per minute with tremendous force. At a recent trial of one of these engines, a stream $3\frac{1}{2}$ inches in diameter was ejected through a $1\frac{1}{2}$ inch nozzle to a horizontal distance of 348 feet; through a $1\frac{3}{4}$ inch nozzle, to 338 feet, and through a 2 inch nozzle to $319\frac{1}{2}$ feet. Such an efficiency as this, combined with the possibilities of rapid travel, is sufficient argument for the superiority of the self-propelling fire engine. As repeatedly demonstrated also, such an engine is under perfect control in the street, responding readily to its steering gear, which can turn it completely around in a circle whose radius is equal to its length. Furthermore, by using the reversing lever, it can be stopped in its own length at the greatest speed; can go faster, and also slower, than is possible with an engine drawn by two or three horses, and also takes up less room in the street. The steering is effected by a hand-wheel in front of the driver's seat, which moves the front axle through a system of

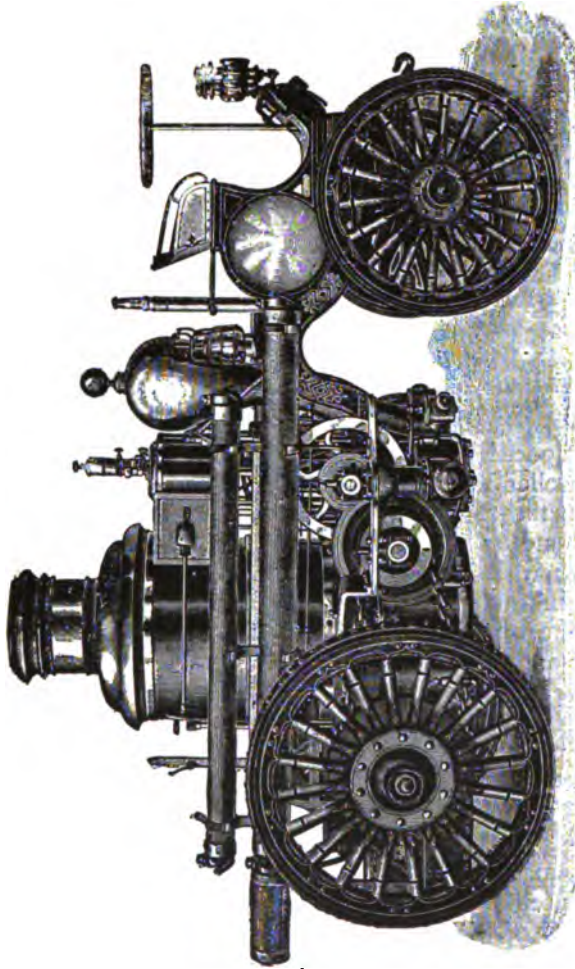

FIG. 278.—An American Self-Propelled Steam Fire Engine.

bevel and worm gearing, so arranged that the steersman is not required to exert his strength constantly to keep the engine in line on the road. The driving power is applied from one end of the main crank-shaft through an equalizing gear and two endless chains running over sprocket wheels on each of the rear wheels, the equalizing gear permitting these wheels to be driven at various speeds when turning corners, in a manner precisely similar to that already explained in connection with motor carriages in general. Furthermore, the driving power is reversible, so that the engine may be driven either forward or backward at will, and by the removal of a key may be disconnected entirely when it is desired to work the pumps.

At the recent extensive grain elevator fire in Boston, one self-propelling engine ejected from three to four tons of water per minute for four consecutive hours, and as a demonstration of the practical efficiency of the work performed, the entire corner of the building, upon which this stream was used, was left standing, while, despite the efforts of one fire boat and fourteen horse engines of modern build and power, all the other sides of the building were levelled to the ground. The force of this great stream was so great that it tore the slate roofing to fragments whenever it struck it, and also forced holes through the sides of the building, through which tons of grain escaped and were saved in a damaged condition.

Briefly, the advantages of self-propelling engines may be summed up as follows:

(1) If a large fire breaks out in any part of the city and a powerful body of water is required at any one point, four lines of three-inch hose may be combined into one stream, of almost any reasonable size of nozzle, giving the benefit of the full amount of water that two of these engines, with a combined capacity of 2,700 gallons, can give. Or, if it is desired, four powerful $1\frac{1}{2}$ -inch streams, at four different points, can be had, thus giving, to a large extent, fire-boat conditions inland.

(2) If another fire, large or small, should break out at the same time, one of these engines could be instantly dispatched, and arrive at the second fire in the quickest possible manner now known. On its arrival, it could instantly use six $\frac{3}{8}$ -inch streams; five 1-inch streams; four $1\frac{1}{4}$ -inch streams; three $1\frac{1}{2}$ -inch streams; two $1\frac{3}{8}$ -inch streams, or two $1\frac{1}{2}$ -inch streams; or

one 1½ or one 2-inch stream, or a 2½-inch stream for a water tower, and from the above mentioned number and sizes produce the greatest effect.

One of these propellers can throw the greatest amount of water upon any building, in any part of the city, quicker than by any other known method; going through snow or mud, or up any hill any vehicle can go, and thus affording the most complete protection that has ever yet been attained.

(3) Self-propelling engines may be handled more quickly than others. The following experiment was made with Boston's engine, No. 38. This engine is located in a double engine house; the other engine having a three-horse hitch. The men were all placed in an adjoining room and the alarm struck, but although the horses made a quick jump, the propeller was out of the house before the harness had been snapped upon them.

To start from the house, but four movements are necessary, three detachments at the rear of the engine and turning the throttle.

The engine should carry in the engine house at all times about eighty pounds of steam, and will run for one and one-half hours without stopping for water.

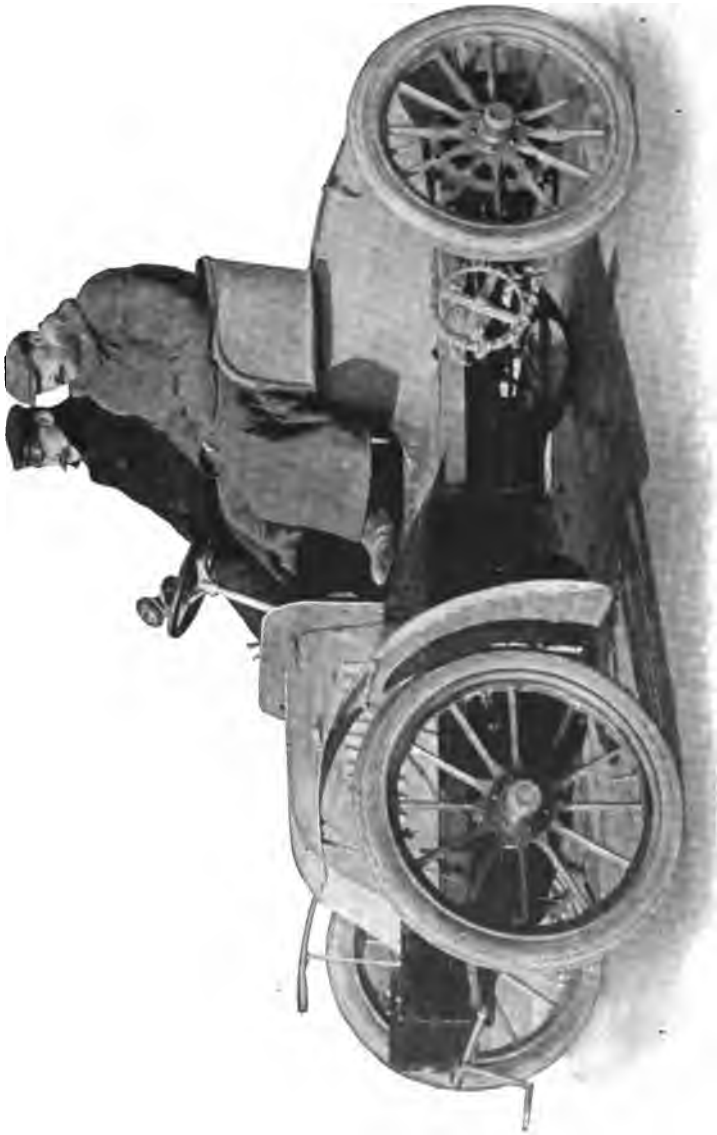

A Typical Gasoline Motor Carriage. The Charron Carriage, one of the latest French makes of automobile, following closely on the designs of Panhard-Levaasor.

CHAPTER TWENTY-THREE.

GENERAL PRINCIPLES OF GAS ENGINE OPERATION.

Advantages of Internal Combustion Motors.—It has been frequently said that steam is the best available motive power found under ordinary conditions for utilizing the vast expansive energy of heat. At a certain temperature water assumes the gaseous state, and its power of expansion is so immense that, when properly confined, it will displace any movable obstacle in its effort to assume greater proportions; thus furnishing the force for driving machinery. Vaporized water, however, is not the only gas possessing such properties. In certain aspects, it is also not the most convenient medium for transforming heat into motive energy, particularly for small power motors. This is true because the steam engine, as we have seen, requires a boiler or generator to produce the steam and a constant source of heat to accomplish this effect. The consequence is that a large percentage of the heat units employed is actually wasted, even in the best-designed engines. This result is inevitable, because the fuel for combustion, the fluid to be vaporized by heat, and the engine to be driven by the expansive energy are all separate and distinct elements, requiring, frequently, elaborate devices to secure the end of co-operation as a practical working unity. If, now, the expansive energy can be derived direct from the fuel and the ignition effected by an intermittent source of heat, it is obvious that the machine is simplified and the total economy increased. In other words, when some such rapidly-acting expansive force, as is found in the explosion of gunpowder, can be so controlled and utilized as to drive a piston, as a gun throws forth its projectile, or bullet, we have achieved the end of transforming heat into power with the smallest possible waste. In the steam engine one large percentage of heat is wasted in raising the water to the boiling point; another, in maintaining the degree of temperature necessary to continual generation of steam; a third, by being absorbed in the cylinders as a necessary means for preventing a checking of expansion. Furthermore, the chimney draught, requisite to combustion in

the heater and as an escape for burned products, acts as a waste in expelling considerable heat through the flue. The nearest approach to the ideal of economy in the steam engine is found in the "flash boiler," as devised by Leon Serpollet, and others, wherein water injected into narrow tubes, already raised to a high temperature by contact with fire, is instantaneously, or explosively, transformed into expansile vapor, to be fed to cylinders, also at a high initial temperature. Even this system involves considerable waste, from the necessity of maintaining the "flash tubes" at the required temperature, between the periods of injection; the wear and corrosion on the metal parts is also excessive. On the whole, its disadvantages are numerous, and render it a very poor substitute for an internal combustion motor, like the modern gas engine.

The Requirements in Explosive Motors.—The internal combustion or explosive engine possesses most of the desirable features, which the steam engine lacks, and realizes many of the requirements of an ideal motor. Its fuel, a hydrocarbon gas or liquid, is properly mixed with air, fed direct to the cylinders, and ignited explosively, so as to be raised instantly to its highest temperature point, by an intermittent source of heat, all in the same small chamber. It is, therefore, merely a cylinder and driving gear, without boiler or furnace attachments; and, on this account, affords a high power efficiency, in proportion to its total size and weight. For use in motor carriages, internal combustion motors must be provided with some device for producing the explosive gas from a suitable liquid; since it is both inconvenient and impracticable to carry it stored in tanks or bottles, which must be constantly charged under high pressure. Such a liquid, moreover, must be one that is readily mixed with atmospheric air, passed through it, or over it, in a specially designed vessel, commonly called a carburetter, or vaporizer, so as to form a true gas with inflammable properties. Several hydrocarbons, such as benzine, gasoline, and some forms of alcohol, are suitable, although gasoline has been most generally adopted for this purpose.

Operation of an Explosive Motor.—The cylinder of a gasoline motor is, as in most gas engines, open at the end toward the

crank shaft. Admission for the fuel gas at the opposite end, which is normally closed, is had by mushroom valves operated usually by suction of the descending piston. The piston is, therefore, single-acting, or moved by an impulse from one direction

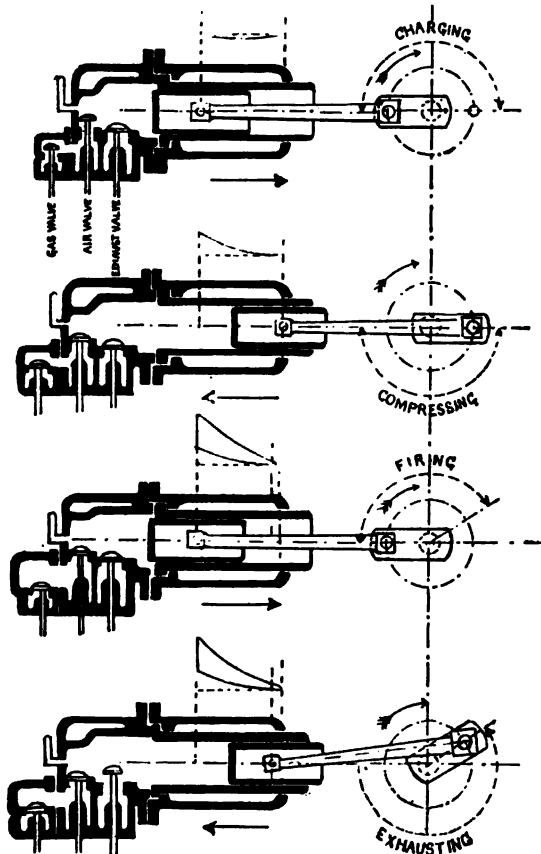

FIG. 279.—The Cycle of an Otto, or Four-Part Cycle, Gas Engine.

only, and is of the "trunk" pattern, having the swinging connecting rod pivoted within. The action of the piston and driving gear is, thus, entirely positive and automatic, in the sense that there is no pressure whatever outside of the cylinder—as in the

steam engine—to effect movements of the parts, when proper valves are opened. An automobile motor is started by turning a crank on the driving shaft a sufficient number of times to carry the gears, cams and valves through the charging, compression strokes, to the moment of ignition, when it will “take up its cycle,” and run by the power generated in itself. The cylinder is charged by an out stroke of the piston, creating a vacuum behind it and drawing in the mixture of air and gasoline gas formed in the carburetter. With some carburetters this is too “rich” to burn readily, so a quantity of pure air is also drawn in. With better carburetters the mixture needs no more air. The charge is then compressed by the return stroke of the piston, which act secures complete carburization of the contained air, and reduces it to the proper degree of mixture to be kindled by the igniting spark or other source of firing. This causes it to explode, or to expand suddenly and with great effect, and drive the piston outward again. The fourth stroke, which is the one immediately following the explosion, is known as the “scavenging” stroke, from the fact that the piston, moving back again in the cylinder, expels the products of combustion through exhaust valves which are operated by cams. This process completed, the parts are in position for a repetition of the process; the valves for admitting gasoline gas to the cylinder then being opened again.

The Cycle of a Gas Engine.—These four strokes—two outward and two inward—are called a “cycle,” and, as may be readily understood, there is thus only one power impulse for every two revolutions of the fly-wheel. This power stroke also continues while the crank is traveling through half a revolution, or through an arc of 180 degrees. It is also evident that the cam shaft, for operating the valve system of the cylinder, revolves but once for every two revolutions of the crank shaft, with which it is geared. Thus is secured the opening of the charging, or “inhaust,” valve, and of the scavenging, or exhaust, at precisely the proper points in the cycle. The operation of a four-cycle gas engine may be understood from this figure: Supposing we have a four-cylinder motor, the cranks of whose four pistons are so fixed that, counting from 1 to 4, we have pistons, cams and valves in positions representing the four cycles. That is to say,

the first cylinder would be performing the inhaust stroke; the second, the compression; the third, the explosion; the fourth, the scavenging. In such an engine the crank would be turned by a steady impulse, since in some one of the four the explosion would be due in every 90 degrees of its rotation. Also every one of the four cycles would be taking place contemporaneously. Thus, may be understood the process essential to the operation of a gas engine of the "Otto," or "Beau de Rochas" four-cycle type.

Two-Cycle Engines.—Practically all carriage motors are built for the four-cycle system, which requires two complete revolutions of the fly-wheel to perform the four necessary acts involved in the use of gas as a motive power. There is, however, a method

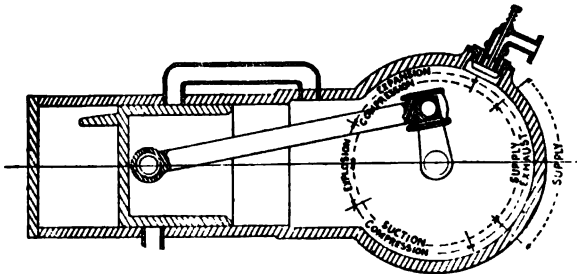

FIG. 280.—Diagram of the stages of a Two-Part Cycle Gas Engine. The out-stroke is from left to right; the in-stroke from right to left. The inner circle around the crank case in front of the piston. The outer circle shows the stages of explosion, expansion, exhaust and compression, which take place behind the piston in the combustion space of the cylinder.

of accomplishing the same results in one revolution, and it is, accordingly, known as the two-cycle system. It uses one rotation and two strokes, the functions of the two omitted strokes being provided for by certain peculiarities of construction. Its essential features are as follows: (1) An enclosed crank case, such as is also used on most vehicle motors, is fitted with a valve geared to open and admit fuel gas at the front, instead of at the rear of the piston, on the first inward stroke of the piston. (2) The inhaust and exhaust ports of the cylinder are located at points about midway in its length, so as to be uncovered by the piston in its downward stroke. The exhaust being reached first, the

products of combustion start to leave the cylinder, partly through their tendency to expand, before the fresh supply begins entering from the enclosed crank case. (3) At the end of the piston, and so placed as to come opposite the entry port for the fresh charge, when it is opened, is a longitudinal plate or screen, which deflects the new gas to the top of the cylinder chamber, thus causing it to assist in the work of expelling the burned products. This work is further completed as the piston starts on its return stroke.

The four acts, admission, compression, ignition and scavenging, are thus accomplished during one revolution of the fly-wheel by the use of two chambers. The fuel gas is admitted to the closed crank case during the inward stroke of the piston, at the completion of which the supply valve is closed. On the return, or outward, stroke this gas is suitably compressed to about five pounds to the square inch, which pressure causes it to rush into the cylinder the moment the supply port is opened. When both the supply port and exhaust port have been closed by the inward stroke of the piston, the contained fuel gas is still further compressed, and is ready for ignition, as the piston reaches the end of the cylinder. The next outward stroke is under power impulse, as indeed is every outward stroke on the two-cycle arrangement; each inward stroke accomplishing the results of supply and cylinder compression, and each outward stroke, the results of ignition, exhaust and recharging.

Two-Cycle Motors for Vehicle Use.—While it would seem from the theory of the two-cycle motor that it should be capable of a higher degree of power as well as a greater speed—features which should render it the ideal motor for vehicles—it is, nevertheless, true that its practical performance is otherwise. It is a very satisfactory type of engine for low speed purposes, and in such conditions will develop, as some claim, a power fully 50 or 60 per cent. greater than with a four-cycle engine of the same dimensions. This statement is questioned by other authorities, but, as may be readily understood, an engine giving a power impulse stroke in every revolution should, theoretically, have twice the available power capacity of one having a power stroke in every two revolutions only. This would undoubtedly give about the practical percentage of superiority named above. At high speeds, such as are contemplated in the construction of

motor carriages, the trouble with the two-cycle motor is that, all the functions of inhaust, compression, ignition and exhaust being performed in a single stroke of the piston, sufficient time is not allowed for the expulsion of the burned gases, with the result that the cylinder "chokes itself up," as the saying is, and its contents fall below the explodable point, stopping the engine. It is thus estimated that, while a four-cycle engine of a given horse-power will run at as high a speed as 1,200 or 1,500 revolutions per minute, a two-cycle engine of the same power can make no more than 300 or 350 revolutions. The same

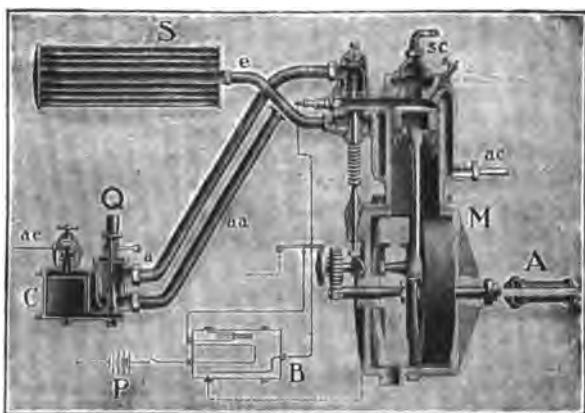

FIG. 281.—Diagram showing the Essential Features of a Typical Carriage Motor, as used on the De Dion Vehicles. M is the motor; C, the carburetter; S, the muffer; P, the sparking battery; B, the induction coil and condenser; Q, the pipe admitting pure air into muffer; aa, pipe for bringing hot air from around exhaust pipe; e, exhaust into muffer; a, pipe admitting gas to cylinder; ac, gasoline feed to carburetter; ac, port for admitting water to the jacket space of the cylinder; sc, exit port from the water jacket.

defect in operation prevents the two-cycle motor from attaining the power efficiency, otherwise seemingly involved in its constructional theory. It is on these accounts that the two-cycle type of motor has thus far proved unavailable for automobile purposes, where the four-cycle engine has proved eminently effective.

The Essentials of a Vehicle Motor.—Every gasoline vehicle must carry its supply of fuel spirit in a tank or receptacle with suitable outlet valves, through which it may be drawn as

required. The motor proper consists of three parts; the carburetter, or vaporizer, in which the liquid hydro-carbon is transformed into vapor; the cylinder, to which it is admitted by suction, mixed with a suitable supply of pure air, compressed and ignited, and an ignition apparatus for producing the spark or hot surface essential to explosion. So far as the operation of the cylinder is concerned there are two general types of engine:

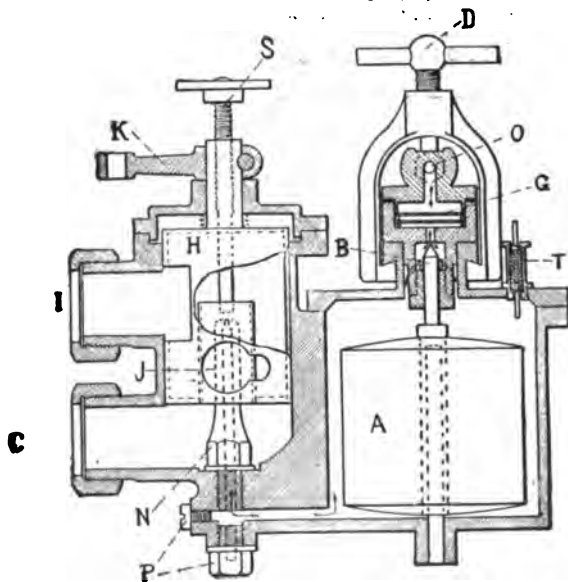

FIG. 282.—Section through a typical Float-Feed Carburetter. This particular device is the one shown in the previous cut. Here A is the hollow cylindrical float; B, the spindle of the needle valve; C, tube for admitting hot air around base of spraying nozzle; D, adjusting screw for the needle valve; H, adjustable air valve; I, outlet for fuel mixture to cylinder; J, adjustable opening for air; K, arm for attaching throttling lever; N, spraying nozzle; O, P, screw caps on channel from float chamber; S, adjusting screw for regulating gasoline spray; T, air vent; G, filtering gauze.

scavenging engines, in which all the burned-out gases are expelled from the cylinder, and non-scavenging engines, so constructed and operated that a certain portion of these residua are retained in the clearance.

There are two general types of carburetter: surface carburetters that operate by evaporation, and float-feed carburetters, or sprayers. A third variety of carburetting device is recognized by some authorities in the type of gasoline outlet valves, such as

the James-Lunkenheimer, or the Winton, in which the gasoline outlet is opened with the air valve, permitting a quantity of gasoline to pass in proportion to the time of opening. This is mixed with the air passing through.

There are several methods used for igniting the charge in a gas engine cylinder. Among them may be mentioned the gas jet and hot tube of the Otto engines; the hot head of the Hornsby-Akroyd and the hot wall of the Diesel motor. Although vehicle engines of the Daimler type still retain the hot tube ignition, most of them operate with an electric spark. Electric sparking devices are of three general types:

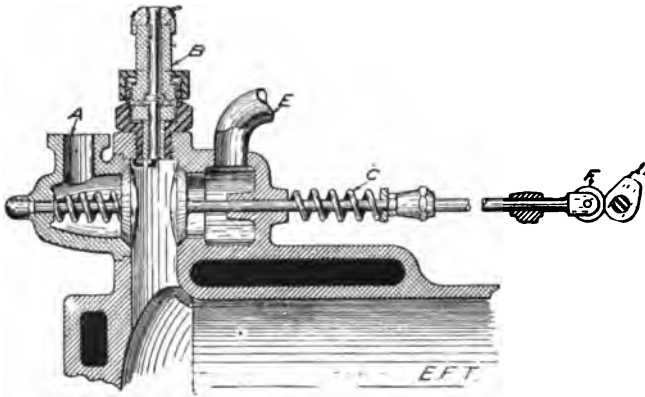

FIG. 283.—Detail Diagram of the Valves and Attachments of a Gas Engine Cylinder. A is the inlet port behind inlet valve held in its seat by a tension spring; B, the spark plug for "jump-spark" ignition; C, the push rod and compression spring of the exhaust valve; D, the cam opening the exhaust; E, the exhaust port; F, the roller at end of valve rod bearing on the cam, D.

jump sparks, wiping sparks and break-contact sparks. The first variety is usually produced from a high-tension current—one emerging from the secondary circuit of an induction coil, the primary circuit being made and broken at timed intervals so as to produce a spark between two points in the secondary, as the circuit is thus broken. The two latter varieties of spark are usually produced direct from the primary current. Many authorities consider the break-contact spark as a variation of the ordinary wipe spark, in which the contact has been so reduced as to escape the great wear occasioned by constant rubbing of metal surfaces. The electric cur-

rent for ignition purposes may be generated by ordinary chemical cells, or by a magneto-generator or small dynamo.

The cylinder is supplied and exhausted by ports closed by poppet or mushroom valves, held in position by springs. The exhaust valve is positively operated by cams geared to the main shaft; the feed valve is generally operated by suction of the piston, although some motors have it also positively geared. Another important function in a gas engine is that of cooling the cylinder; for, unlike the steam cylinder, which is often steam-jacketed and otherwise protected to prevent falling temperature from checking expansion, the gas engine cylin-

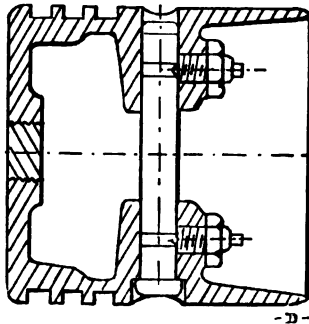

FIG. 284.—Section through a typical Trunk Piston for a Gasoline Engine. Around the circumference, near the rear end, are three circular grooves for inserting the packing rings. Through the central diameter is a perforation for admitting the piston pin, which is held in place by square-headed screws.

The proportions of the piston pin must be carefully calculated for the load it is intended to bear. In general, the length of the piston pin should be equal to that of the crank pin, and its diameter such as to bear an average of 750 pounds for each square inch of its projected area. As given by Roberts, the proper diameter of the pin may be determined as follows:

$$\text{Diameter} = \frac{\text{Cylinder area} \times \text{M. E. P.}}{750 \times \text{length of pin.}}$$

der must be regularly cooled, so as to be maintained at a temperature sufficiently low to prevent premature ignition of the charge and consequent disarrangement of the cycle. It is also necessary to avoid such high degrees as would cause carbonization of the lubricating oil, although oils are produced that will give a fire test of over 600°, a point sufficiently high for most well designed motors. With inferior grades of lubricating oil, and insufficient cylinder-cooling devices, the danger of the engine "grinding itself to pieces" is generally to be feared. This is one excellent reason, as stated by several authorities, why an

air-cooled cylinder is insufficient for vehicle motors of more than two horse-power. It does not cool rapidly enough. There are two methods of cylinder-cooling: air-cooling by transverse, or longitudinal ribbing, by radiating pins or by rotary fan; and water cooling, by circulation of water or other liquid through jacket spaces around the cylinder chamber.

The operation of the engine, as regards both speed and power, is controlled in two ways: by a centrifugal governor on the main shaft, or by a throttling lever at the driver's hand. The mechanical governors are of two kinds. In the first we have those operated on the "hit-and-miss" prin-

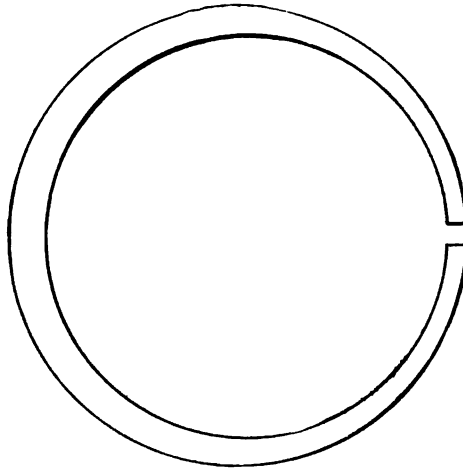

FIG. 285.—Piston Packing Ring for a Gas Engine Cylinder. The inner and outer circumferences are eccentrically arranged, so as to permit of considerable expansion under heat.

ciple, which involves some form of cam and push rod mechanism to be thrown out of gear at high speeds and cause the engine to miss charge or exhaust by opening or closing the exhaust valve, or closing the feed valve during one or several strokes. Such a variety of governing mechanism may also be geared to open the circuit of the sparking current, thus preventing timed ignition. The latter method, however, involves short-circuiting the battery and is seldom used where chemical cells supply the current. A second theory of governor regulation involves mechanical operation of a throttle valve, either for

the pure gasoline supply or for the mixture leaving the carburetter under piston suction. The latter of these is the preferable under most conditions since, unlike the former, it seldom allows the feeding of a mixture that may not be exploded, as must be the case if the original source of gasoline is throttled.

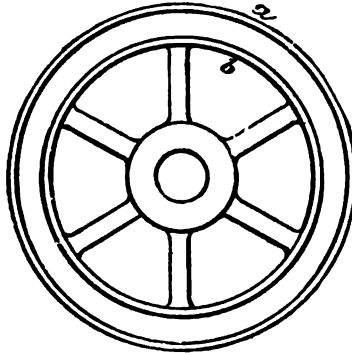

FIG. 286.—Fly-Wheel of an Engine. Since the fly-wheel of a gas engine serves the function of "storing up" energy and equalizing the conditions of operation, its proportions must be carefully calculated. As given by Roberts, the proper weight for a given engine may be found as follows:

$$\text{Weight} = \frac{\text{I. H. P.} \times 111,600,000,000}{(\text{wheel diameter})^2 \times (\text{R. P. M.})^2 \times E}$$

in which E is the co-efficient of permissible unsteadiness. The same authority says that the length of the hub should be between 1.5 and 2.5 the diameter of the crank shaft; and, that the outside diameter of the wheel should be between 4 and 5 times the stroke length, which, with a rim-speed of 6,000 feet per minute, which is the practical maximum, gives the formula:

$$\text{Diameter} = \frac{1910}{\text{R. P. M.}}$$

Here, 1910 is the approximate quotient between 6,000 and 3.14159, or the ratio between the circumference and diameter of a circle.

Construction of the Cylinder and Piston.—The cylinder of an internal combustion motor is open at the front and has the valves for admitting and expelling the fuel at the rear. The piston is always of the "trunk" pattern—a cylindrical box somewhat shorter than its stroke and in length usually about one-third more than its diameter. For smaller types of motor the side walls of the piston are about 5-16 inch in thickness, never less, and the rear end wall is, as a usual thing, somewhat more. The cylinder and piston are machined so as to give a play of about .001 inch, thus allowing the piston to move easily in the length of the bore. In order to further ensure a good fit,

three, and sometimes four, iron rings are inserted in grooves cut in the circumference of the piston near the rear end, and held in position with dowel screws. These piston rings are so made that the external and internal circumferences form eccentric circles, as shown in the accompanying figure. They are also cut open at one point. By this means is secured a play in the grooves of at least 1-32 inch, which allows for expansion and lengthening of the rings under heat of the ignited fuel. The rings are sprung on over the junk rings between the grooves, and when in place should have an outside diameter which can fit the cylinder bore. This bore is usually one or two-thousandths of an inch larger than the outside diameter of the piston. Owing to the fact that the heat produced in an explosive motor cylinder is greater than in a steam cylinder, a slight play is allowed for the rings at the sides.

The Crank and Driving Gear.—In the disposition of the crank and driving connections, the explosive motor differs again from the steam engine. The piston rod in the steam engine slides through the stuffing box in the cylinder head, and the crank is attached to the end at the cross head, which works between guides. The gas engine cylinder, being open at the forward end, has no head or stuffing box and no piston rod proper; in fact, the crank and piston rod are combined in one. The crank is hung on the gudgeon pin fixed midway in the length of the hollow trunk piston, and works on the crank shaft, upon which the fly wheel is secured. Although, as we have already seen, the small steam engines for vehicle use dispense with the fly wheel, such a balance is positively essential in a gas engine of any size or power. The reason for this lies in the fact that the ordinary four-cycle motor, having but one power stroke in every two revolutions of the crank shaft, requires a heavy fly wheel to counteract the speed fluctuations and to "store up" energy sufficient to carry the rotation through the three idle strokes of exhaust, inhaust and compression. For this reason gas engine fly wheels are made much heavier than those designed for steam engine use. Many gas and gasoline motors are also made with two fly wheels, one on either side of the crank pin, which is in fact attached midway on a radius of the two wheels, or "discs," as in all enclosed crank case motors.

CHAPTER TWENTY-FOUR.

THE PRESSURE, TEMPERATURE AND VOLUME OF GASES IN A GAS ENGINE.

Operation of Explosive Motors.—Since an explosive motor operates through the rapid expansion of gas under conditions of combustion, calculations to determine its power and other capacities must be based on considerations of volume, pressure and temperature. As may be readily understood, either of these elements may be taken as a basis for calculations including the others, since, other things being equal, the degree of temperature produces the volume, or the relative tendency to expansion, and the increase of volume to a certain point involves increase of pressure. Thus it follows that the whole cycle of a gas engine is characterized by a proportionate increase, the factors of variation being considered, in the elements productive of power and motion. At the aspirating, or inhaust, stroke, the outward movement of the piston, by creating a partial vacuum, causes the feed valves to open under atmospheric pressure, thus indicating that the pressure within is lower than that of the atmosphere without. At explosion the volume and temperature are raised, and at the end of the scavenging stroke, the exhausted products of combustion are expelled with a force indicative of a pressure several times greater than the atmosphere. The inhaust stroke being completed, and the feed valves closed by force of a spring, there is no considerable increase in volume and pressure due to contact with the hot cylinder walls, nor yet from the residuum of burnt products in the clearance or combustion chamber, although, owing to the valve spring, the pressure of the contained gases is below one atmosphere. As shown by average indicator tracings, the rise in pressure during the inhaust stroke is from a negative point to generally about 13.50 pounds to the square inch. So soon, however, as the compression stroke begins, the indicator tracing shows a steady rise from 14.7 pounds to the square inch, or normal atmospheric pressure, to 65 or 70 pounds at the completion of the stroke, the rise in temperature being on an increasing ratio during the latter half,

although during the first half approximately regular. That the superheated residua of combustion in the clearance, being again compressed, are effective in producing the rapid rise at the end of the stroke is suggested by the fact that the figures for both pressure and temperature are, other things equal, greater for a non-scavenging than for a scavenging engine. At the end of the compression stroke the gas mixture in cylinder has attained its greatest density, also its greatest pressure and temperature previous to combustion. It is then ready for firing, which is accomplished very shortly before the piston begins the second out-stroke, the explosion serving to bring the gas to the maximum point for volume, pressure and temperature alike. In fact, the effect, as shown by thermometer and indicator tests, is that the temperature in a gas engine cylinder rises during this stroke from between 500 and 700 degrees, absolute, as noted when the engine is running at good speed, to between 1,500 and 2,000 degrees, on the average, and the pressure from an indicated 65 or 70 pounds to 200 or 230 pounds per square inch. The fall in both particulars is equally rapid during the succeeding in-stroke, when the burnt gases, under impulse from the piston, are expelled through the open valves. At the completion of this exhaust stroke, accordingly, the same cycle of pressure and temperature transitions is begun again, all superfluous heat units having been carried off in the exhaust and through the cylinder-cooling system.

Regarding the time of firing practice differs considerably. Generally, as stated above, it is slightly before the beginning of the power stroke, in order to allow time for the burning gas to begin expansion. Slow-speed motors are generally fired very slightly after the dead centre. With high-speed motors it varies from about 5 degrees after dead centre to 30 or 40 degrees ahead (as measured on the crank). With a large spark, hot motor and well-mixed fuel, the advanced spark is seldom set more than 15 or 20 degrees ahead.

Principles of Pressure and Temperature in Gases.—As we have already explained in the section on steam engines, a leading property of gases is that, the temperature remaining about the same, an increase in volume involves a corresponding decrease in pressure, and, that to maintain even a constant pressure in an

expanding gas, the temperature must be raised on a steadily increasing ratio. In other words a given cubic content of expanding gas, at a constant temperature, shows a lower pressure per square inch as the expansion progresses, and, in order to obtain a given total, original, efficient pressure the cubic content of the cylinder must increase with the expansion. On the other hand, if a given cubic content of gas be compressed to half its normal volume, without involving an accompanying increase in

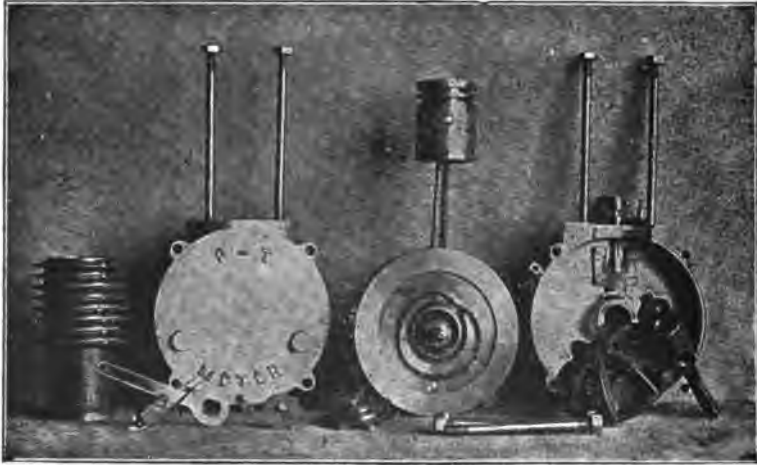

FIG. 237.—The Parts of an Air-Cooled Vehicle Motor, shown for an efficient make of bicycle gasoline engine. The cylinder, carrying radiating ribs, is shown at the left. Next is the outside view of one-half of the crank case; then the trunk piston with the piston rod attached to the crank discs. At the right of the cut is the inside view of the other half of the crank case, with the cylinder head lying in front of it. The crank disc, or fly wheel, shows the double eccentric cam groove for operating the exhaust valve rod, which was a distinctive feature of the earlier Daimler gasoline engines.

temperature, the pressure is doubled. In either case, an undue increase of temperature operates to neutralize the stated principle.

From these facts we may deduce the principles that:

1. The pressure of a gas varies inversely with the volume and directly with the temperature.
2. The volume of a gas varies inversely with the pressure and directly with the temperature.

3. The temperature of a gas varies directly with both the pressure and the volume.

To state these principles in another way, we may say:

1. An increased pressure involves a decreased volume or an increased temperature.
2. An increased volume involves a decreased pressure or an increased temperature.
3. An increased temperature involves an increased volume and an increased pressure.

As the operative conditions in a gas engine are immensely irregular no formulæ can precisely express the proper temperature, volume or pressure for theoretical situations. Since, however, the attributes of the fuel gas at various points in the cycle series are in direct proportion to the dimensions of the cylinder, the length of the stroke, the cubic content of the clearance, and the percentage of atmospheric air in the explosive mixture, very exact figures may be found to express the power and capacity of any particular engine.

Proportionate Figures for Temperature and Pressure.—In the operation of the explosive motor the fuel gas is confined within the cylinder, so long as its properties are significant in calculation on power and speed. The figures for the total cylinder content being then determined, we have a constant standard of comparison for calculating the pressure and temperature of a given mixture of gas and air under the several cycular conditions. For, although the contained gas occupies the same cubic content at the beginning of the compression stroke and at the end of the firing stroke, it is obvious that its proper volume is vastly increased at the latter moment, as indicated by the raised pressure and temperature figures. But, following the principles laid down above, we find that the figures are regular and proportionate as between the initial and final volumes, pressures and temperatures.

The following formulæ express these conditions:

Let P' be the initial pressure.

Let P'' be the final pressure.

Let T' be the initial temperature.

Let T'' be the final temperature.

Let V' be the initial volume.

Let V'' be the final volume.

Then :—

$$\frac{P' V'}{P''} = V''; \quad \frac{P' V'}{V''} = P'';$$

$$\frac{P' T'}{T''} = P''; \quad \frac{T' P''}{P'} = T''.$$

From these formulæ we may deduce the obvious rules that :

1. The final volume divided by the initial pressure is equal to the final pressure divided by the initial volume; or, the final volume divided by the initial pressure is equal to the initial volume divided by the final pressure. Having reduced this to a definite basis we have it that the final volume equals the quotient found by dividing the product of the initial pressure and initial volume by the final pressure.

2. On precisely similar lines, the final pressure equals the quotient found by dividing the product of the initial pressure and initial volume by the final volume.

3. The final pressure also equals the quotient found by dividing the product of the initial pressure and final temperature by the initial temperature.

4. The final temperature equals the quotient found by dividing the product of the initial temperature and final pressure by the initial pressure.

In calculating practical figures the initial volume, pressure and temperature may be those taken at the beginning of the compression stroke, when the figure for volume is at the highest point and the figures for pressure and temperature are at the lowest points, independent of any external agency that can modify them. The formulæ given above may be used for calculating between the initial point and any subsequently following by comparing its figures with the figures found at that given point. In practice, however, they are always used in connection with the absolute figures for pressure and temperature, next to be described.

Absolute Figures for Pressure and Temperature.—As is obvious, the proportions of the cylinder content, stroke and clearance are always constant and known. Those for temperature may be found on the thermometer scale: those for pressure, by the indicator gauge. In practice, however, it is customary to use "ab-

solute figures," as they are called, which represent the sum of the thermometric or the gauge figures with certain constants determined by calculation and experience. Thus the absolute pressure is the gauge pressure plus 14.7, which is the atmospheric pressure in pounds per square inch. The absolute temperature is the



FIG. 288.—A Daimler Single-Cylinder Motor Intended for Stationary Use. Attached to the head of the water-cooled cylinder are the gasoline chamber and carburetter. The lubricating cup is shown immediately below. The exhaust valve, not shown, is operated by a cam on the secondary shaft, geared to the crank shaft, as may be seen within the fly-wheel. In essential particulars this motor is identical with those used for vehicle propulsion; the method of mounting being, of course, different.

sum of the sensible thermometric temperature and the constant 461. This latter figure, which is properly expressed as 460.66, represents the total number of degrees on the Fahrenheit scale from 32° below the freezing point of water to the absolute zero of temperature, as calculated by the expansion ratio of gases.

Thus, in calculating temperatures in gas engine practice, the custom is to count from absolute zero. For example, instead of 64° , writing 525° , and instead of 32° , writing 493° , or, more correctly, 492.66° . The utility of this system lies in the fact that, as a gas has been found to expand by 1-273 of its original volume for each degree, centigrade, or by 1-461 for each degree, Fahrenheit, of increased temperature, we have by the use of absolute figures an approximate expression for both increased heat and increased volume in the same number.

On a scale giving as a unit one part out of 493 for 32° , and one part out of 525 for 64° , we have a co-efficient of expansion that is capable of ready verification. The same line of reasoning holds good for pressure calculations, which start from a theoretical zero at the beginning of the inhaust stroke, and are, theoretically, reducible to atmospheric conditions only by the addition of the 14.7 pounds per square inch. For this reason tables giving the pressure series for gas cylinders of various proportions at the end of the compression stroke most often start from the theoretical one pound pressure per square inch, which column gives the figures to be multiplied by the ascertained pressures at the beginning of the compression stroke for any given motor.

Measuring the Conditions of Operation.—The factors entering to vary the figures, with the same initial pressures in different engines, are the ratio of compression and the percentage of the clearance volume, as compared with the total cylinder volume. The ratio of compression is found to be equal to the quotient of the total volume of the cylinder from the beginning to the end of the stroke, including also the clearance, divided by the volume of the clearance, which, as is evident, is never decreased during any portion of a stroke. The percentage of the clearance volume is similarly found by dividing the volume of the clearance by the volume of the piston displacement: in other words, it is the quotient of the cubic content of the clearance, from the rear of the cylinder to the rearmost reach of the piston at the end of an in-stroke, divided by the cubic content of that portion of the cylinder included between the inmost point of the in-stroke and the outmost point of the out-stroke, as indicated by the position of the rear end of the piston at those two points. Having ascertained these proportions for any given engine the *absolute figures*

for operating pressure and temperature may be readily found. Thus, in order to find the pressure per square inch at the end of the compression stroke, it is necessary only to multiply the figure corresponding to an engine with the given compression ratio and percentage of clearance by the ascertained gauge pressure at the beginning of the stroke, or any other required pressure at the same point. Thus the initial pressure at theoretical unity for a cylinder having a compression ratio of 3 and a clearance percentage of 50 is 4.407, which multiplied by 13, the gauge or desired pressure, gives 57.29; by 13.2, gives 58.17; by 13.5, gives 59.49; by 14, gives 61.69; by 14.7, gives 64.78.

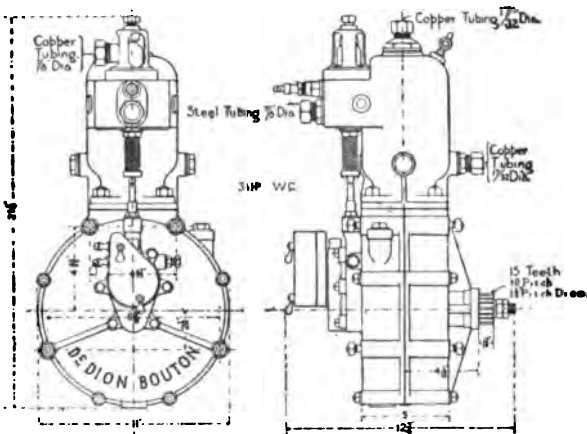

FIG. 260.—Rear and Side Elevation of a De Dion Water-Cooled Carriage Motor, showing method of joining the two halves of the crank case and bolting them to the cylinder. As indicated, also, the water-jackets, cylinder head and valve chamber are cast integral with the cylinder.

The compression temperature is similarly determined by multiplying the found or required absolute temperature at the beginning of the stroke by the figure for one degree for a type of engine having the same compression ratio as the one in question. Thus, for an engine having the ratio at 3, the theoretical initial temperature is estimated as 1.46° , which, for an initial absolute temperature of 525° gives 766° , and for 560° gives 822° .

Since these processes are of importance in calculating the power of a gas engine, it is well to enter into the general principles involved, as introductory to a more extended study of the subject. The cubic content of a cylinder, together with the con-

tent of the stroke and clearance areas may, of course, be calculated by knowing the diameter and length of the cylinder and the length of the stroke. A more practical method for unskilled mathematicians and mechanics is that suggested by E. W. Roberts in his "Gas Engine Handbook." As described by him the process is, briefly, to turn the crank to a dead center and close the valves, and then fill the cylinder with water. By altering the position of the piston rod from in-stroke end to out-stroke end, the cubic content of both clearance and total cylinder may be accurately estimated. The water having been weighed before pouring it into the cylinder, the weight of that left over is a ready indication of the weight of that within. Now, as is well known, water at a temperature of 39.1° weighs 62.5 pounds per cubic foot. Thus, when the temperature of the water is higher than 39.1° its weight per cubic foot may be found by the following formula, in which T is the thermometric temperature, 461, the constant of absolute temperature, and 500, the absolute temperature of water at 39.1°.

$$\frac{62.5 \times 2}{\frac{T + 461}{500} + \frac{500}{T + 461}} = \text{Weight per cubic foot.}$$

This formula is particularly convenient where the cylinder has a spherical or enlarged combustion chamber, which would involve mathematical processes of considerable intricacy to properly estimate its content. As it is, the only requirement is that we substitute the ascertained temperature figures for T wherever it occurs; reduce the fractions to a common denominator, and perform the indicated additions and divisions.

Application of the Formulæ.—Taking the fuel gas at constant volume—this is theoretically the condition in the gas engine—and raising its temperature through a certain number of degrees involves a proportionate increase in pressure. Thus, knowing the initial and final temperatures, we may derive the gauge pressure of compression, since the pressure of a gas is in direct ratio to the temperature. If from an absolute initial temperature of 525° (64° plus 461) we have a final temperature of 2161° (1700° plus 461), the increase or acquired temperature is 1636°. Beginning at 525°, the ratio of increasing volume and

temperature is 1-525th, or .0019047. Then, multiplying together the ratio thus found, the acquired temperature and the absolute initial pressure (14.7), we have the gauge pressure of compression, which is 45.80 pounds to the square inch. As may be readily demonstrated by performing the same operations with other initial and final figures, the initial pressure is in strict proportion to the volume and temperature. Other things being equal, therefore, it might seem reasonable to lay down the rule that, the higher the pressure of compression, the greater the rise in temperature at the point of ignition and, consequently, the greater the efficiency in units of work. Accordingly, we find that, while in many early gas engines this pressure was very much below fifty pounds to the square inch, with the more modern and improved patterns it strikes an average in the neighborhood of seventy pounds. It must not be forgotten, however, that this rule has very definite limitations, and that beyond a certain point of increased compression pressure the efficiency ratio begins to decrease rapidly. As has been already suggested, the ratio of compression is to be calculated on the proportions existing between the clearance, or combustion chamber, and the total effective length of the cylinder, as shown by the area of the piston sweep, or stroke. Consequently a decrease in the clearance content involves, to a certain point, a proportionate increase in the ratio of compression, with commensurately higher temperature and efficiency. Thus, applying the rule for calculating the compression ratios of two cylinders, in which the clearance and total content are in proportion of 2 to 4 and 1 to 4, respectively, we derive the following expressions :

$$\frac{2 + 4}{2} = 3 \qquad \frac{1 + 4}{1} = 5$$

Such a result may come either from decreasing the clearance, increasing the stroke sweep, or varying the figures in both particulars.

Taking a theoretical one pound pressure and one degree temperature, initial, we have the following figures for varying compression ratios in non-scavenging engines, derived as above :

With a ratio of 3, we have 4.407 for pressure and 1.4689 for temperature ; with 4, we have 6.498 and 1.6245, respectively ; with 5, we have 8.783 and 1.7564 ; with 6, in the same way, 11.233 and

1.8722. These figures, multiplied by the ascertained initial pressure and temperature in any particular engine of the same ratio, will give the proper figures for that engine. Fractional figures range between those given. In a scavenging engine—one that is constructed to expel the whole of the burned products, although never fully accomplishing the result in practice—the clearance ratio is virtually an expression for the total cubic content swept by the piston. Since, then, the stroke-sweep of an engine is the one consideration, as compared with engines of different proportions in this particular, we should have, theoretically, about the same degree of pressure and temperature as are given above. As estimated by several authorities, however, the figures vary somewhat. Thus, as before, for scavenging engines at the theoretical unity for initial pressure and temperature, with a ratio of 3, we have 4.264 for compression pressure, and 1.4213 for compression temperature; for 4, we have 6.233 and 1.5707, respectively; for 5, we have 8.368 and 1.6737; and for 6, we have 10.646 and 1.7742. The figures seemingly indicate a difference of rise in temperature and pressure due to the recompression of burned gases that is about .2 degree for a compression ratio of 3, and .1 degree for a compression ratio of 6, as found in the former type of engine over the latter. If this conclusion is correct, as some authorities seem to question, we find that the heat efficiency of the burned gases, as found at the end of the compression stroke, is in inverse proportion to the length of the stroke in any given engine, indicating the greater loss of heat units to the jacket water of the cylinder in the motor of proportionately longer stroke. Since, then, the quantity of burned and expanding products is naturally smaller in the scavenging cylinder than in one of the other type, we can readily understand how that the figures for compression pressure and temperature are higher for the latter than for the former, as possessing an absolutely greater internal efficiency for heat and pressure.

Figures on Compression Pressure.—On the matter of compression figures this quotation from Hiscox will suffice:

“It has been shown that an ideal efficiency of 33 per cent. for 38 pounds compression will increase to 40 per cent. for 66 pounds, and 43 per cent. for 88 pounds compression. On the

other hand, greater compression means greater explosive pressure and greater strain on the engine structure, which in future practice will probably retain the compression between the limits of 40 and 60 pounds.

"In experiments made by Dugald Clerk with a combustion chamber equal to 0.6 of the space swept by the piston, with a compression of 38 pounds, the consumption of gas was 24 cubic



FIG. 290.—A Typical American Gasoline Carriage—the Packard Racer.

feet per indicated horse-power per hour. With 0.4 compression space and 61 pounds compression, the consumption of gas was 20 cubic feet per indicated horse-power per hour; and with 0.34 compression space and 87 pounds compression, the consumption of gas fell to 14.8 cubic feet per indicated horse-power per hour—the actual efficiencies being respectively 17.21 and 25 per cent. This was with a Crossley four-cycle engine."

CHAPTER TWENTY-FIVE.

THE METHODS AND CONDITIONS OF GAS ENGINE CYLINDER COOLING.

Rate of Gas Consumption.—As given by several authorities, who base their calculations upon engines possessing the most favorable conditions in the respects above enumerated, and using the fuel best suited to the end in view, the average of gas consumption per horse-power per hour is 20 cubic feet, although, as may be readily understood, such figures vary with the kind and quality of fuel and the proportions in such matters as are mentioned by Hiscox, as above quoted. There are, however, other considerations entering into the judgment of ideal efficiency and some of these we will proceed to treat.

The Conditions of Efficiency.—The efficient power of a gas engine is not a matter dependent wholly, or even largely, on relative proportions among any of the working parts, and, at most, the figures given above are averages for the best obtainable conditions. Such favorable conditions consist very largely in such economy as may be obtained by keeping the jacket water at proper temperature—the higher temperatures at a few degrees below the boiling point seem best calculated to prevent over-absorption of heat units at every stage of the cycle—and to such as may be obtained by securing fuel mixtures and conditions favorable to rapid ignition. Bearing in mind these elements of variation in our estimates on power, we may readily understand that the efficiency of a gas engine is expressed by “the ratio of heat units turned into work, as compared with the total heat produced by combustion.” By far the greater proportion of gas engines—those employed alike for general power purposes and in propelling motor vehicles—have water-cooled cylinders; the water for this purpose being admitted to a jacket or water space cast around the cylinder's circumference, and circulating between that space and the feed-tank or cistern, in accordance with the laws of liquids, which cause the heated layers to rise from the bottom to the top of the reservoir, and the cooler layers

to fall correspondingly. As stated above, the foremost utility subserved by this arrangement is that the temperature of the cylinder is normally maintained below the point at which the lubricating oil will otherwise carbonize. Furthermore, the walls would also become so heated that the fuel charge would be fired out of time, with the result of disarranging the cycle and rendering the engine inefficient. That this result would follow is practically demonstrated in engines of the Hornsby-Akroyd type, wherein, instead of any spark, tube or other timed devices to fire the charge after the cylinder has fairly taken up its cycle, the heated walls of the combustion chamber provide the necessary temperature under cycular conditions. This combustion chamber is unjacketed and connected to the jacketed cylinder chamber by a passage of small diameter, so that only a minute portion of the contents of either will mix freely, except under compression. During the aspirating stroke of the piston the gas mixture is fed into this unjacketed chamber, and the air into the cylinder space, with the result that, no portion of its heat being absorbed by jacket water, the temperature is raised to the firing point of the fuel by the mixture of air under the added pressure of the compression stroke. This result generally follows after the firing of one charge by external means of raising the temperature, and is to be attributed most largely to the absence of the water-jacket. Thus, although the "cooling system" is a positive necessity in the space swept by the piston, for the reasons above stated, it forms a serious consideration in estimates on efficiency by absorbing a large proportion of the heat units generated by ignition of the fuel, and thus, under any conditions operating to reduce the total efficiency, even though by only a fractional ratio.

Jacket Water: Its Rate and Quantity.—On this point Hiscox makes an interesting statement on the proportions of absorbed and efficient heat units, as estimated under typical conditions. He says:

"In regard to the actual consumption of water per horsepower and the amount of heat carried off by it, the study of English trials of an Atkinson, a Crossley, and a Griffin engine showed 62 pounds of water per indicated horse-power per hour, with a rise in temperature of 50° F., or 3,100 heat units carried off in the

water out of 12,027 theoretical heat units that were fed to the motor through the 19 cubic feet of gas at 633 heat units per cubic foot per hour.

"Theoretically, 2,564 heat units per hour is equal to one horse-power. Then, 0.257 of the total was given to the jacket water, 0.213 to the indicated power, and the balance, 53 per cent., went to the exhaust, radiation and the reheating of the previous charge in the clearance and in expanding the nitrogen of the air. * *

"In a trial with a Crossley engine, 42 pounds of water per horse-power per hour were passed through the cylinder jacket, with a rise in temperature of 128° F.—equal to 5,376 heat units

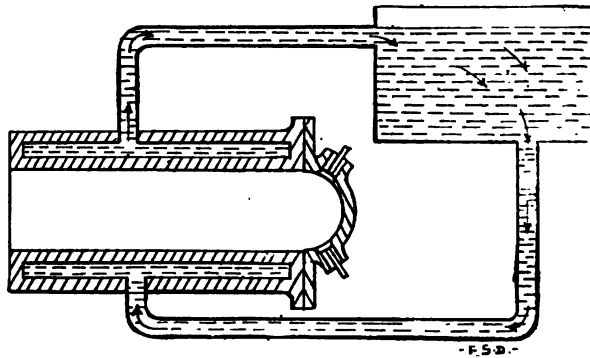

FIG. 291.—Sectional View of the Water Jackets and Water Circulation Connections of a Gas Engine Cylinder, in which the circulation operates through gravity. The arrows indicate direction of circulation current.

to the water from 12,833 heat units fed to the engine through 20.5 cubic feet of gas at 626 heat units per cubic foot.

* * * * *

"An experimental test of the performance of a gas engine below its maximum load has shown a large increase in the consumption of gas per actual horse-power, with a decrease of load, as the following figures from observed trials show: An actual 12 H. P. engine at full load used 15 cubic feet of gas per horse-power per hour; at 10 H. P., 15½ cubic feet; at 8 H. P., 16½ cubic feet; at 6 H. P., 18 cubic feet; at 4 H. P., 21 cubic feet; at 2 H. P., 30 cubic feet of gas per actual horse-power per hour. This indicates an economy gained in gauging the size of a gas engine to the actual power required, in consideration of the fact that the

engine friction and gas consumption for ignition are constants for all or any power actually given out by the engine."

Gas Consumption and Power Efficiency.—Such facts bring us to an interesting situation in regard to estimating for the highest power-efficiency in a gas engine. As has already been stated, an increase in compression, involving a smaller combustion chamber or a longer stroke, ensures a higher temperature and explosive force at ignition. But, in obtaining these ends by such relatively longer piston-sweep, we are met by the difficulty incident upon exposing the ignited gas to a commensurately larger area of heat-absorption through the circulating jacket-water. As it is impracticable to leave any portion of the sweep space unjacketed, it is obvious that economy in this respect must be obtained by some mechanical or physical variation in the con-

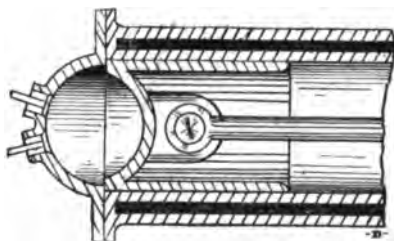

FIG. 292.—Section through a Gas Engine Cylinder having a spherical clearance and a spherical depression on the piston head. The shaded sections at top and bottom indicate the water jackets.

ditions. Thus, for example, considerable economy in fuel-consumption may be obtained by increasing the speed of the engine, which, when the cycle is well established, involves that the explosive impulses succeed one another so rapidly that the percentage of heat units absorbed by the jacket water is constantly reduced. This fact is shown by the data above quoted for a 12 H. P. engine, driven successively at 10, 8, 6, 4 and 2 H. P. and showing an increase in gas-consumption per horse-power in inverse ratio to the effective power-output. Such a reduction of power-output involves, of course, a lower speed, and is accomplished by regulating the gas and air supply. But if, according to the figures quoted above, a 12 H. P. engine at full power consumes 15 cubic feet of gas per horse-power per hour, which is 180 cubic feet per

hour, it will at 10 horse-power consume 155 cubic feet, or 86 per cent. ; at 8 horse-power, 132 cubic feet, or 75 per cent. ; at 6 horse-power, 108 cubic feet, or 60 per cent. ; at 4 horse-power, 84 cubic feet, or 46 per cent., and at 2 horse-power, 60 cubic feet, or 33 per cent. The waste in fuel gas under low speed and low power conditions may thus be readily understood—one-sixth of the stated horse-power from one-third of the full gas supply. It may thus be understood why that the speed of the engine, usually expressed as "revolutions per minute" of the fly-wheel, is an important item in all formulæ for calculating the horse-power. The gas engines built for automobile use are invariably of high speed-capacity, and also represent the highest point of economy.

Because of the fact that a reduction of the charge involves a nearly corresponding loss of power output in a gas engine, it is usually believed that the speed of the carriage can be varied only by the change-speed gear. On this point, however, Mr. C. E. Duryea says :

"In order to vary the speed of a carriage on a given road, it is necessary to vary the fuel supply, because if the lower gear is used, the engine, having less work, will race and the governor must then act, which is a method of varying the fuel supply. The speed-changing gear is provided in connection with gasoline engines, because such engines are not provided with variable cut-offs and are, therefore, not considered economical with various sized charges. On this account a motor of average size is used, and its deficiencies made up for by change of gearing. The Duryea practice is to provide a large motor, just as is done with a steam engine, and to throttle it over a wide range regardless of the loss of economy. As a matter of fact, this loss is more seeming than real, for, with the speed-changing mechanism, a constant mechanical loss is present which balances largely, if it does not exceed, the efficient loss of the motor by throttling. We are, therefore, able on good roads to drive our carriages at from three to thirty miles per hour by varying the speed of the motor by a throttle, and we use the gearing only for hills that are beyond the capacity of our motor as ordinarily geared."

Heat Economy: Spherical Clearance.—A number of gas engines achieve an economy in the use of heat and power units by having the piston and the combustion chamber of concave

profile, so as to form a spherical, spheroidal or elliptical clearance at the end of the in-stroke. That is to say, the rear end of the cylinder is dome-shaped and unjacketed, and the opposing end of the trunk piston is correspondingly hollowed or concaved. The spheroidal clearance, formed when they are in contact or proximity, is, of course, deformed as the piston makes its out-stroke, but the end of economizing a considerable percentage of heat units is conserved by thus providing a large uncooled surface at either end of the combustion chamber during the entire cycle. Indeed, while this arrangement permits of a clearance, at the end of the in-stroke, of the smallest possible area on the cylinder

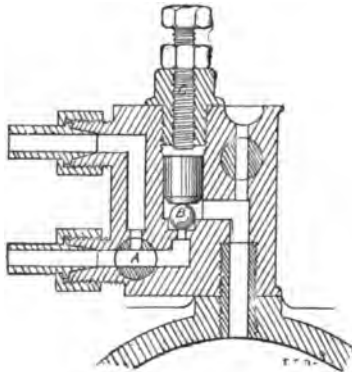

FIG. 293.—The "Lombard" Improved Cylinder Cooling Device. Instead of wing flanges, or jacket water, this system provides for cooling the cylinder by injection of a small quantity of water, atomized by suction of the piston. This water comes through the lower tube to the left of the cylinder head, passing through the three-way cock, A, and the ball valve, B. The lift of the ball valve is determined by the adjusting screw, C. When water is not required, the three-way cock is turned so as to return it to the tank through the upper left-hand tube. The theory is that superfluous heat will be absorbed in vaporizing the injected water.

walls, it provides a total increase in clearance volume on a stated wall surface between 20 and 40 per cent. in engines of ordinary design. Hiscox estimates that, while the wall surface of a cylindrical clearance space of one-half its unit diameter in length contains 3.1416 square units and 0.3927 cubic unit, the same surface in square unit measure, with a spherical combustion chamber has a volume of 0.5236 cubic unit, representing a gain in volume of 33.1-3 per cent. ($5236 - 3927 = 1309 \times 3 = 3927$). Such superior volume, on equal wall surface, being fully available at the moment of explosion, when the greatest possible degree of heat

and pressure is desirable to promote expansion, must vastly increase the effective power of the engine. Furthermore, although this arrangement is perfectly satisfactory in checking the absorption of heat units until the full force of the explosion has been realized, it is ineffective for producing a hot surface, firing temperature, such as is seen in the Hornsby-Akroyd engines, from the fact that the concave surfaces of cylinder end and piston head are open to a large heat-absorbing space, and hence quickly fall in temperature.

Heat Economy: Temperature of Water.—Another consideration of importance in calculating for heat economy in a gas engine is that the temperature of the jacket water should be maintained at a point favorable to moderate absorption of heat

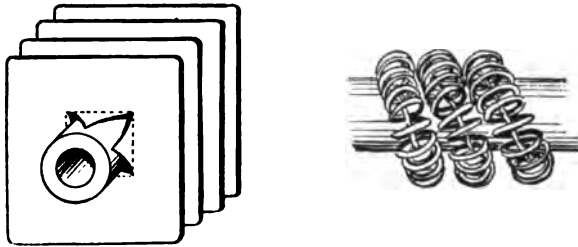

FIG. 294.—Details of Two Descriptions of Water Cooling Radiators. In the first, the pipe is surrounded by metal fins, let on as indicated; in the second, it is surrounded with coils of helical wire.

units. It is an error of somewhat common occurrence to suppose that the conditions of cycular operation demand that this temperature be as low as possible; the popular notion being that the cylinder requires some kind of *freezing* process in order to be properly "cooled." As we have already stated the real object of the cylinder cooling system, it is necessary only to add that the requirement is that the temperature should be kept somewhat below a definite high point, and that, as can be readily understood at this stage, the efficiency of the engine is decreased very nearly in proportion to the thermometric fall below that point. Thus if we play a jet of water from an ordinary garden hose upon a gas engine in operation, we will very quickly discover that its motion is effectually checked; whereas, if we supply the jacket system with water of slightly below 100°, Centigrade, we will

discover that the efficient power is increased in ratio with the rise in temperature. Thus, as is being advocated by some of the foremost authorities on the subject, the best practice is to supply water to the jacket at a temperature of a few degrees below the boiling point, permitting it to be returned to the reservoir at a temperature slightly above. Some hold that even higher temperatures are practicable.

A well-known manufacturer of gasoline carriage motors writes as follows: "A motor is hotter when the water is boiling rapidly than when it is boiling slowly, and the fact that more

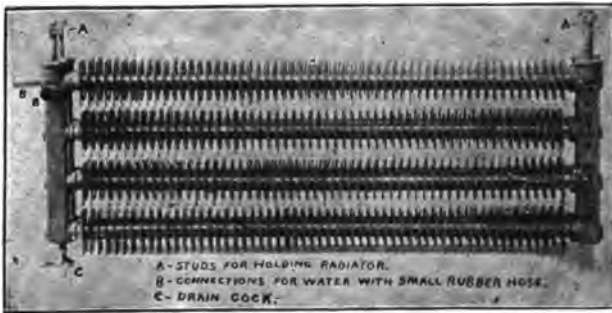

FIG. 295.—Fin Cooled Radiating Tubes used on the "Dyke" Carriages, with parts and connections indicated.

heat units are being absorbed by the water proves that the engine is doing harder work and not that it is cooler than before. The writer favors boiling water as the proper temperature and a gravity circulation as the proper circulating method, because this method most nearly insures a fixed temperature for the motor to work under. If kept below the boiling point the temperature of the motor will vary as the work varies. If air-cooled it will vary with the wind or the speed of the vehicle. If circulated by pump the temperature will vary as the speed of the pump varies, but with the boiling water system it remains reasonably constant and permits the finest adjustment of the mixture and the best results from the sparking." Other authorities seem to disagree with his position.

Heat Economy: Rate of Water Circulation —In the excellent and suggestive treatise on "Gas and Oil Engines," given in

"Power Quarterly," for October, 1900, occurs the following significant passage:

"The more rapidly the water passes through the jacket, the lower will be the temperature of the issuing jacket water, but the heat units will be greater, within the usual limits of practice. For example, suppose the jacket water passes through at the rate of 16 pounds a minute and rises from 60° F. to 140° F. in passing through. To raise 16 pounds of water 80 degrees requires 1,280 B. T. U. (British thermal units), and as the difference between the



FIG. 233.—"Crest" Double-Opposed Cylinder Gasoline Vehicle Engine, showing radiating ribs for cooling cylinders. The cylinders of this motor are in line, not off-set, as in some makes, the two cranks working on one crank pin. Owing to the method of joining the crank case on its diameter, all the working parts may be readily reached by unscrewing four bolts. Among the special features of this motor are the relief valve, which opens, hence interrupting operation as the wagon coasts down hill, and the automatic cut out for the battery circuit which operates when the engine is at a standstill.

average temperature within the cylinder (usually about 1,000° F.) and that of the jacket water (in this case 100°) is 900 degrees, there are 1,422 heat units per minute transmitted through the walls of the cylinder per degree of difference between inner and outer average temperatures.

"Now reduce the rate of flow of the jacket water to 9.57 pounds, and, assuming that the average temperature in the cylinder remains constant, the water will issue at a temperature of 190° F. This means a rise of 130 degrees, and to heat 9.57 pounds of water per minute 130 degrees, will require $9.57 \times 130 = 1,244$ heat units per minute, which is 36 less than before. A saving of 36 heat units per minute means

$$\frac{36 \times 778}{33,000} = .8487 \text{ H.P., gross.}$$

"As a matter of fact the flow of water would need to be less than $9\frac{1}{2}$ pounds a minute in order to raise the temperature to 190° F., because as the jacket water increases in temperature, the average temperature in the cylinder increases, making the difference between the two less than if the internal temperature remained constant. This decreases the transmission of heat units to the water. The effect of varying the flow of jacket water cannot be computed accurately, because the internal temperature cannot be computed, and the exact heat conductivity of the cylinder walls is unknown. But, as the foregoing rough example clearly shows, the temperature of the issuing jacket water should be kept as high as practicable by adjusting the rate of flow.

"The limit to the allowable increase in jacket water temperature is set by the cylinder oil. The cylinder walls must not be allowed to become so hot as to decompose the oil, for the very obvious reason that decomposed oil does not lubricate. When the construction of an engine is such that the piston cannot be inspected there is no reliable way of determining the conditions of lubrication at high temperatures without endangering the cylinder wall and piston surface. But, as a rule, the jacket water can be run up to 200° F. without risk of decomposing the cylinder oil, if a first-class oil is used."

Such principles as have been mentioned thus far are competent in evidence for the statement that the operative conditions of the gas engine strike a balance between very definite extremes in several particulars, which, if not carefully noted, quickly reduce both the motion and the effective power-output. We have scarcely stated that the cylinder must be regularly cooled, when we are obliged to modify the assertion by saying that it must not be *too cool*, nor yet *too hot*, lest the very difficulties we aim to avoid occur with even greater danger. The same dilemma is met in the attempt to provide against the over-absorption of heat units by regulating the circulation rate of the jacket water: If the rules for ensuring economy are carried too far the good effects of the cooling are neutralized. Water in a paper bag may be boiled over a gas flame, because it absorbs heat faster than does the paper. In the same way, by the use of a water cooling system, a temperature very near to the melting point of steel (2560° F., 3021° absolute) may be reached at the explosion moment of the fuel gas in the cylinder, without destroying the engine or decom-

posing the lubricating oil, which carbonizes usually at a temperature of about 1,000°, Fahrenheit, more or less.

The Limitations of Air Cooling.—From what has already been said it may be possible to understand why that air-cooled cylinders are so seldom used on motor vehicles, particularly such as are of high power requirements. The small one and two indicated horse-power engines made for motor cycles operate very well with this system under ordinary conditions, particularly when the atmospheric temperature is low, or when a draught is

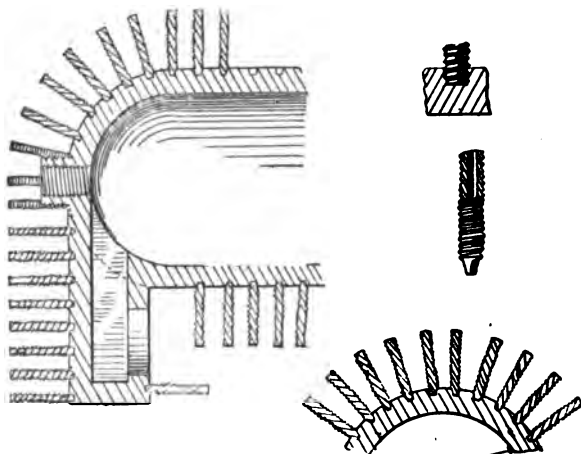

FIG. 297.—The "Knox" Pin-Cooled Cylinder. In this engine, pins are used for radiating instead of the usual flanges or ribs as on other air-cooled cylinders.

created by traveling against the wind. When, however, the weather is unusually warm the air-cooled cylinder is liable to become so hot that the motor operation falls below the required point of both speed and power; owing principally to added friction, to rarefaction of the charge, or to premature ignition. Any one of these conditions can bring the engine to a full stop sooner or later.

Flange-Cooled Cylinders.—As may be readily understood, the object attained by providing the outside of the cylinder with peripheral or longitudinal flanges is a total area of cooling surface many times greater than that of the wall itself. By this

means, of course, the rate of heat absorption is greatly increased, on precisely the same principle as that by which the heating surface of steam boilers is enlarged by the use of "fingers," Field tubes, water tubes, multiple flues, and other similar devices for increasing the total surface exposed to the fire. Indeed, in some automobile carriages using water-cooled cylinders, the water tank is pierced by horizontal or inclined tubes, which, admitting the air under draught of travel, serve to absorb superfluous heat in the water on precisely the same theory as that by which the water is heated in a flue boiler. From the causes just mentioned,

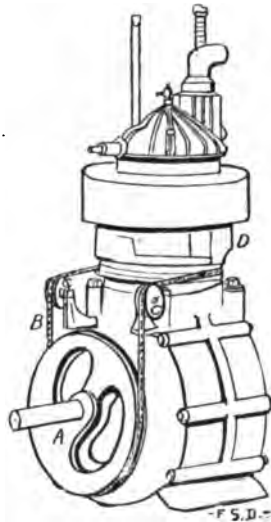

FIG. 298.—The "Kainz" Motor, showing rotary cooling fan about the cylinder. The fan cylinder, D, is rotated by a cord, B, turned by the pulley, A, on the crank shaft and passing over pulleys, C, C.

however, the usual flange-cooling system has grave limitations—the cooling surface thus afforded is insufficient for the requirements, particularly in hot weather. One noteworthy improvement in this particular is the Knox radiating cylinder cooler, which has, instead of the usual ribs or flanges, a large number of brass pins, threaded and screwed into suitable holes in the cylinder walls. According to claims, this device increases the total cooling surface by very nearly 100 per cent., and is exceedingly efficient in utilizing the heat-absorbing properties of air under

draught. Since, however, the specific heat of air is so much lower than that of water—water is 1.00, air is 0.1685 at constant volume—any device for increasing the cooling surface of an air-cooled cylinder is, at best, much less effective than a water-cooling system.

Fan-Cooled Cylinders.—Some motors for cycles, notably the early Daimlers and the Simms, have been supplied with rotary fans, which produce a mechanical draught, being propelled by the engine. Such a device has been found moderately serviceable for engines of small power, but the added weight and mechanical complication involved preclude its use on engines above 1 or 2 H. P. Above that power, at any rate, it rapidly becomes evident

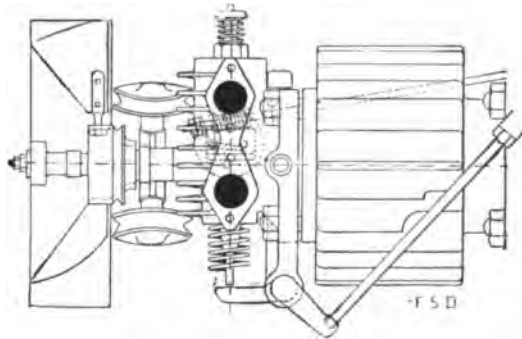

FIG. 299.—Detail Cylinder Head of the Simms Cycle Motor, showing fan wheel, cooling ribs, and peculiar arrangement for opening the exhaust. Similar fan wheels are used on several types of light vehicle motor.

that a well-arranged system of water-circulation is much more effective and economical; may be depended on under all ordinary circumstances, and is altogether simpler and more manageable.

Superiority of Water-Cooling System.—Very largely on account of the considerations just enumerated, practically all gasoline motor carriages are supplied with the water-cooling system, although it involves added weight and a greater quantity of appliances. With the gas engines used for stationary power purposes, the jacket water may be drawn from and returned to a special tank or reservoir, thus ensuring sufficient circulation to regulate the temperature of the water fed to the jacket, but with many vehicle motors is used a supplementary radiating cooler,

through which the ejected water passes on its way back to the tank. The most approved form of such a cooler, as used at present, consists in a coil or train of copper tubes, on which are sprung rows of fins, or flanges, of tin or aluminum. Another form has the same train of tubes spirally corrugated and wrapped about with lengths of wire rolled into very nearly the shape of a spiral spring. The fins, or flanges, just mentioned consist of a number of metal discs, in the center of each of which an X-shaped cut is made. The points thus formed, being bent back, leave an orifice for introducing the tube, and when the discs are in place serve to keep them at proper distance. The fins afford a large heat-radiating surface for the water tubes, which is further increased by so lengthening and coiling the pipes as to expose the greatest possible surface to the air, under draught.

The circulating pump is most commonly used in the belief that it affords a ready means for regulating the rate and temperature of the jacket water supply, which could not always be the case with a mere gravity system. Such, however, is not precisely the case; since such pumps, being generally driven direct from the motor, operate at a speed varying with the motor speed. Thus, on starting the motor, it begins pumping cold water into the jacket, although no occasion exists. It pumps slowly at slow speeds, although the motor may be taking large charges and heating itself rapidly, as when ascending steep hills. It also pumps rapidly at high speeds, although the wind pressure and cooling effect may be very great, as on smooth roads. Could such circulation pumps be always used in connection with a thermostat, in order to operate to the even regulation of the motor temperature, the results would be much more favorable.

In order to prevent freezing the jacket water, when the engine is not in operation in cold weather, solutions are used, notably of glycerine and of calcium chloride (Ca Cl^2). The proportions for the former solution are equal parts of water and glycerine, by weight; for the latter, approximately, one-half gallon of water to eight pounds Ca Cl^2 , or a saturated solution at 60° , Fahrenheit. This solution ($\text{Ca Cl}^2 + 6 \text{H}^2 \text{O}$) is then mixed with equal parts of water, gallon for gallon. Many persons complain that Ca Cl^2 corrodes the metal parts, but this warning need do no more than urge the automobilist to use only the chemically pure salt, carefully avoiding the "chloride of lime" (Ca O Cl^2).

CHAPTER TWENTY-SIX.

ON FUEL MIXTURES AND THE CONDITIONS RESULTING FROM COMBUSTION OF THE CHARGE.

Causes of Imperfect Combustion.—In addition to the general conditions of gas engine efficiency thus far given, it is important to consider the cause and consequences of imperfect combustion, which, as may be readily understood, is a fertile source of irregular action and loss of power. In the first place, it is important to consider the matter of proper proportions of air and gas in the fuel mixture, since too much or too little of either element results in weak explosion. Practically, this is a question of proper carburization, and may be determined by experience quite as efficiently as by calculations. In the second place, sufficient compression of the fuel gas should be provided for, in order that, despite the presence of the exhausted products of previous combustion, there may be an adequate mixture of the charge, giving a fair degree of uniformity throughout. The result of an uniform mixture is to provide one condition of rapid firing, since the gradual and partial combustion, so frequently a source of annoyance and lost efficiency in gas engines, comes directly from imperfect mixture under compression. This brings us to the third point—what method of firing is the most efficient in securing the quickest possible combustion? The first point involves several important considerations, which we will now proceed to touch briefly; the second is largely a matter of structural proportions, after the question of proper mixture has been determined, as is indicated by much already said; the third will be fully discussed under the head of firing devices.

The Theory of Fuel Mixtures.—The object of mixing atmospheric air with the fuel gas is to obtain a sufficient amount of oxygen to enable combustion to take place. All oils and spirits may be ignited and burned at the proper temperature, differing for each particular substance, if that temperature be produced where air can circulate freely. At certain definite temperatures such liquids give off inflammable vapors, and at a somewhat

higher point may be ignited and burned themselves. The first point is called the *flash point*; the second, the *fire point*. However, when shut off from air supply, neither the vapor, so formed, nor the liquid itself may be ignited. This is the reason why that oil vapor may be fed into the superheated combustion chamber of the Hornsby-Akroyd engine, as already described, and fail to explode until, by the completion of the compression stroke, a sufficient quantity of atmospheric air has been mixed with it.

In order to illustrate, the following list of several familiar hydrocarbons, together with their flash and fire points, is quoted from a well-known authority :

	Flash Point.	Fire Point.
Commercial brandy	69	92
“ whiskey	72	96
“ gin	72	101
Kerosene (average quality).....	73	104
Petroleum (high test).....	110-120	140-160

Proportions of Fuel Mixtures.—In the free air the only point to be considered is the required temperature for flashing or firing, since atmospheric circulation will always supply the full amount of oxygen for combustion. In a gas engine cylinder, closed from the outer air, it is necessary to know how much air must be admitted. The most efficient proportions of air and gas, mixed to give a perfect combustion in a closed cylinder may be considered a matter in many respects relative to the kind of gas employed—some gases require more, some less, for the best effects from combustion. In general, however, the data on coal gas may be taken as typical for most fuels available in ordinary gas-engine service. With this fuel the figures for efficiency range between 6 to 1 and 11 to 1 for air and gas, respectively. That is to say, with a mixture of about 5 to 1 or of about 12 to 1, for example, the effective pressure due to combustion—if combustion is possible at all—shows a marked falling off, which continues thereafter as the proportion of air in the mixture is diminished or increased. Between the efficient extremes, however, it has been found that, although the actual indicated explosion pressure decreases in ratio with the increased percentage of air in the mixture, the efficiency steadily increases until the point of 11 to 1 is approximated. This fact is explained by as-

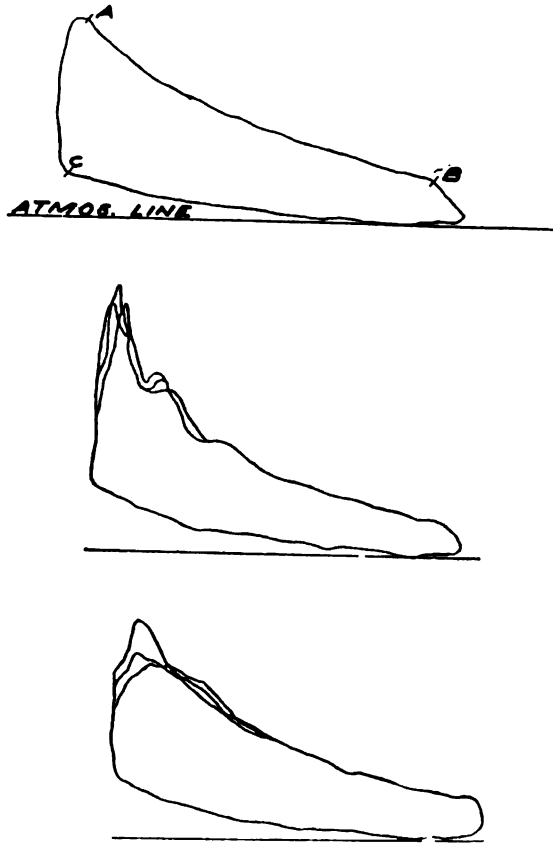

FIG. 300.—Gas Engine Indicator Cards. The first diagram is an average good card, showing, however, some slight fluctuations in the lines. The explosion line is from C to A; the expansion, from A to B; the exhaust at B. The suction stroke generally approximates the atmospheric line, from which the curve of compression rises to C. The second diagram is from an engine running under half load; the third from one at full load. Both exhibit the variations in the expansion curve, usually attributed to consecutive explosions. The second and third cards are composites of three successive strokes each.

suming that, in increasing the proportion of air in the mixture, the temperature per unit of gas is raised, although the temperature per unit of the mixture of gas and air is lowered. Since, therefore, the gas itself is the sole agent of efficiency—the condition necessary to explosion being all that is furnished by the admixture of air—the increase in the proportion of air in the charge, up to the specified limit, increases the total efficiency, even though lowering the pressure of the explosion.

Some Results of Imperfect Compression.—On account of another consideration, the proper proportion of air and gas for a given case is important, and, when combined with an adequately adjusted compression, is a factor in promoting efficiency. This refers to the fact that, as shown by numerous indicator diagrams, the firing of the whole mass of gas, contained in cylinder, is not always an instantaneous process—some diagrams showing several consecutive explosions, of decreasing effect to be sure, which tend to make the action of the engine fluctuating and uncertain. This effect has been ascribed to a “defective mixture,” but such could not be the sole cause of all the phenomena, since alone, it would rather occasion an explosion of insufficient pressure, if any explosion at all. The truth is that the mixture, in such cases, is defective from the fact that it does not contain sufficient oxygen to the total bulk to produce perfect ignition, in view of the presence of burned out gases in the clearance. As described by some writers on the subject, these residua of previous combustions develop the tendency to *stratify* the mixture, and, unless the air is in proper preponderance to the percentage of pure fuel gas, or, unless the compression ratio is adjusted to produce adequate blending of the inflammable elements, the result will be several explosions, as the successive layers of gas, separated by unburnable products, become ignited. Among other elements that combine to promote the conditions just specified are certain chemical changes, giving rise to gases of high fire temperatures, or causing shrinkage in the proportion of good fuel mixture in the cylinder. Defective or inferior firing devices are also liable to produce slow and irregular combustion.

As many of the conditions of gas engine operation seem to be somewhat uncertain, in the minds of even prominent authorities, it is only fair that we quote several opinions contrary to those a!

ready stated. A well-known designer and manufacturer of vehicle motors, in a letter to the author, denies the theory of "stratification" of the charge with the residua of previous combustions, asserting that the indicator diagram phenomena, usually attributed to several successive explosions, are due rather "to irregularities of the indicator or to vibrations of the gas in the indicator piping, and not to variations in the rate of combustion." He also deprecates the importance given by some writers to the efficiency of a high compression in producing a better blending of the fuel mixture, attributing the good results, apparently thus obtained, to the time occupied in making the compression, which also serves to perfect the mixture, and also to the fact that compression produces heat, thus also promoting readiness of ignition.

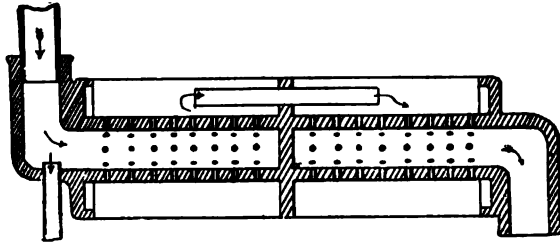

FIG. 301.—The Benz Exhaust Muffler. The arrows indicate the course of the expanding exhaust products. Entering at the left, they pass through the perforations in the tube; thence through the smaller tube in the larger chamber; again through the perforations in the right-hand section of the tube, and to atmosphere. The breaking-up of the gas in expansion silences the noise of its exhaust to atmosphere.

Defective Combustion: Advantages of Scavenging.—In addition to the irregularities of action, just enumerated, the presence of burned out gases in the clearance operates effectually to reduce both the pressure and temperature of combustion by several per cent. This fact is demonstrated by comparing the figures for explosion pressures and temperatures of scavenging and non-scavenging gas engines of the same proportions. For although, as we have already seen, the figures for compression pressure and temperature are higher for non-scavenging, or ordinary, gas engines than for the other variety, due, as has been asserted, to the recompression of burned products in the one engine, or else to the use of cooling air currents to expel these in the other, the case is directly reversed at the moment of ex-

plosion. From this fact, as may be readily understood, a scavenging engine should be the more effective, as securing the better ignition of the charge and as permitting the loss of less heat in proportion to the total of units generated. The principle has been adopted successfully with several well-known types of stationary gas engine, although, so far as the writer can ascertain, few, if any, attempts have been made to adapt it to use in motor vehicles.

Its inefficiency in this connection would arise from several conditions, prominent among which would be the added complication necessary to the end of eliminating the burned gases under high speed conditions and the uncertainty involved, with the constantly recurring danger of thus lowering, rather than raising, the value of the charge by irregular variation of the mixture. Also the rate of jacket water consumption would always be greater owing to higher temperatures. The force of these remarks may be understood when we consider that the most usual and practical method of scavenging a gas engine cylinder is to drive out the burned residua by admitting a current of fresh air into the clearance. The method of extending the sweep of the piston clear to the rear end of the combustion chamber, so as to expel the contents mechanically, was used with success on the Atkinson variable stroke gas engine, now no longer manufactured, also on the Diesel engine, but it is the least economical procedure, owing principally to the necessity of using a plane surface cylinder head instead of one of segmental profile, and some such complicated mechanical devices, as were used in the Atkinson cycle. The fresh air method requires only that the crank case be used as a pump chamber for the air.

Data on Scavenging Cylinder.—In order to show how that the burned out gases in the clearance operate to lower the explosion efficiency, we can do no better than quote again from the "Power Quarterly" treatise already mentioned. Here the following occurs: "The difference due to the presence of burned gases is considerable. A mixture of 9 to 1, with no burned gases present, gives a rise of about 2,373 degrees; the same mixture, compressed with the burned gases of a previous explosion in a clearance of 41 2-3 per cent. of the cylinder volume gives a rise of only about 1,843 degrees.

“The resulting temperatures of explosion in the two cases do not differ so greatly as the rise in temperature, because the scavenging engine starts from a lower initial temperature and the rise during compression is not so great. For example, assume an engine with 3.4 compression ratio, running scavenging with an initial pressure of 13.2 pounds and an initial temperature of 580°; and suppose a similar engine running plain, with 13.2 pounds initial pressure and 600° initial temperature. The results are compared below on the basis of a 9 to 1 mixture:

	Ordinary.	Scavenging.
Initial temperature	600	580
Compression temperature	921	858
Rise in temperature by explosion.....	1,843	2,373
Temperature of explosion.....	2,764	3,231

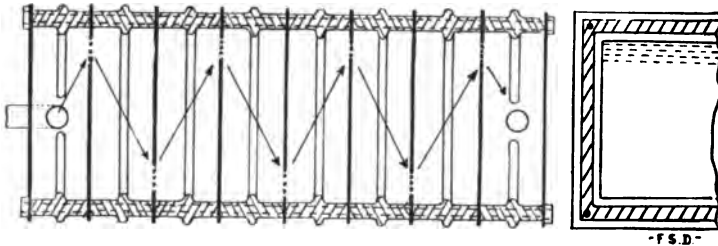

FIG. 302.—Section and End View of an Efficient American Muffler. The muffler consists of a series of chambers formed by screens, perforated alternately at top and base, so that the expanding exhaust gas follows the course indicated by the arrows; their passage through the perforated sections serving to break it up and silence the noise due to its pressure.

“In this comparison the difference in the rise of temperature is nearly 29 per cent., while the difference between the explosion temperatures of the two engines is only scant 17 per cent. A better comparison may be had by considering the pressures; these figure out as follows:

	Ordinary.	Scavenging.
Initial pressure	13.2	13.2
Compression pressure	68.86	66.4
Explosion pressure	206.65	250.0

“Thus, the scavenging engine shows a maximum temperature about 17 per cent. higher than the other engine, while its maximum pressure is a trifle over 21 per cent. greater. . . . While excessive explosion pressures are not desirable, it is clearly

advantageous, within practical limits, to increase the difference between the maximum forward pressure and that of compression, because it increases the area of the indicator diagram. And as this result is obtained by scavenging, without consuming any more gas, the superiority of a scavenging engine is obvious."

Exhaust Losses in Heat and Power.—Having followed the operation of a gas engine through its entire cycle, discussing the several conditions of efficiency and the causes of lost power, it is proper to touch briefly on another notable cause of waste, which is frequently mentioned in gas engine treatises. This refers to the expulsion of a considerable proportion of heat and power units through the exhaust. According to average experience, there seems to be no practical method of utilizing any of

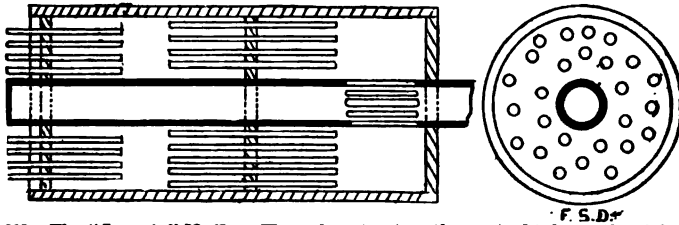

FIG. 308.—The "Loomis" Muffler. The exhaust enters the central tube at the right-hand end, passing out through slits shown in its side to the main chamber, where it is passed through a number of lengths of tubing. Leaving these it emerges to atmosphere through another set of tube lengths.

the elements thus thrown to waste, unless we resort to contrivances for "compounding" the cylinders, somewhat after the plan of the double and triple expansion steam engines. The principal reason why this loss may not be avoided is that, as the gas, after explosion may not be expanded so as to stand at atmospheric pressure on the completion of the power stroke—the expansion line then standing generally about or above the figure indicated for compression pressure—it is necessary to open the exhaust before the completion of the stroke. This opening point is generally about $\frac{1}{3}$ stroke. Were the engine otherwise geared, and the piston allowed to receive the pressure of the expanding gas through its full stroke, the gas retained until that time would not exhaust fast enough to avoid buffing the piston on its return sweep, since through an appreciable distance the continued expansion would balance the rate of escape through the exhaust valve.

The effect of this would be to check the speed and power of the engine, with the result of absorbing about as much power as would on the other plan be turned to waste.

The Variation of the Curve of Expansion.—The reason given for the variation from the compression line of the curve of expansion following explosion is that the combustion is not only not instantaneous, but continues during the greater portion of the stroke, thus constantly keeping up the temperature and pressure, which would, otherwise, tend to fall regularly from maximum to atmosphere. Thus the expansion line does not meet

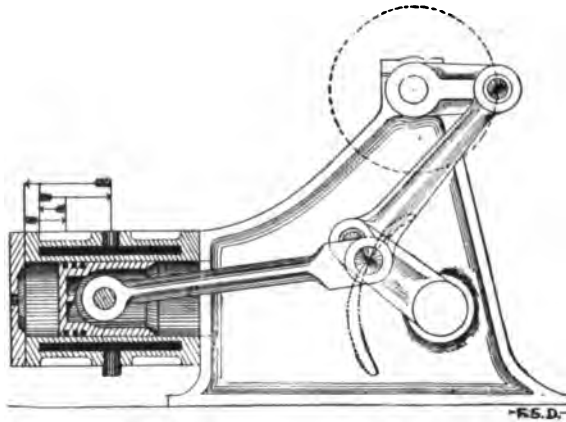

FIG. 304.—Section of the Atkinson Cycle Gas Engine, showing the varying lengths of the strokes—from the top, exhaust, expansion, compression, suction; also, the figure-of-8 path described by the toggle-jointed crank connections, and the path of the crank.

the compression line at the end point of the stroke, as should be the case under theoretically perfect conditions, with the result that the exhaust valve must be opened before the completion of the stroke, as above stated. An interesting approximation of this standard is found in the Atkinson cycle scavenging engine, which, on account of certain mechanical peculiarities of construction, is able to expand the charge from 185 pounds at explosion to 10 pounds, gauge, at the completion of the power stroke. In this machine the piston rod is connected to a double toggle joint, as indicated in the accompanying diagram, with the result that the piston makes its four strokes in a single revolution of the fly-

wheel, giving a suction stroke through about one-half the sweep length, a return compression stroke to a point about 5-6 the sweep, an impulse stroke from that point clear forward, and an exhausting stroke from end to end of the cylinder. As claimed in a published description, the working effects are that: "The clearance space beyond the terminal exhaust position of the piston is so small that, practically, the products of combustion are entirely swept out of the cylinder during the exhaust stroke, so that each incoming charge has the full explosive strength due to the mixture used.

"It is also possible to expand the exploded charge to such a volume that the terminal pressure will be reduced to the lowest possible point, and that, owing to the purity of the charge, the

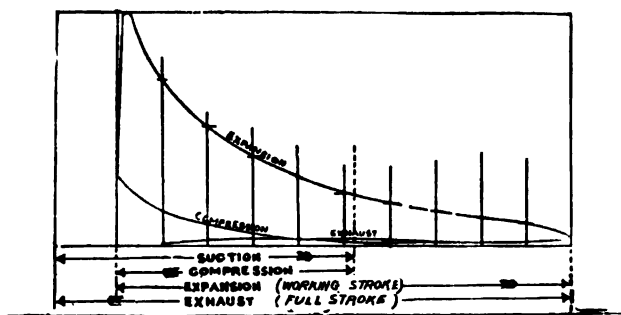

FIG. 305.—Indicator Card for the Atkinson Variable Stroke Four-Part "Two-Cycle" Gas Engine.

greatest possible pressure will be attained at the commencement of the expansion."

The accompanying indicator card of an Atkinson engine, of 18 I. H. P., working at 130 revolutions per minute, with a mean pressure of 49 pounds, shows the excellent results achieved by thus varying the length of the several strokes. But such a procedure is impossible in the ordinary four-cycle engine, which finds the only available method of securing approximately complete combustion in varying the proportions of the fuel mixture, and by scavenging the cylinder.

The Ratio of Expansion.—As may be readily understood, the practice of opening the exhaust valve at about $\frac{1}{4}$ power stroke gives one reason why that the expansion ratio differs so greatly

from the compression ratio, with which, theoretically, it should be identical. On the Atkinson cycle this correspondence is practically realized, but with engines constructed on the Otto cycle it represents the quotient found by dividing the sum of the total cylinder content (clearance plus piston sweep) and that portion of the stroke and clearance content, left behind the piston at the moment the exhaust opens, by the cubic content of the clearance. This may be expressed by the following formula:

$$E_r = \frac{C + \frac{n}{c}}{B} = \frac{\text{Volume of Expansion}}{\text{Volume of Clearance}}$$

in which E_r is the ratio of expansion.

C " the total cylinder content.

B " the combustion chamber or clearance content.

n " the numerator expressing the portion of the cylinder content left behind the piston at the opening of the exhaust.

Data on Losses by the Exhaust.—In the process of exhausting, the burned gases issue from the cylinder; first place, largely under their own force of expansion, which continues down to atmospheric pressure; secondly, after the change of stroke, under the force of the returning piston. The pressures and temperatures thus voided are, of course, in proportion, first place, to the figures realized in explosion, and, secondly, to the expansion ratio of the particular cylinder under test. Both are found to decrease with increasing ratios. Thus, under ordinary conditions with engines driven by illuminating gas, an explosion temperature of 3,000 and an explosion pressure of 250 for a ratio of 3 give an exhaust temperature of 2,158 and an exhaust pressure of 59.9; for a ratio of 3.5 they give 2,060 and 49.0; for a ratio of 4 they give 1,979 and 41.2; for a ratio of 5 they give 1,851 and 30.8; for a ratio of 6 they give 1,752 and 24.3.

In order to fully describe the situations involved, we can do no better than to quote again from the treatise already referred to in several connections. Here we have it that:

"The compression ratio ranges in present practice from 3 to 4; with the former ratio the exhaust pressure is never less than 35.7 pounds, and with the latter 24.7 pounds, absolute, and it is usually

around 45 pounds for one and 30 for the other, as the explosion pressure is generally 180 to 200. So that there is a waste usually of 15 to 30 pounds available pressure at the end of the power stroke. And, as the explosion temperature is almost always around 2,500 and is frequently near 3,000, the temperature of the exhaust is generally from 1,600 to 1,900—say 1,760 average, or 1,300° by thermometer scale. This means that if the outdoor temperature is 70°, a difference of 1,230° is thrown away. And as the specific heat of the products of combustion averages .26, every pound of exhaust gas emitted at 1,300° F. into an atmosphere of 70° means throwing away $1,230 \times .26 = 319.8$ heat units, or $319.8 \times 778 = 248,804$ foot pounds of energy.

“Suppose we assume an expansion ratio of 5.8, in order to get a great expansion, and a compression ratio of 6. Then assume an ordinary engine, because the effect of explosion is not so great and a mixture of 12 volumes of air to 1 of gas, because that is the weakest reliable mixture. Starting with the highest practical initial temperature, 660°, and the lowest practical initial pressure, 13, the following results are obtained:

	Pressure.	Temperature.
Initial	13	660
Compression	146	1,236
Rise	—	1,755
Explosion	353	2,991
Exhaust	35.9	1,765

On Compounding Gas Engine Cylinders.—The enormous waste, as indicated by the figures given above, which show that over 7.5 horse-power per pound of fuel gas goes through the exhaust valves, is a good argument for seeking some device to utilize at least a part of this lost energy. The Atkinson cycle engine, as described above, seems to fill many of the requirements in this respect for stationary engines, but for motor carriage purposes compounding seems to be the most available system at present under consideration. The subject has been discussed at considerable length in magazines devoted to motor carriage interests, and an engine embodying the proposed requirements has been constructed by Messrs. Crossley and Atkinson in England. This motor, shown in an accompanying illustration, consists briefly of three cylinders—two primary, or high pressure, be-

tween which is a secondary, or low pressure, cylinder. The volume of the low pressure cylinder is about twice that of either of the high pressure cylinders, thus allowing the exhaust gas to expand very nearly to atmospheric pressure, when fed into it from either of the others. The crank shaft is so arranged that, while the two low pressure pistons are at the dead end of the in-stroke—the one, of compression, the other, of exhaust, for example—the low pressure piston is at the dead end of its out-stroke, or power-stroke. Thus the exhaust gas is fed to the low pres-

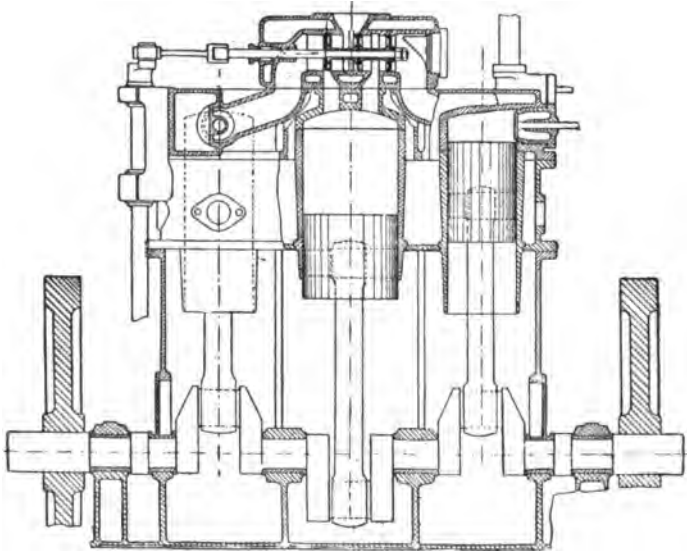

FIG. 306.—Crossley Three-Cylinder Compound Gas Engine. The two end cylinders are high pressure; the central one, low pressure. The exhaust from the two high-pressure cylinders is admitted, alternately, to the low-pressure cylinder by the piston valve, operated by the crank and rotating shaft shown at the left. The exhaust from the low-pressure cylinder passes upward through the port at its top.

ure cylinder from both high pressure cylinders alternately, and it performs a power-stroke once in each revolution of the fly-wheel, always alternately to either of the others. As may be seen from examination of the drawing, connection between the high pressure and low pressure cylinders is had by means of a triple piston valve moved longitudinally on a secondary shaft and so arranged that pure atmospheric air may be admitted to the centre cylinder, when either of the others misses fire. Compound

gas engines, made by other engineers, have the cranks geared at a little over one-third of the total revolution, instead of at 180° , as in the one shown. It has also been proposed to make the volume of the low pressure cylinder at least three times that of either of the others, but this seems excessive from the fact that the expanding gas fed into it would expand to a point below atmosphere. The editor of the "Horseless Age" gives a formula demonstrating this, as follows:

$$P^1 = P \left(\frac{V}{V^1} \right)^y$$

in which P is the initial low-pressure pressure, V , the initial low-pressure volume, P^1 , the final pressure, at the end of the low-pressure power-stroke, V^1 , the final volume at the same point, and y , the ratio of the specific heat of the gas at constant pressure to the specific heat at constant volume, which is about 1.5 for gasoline exhaust. Then, taking as the value of P the average of 55 pounds, absolute, with 1-3 as the value of the fraction because the ratio of the cylinders is 1 to 3, we have

$$P^1 = 55 \left(\frac{1}{3} \right)^{1.5} = 10.6 \text{ absolute.}$$

The result shows a pressure of about four pounds below atmosphere, which, although indicating a very complete utilization of exhaust gas, involves a cut-off of the efficient power before the completion of the stroke, unless a compound gas engine be operated with some kind of vacuum-producing condenser, such as is so important an item with triple and quadruple expansion steam engines. How such an adjunct to a gas engine would operate, and what would be its construction, we need not pause to inquire here.

The Advantages from Compounding.—In addition to economy in heat efficiency, which is the primary object of compounding a gas engine, two other important ends are achieved. In the first place, the muffler, or exhaust silencer, may be dispensed with; since, as in the compound steam engine the highly expanded exhaust products issue to the air without noise. This is a decided advantage; for, since the principle of a muffler involves im-

posing obstacles, so as to break up the full force of the gas as it expands, it furnishes an undesirable back pressure that absorbs a goodly part of the output power. In accompanying diagrams several types of efficient muffler have been shown, but as the question of proportions is in place here a few facts will be given. As indicated by Roberts, the formula for the cubic content of a muffler best calculated to save power gives 3.5 times the square of the cylinder diameter in inches multiplied by the length of the piston stroke in inches, or

$$M = 3.5 D^2 L.$$

A French authority states that an engine of 8 I. H. P., running without muffler, gave 6.1 B. H. P. at 967 revolutions per minute, but, with muffler, gave the same efficiency only on 1,012 revolutions. He also found for a 2.25 I. H. P. engine an efficient output of 2.16 at 2,015 revolutions without muffler, and, of 1.91 at 2,057 revolutions with muffler, claiming a loss of 20 kilogram-meters, or 145 foot pounds per second.

In the second place, a compound gas engine of the Crossley-Atkinson type presents the advantage of affording a steady drive, as in a steam engine, thus obviating the necessity of leaving the fly-wheel to "store up" power sufficient for three idle strokes. It is probable that, as motor carriage construction approaches greater perfection, the subject of compounding will come increasingly to the front on account of these and other advantages.



FIG. 306a.—A Typical Carriage Motor and its adjuncts: battery box and fuel tank; carburetor; cylinder on enclosed crank case; muffler; induction coil in gutta percha case; jacket water cooling radiator.

CHAPTER TWENTY-SEVEN.

GAS ENGINE EFFICIENCY, AND ITS OPERATIVE CONDITIONS.

Conditions of Operation: Maximum Efficiency.—Having now set forth and discussed several of the more important occasions of lost efficiency in gas engines, together with some of the methods employed to neutralize waste, it is proper to consider briefly the conditions of efficiency and their computation. As may be readily understood from the facts stated, no gas engine can realize the full power, which, theoretically, it should produce. Even under the most favorable conditions, with the observance of all rules and the use of all means, mechanical and otherwise, to conserve energy, it must fall below the figures reached by calculation. Thus, as given by several writers on gas engines, there are at least four different equivalents of the word, efficiency: Maximum theoretical efficiency, actual heat efficiency, mean efficiency and mechanical efficiency.

The *maximum theoretical efficiency* assumes perfect conditions and a perfect indicator card diagram, showing an output of power equal to the figures realized by the highest explosion pressure, with instantaneous and complete combustion and effective adiabatic expansion to atmosphere during the power-stroke. It is estimated, therefore, as the difference between the explosion temperature, absolute, and the initial temperature, absolute—which is to say the number of degrees rise from initial to explosion—divided by the explosion pressure. Thus it may be expressed as

$$\frac{\text{Rise in degrees}}{\text{Explosion temperature}} = \frac{T'' - T'}{T'} = \text{Efficiency.}$$

This formula holds good because, on the theory of the perfect gas engine, the gas, after explosion, should be expanded to atmosphere, with the utilization of every unit of heat, or the return to the initial temperature. The efficient figure, therefore, is the rise from initial to explosion.

Thus, assuming an initial temperature of 660°, absolute, and an

explosion temperature of 3,000°, absolute, we have, by the formula,

$$\frac{2340}{3000} = .78$$

as the percentage of theoretical efficiency under such high temperatures.

Another formula calculates the maximum theoretical efficiency as the quotient of the initial temperature and the rise in degrees absolute to the explosion point. Thus:

$$\frac{660}{2340} = .282 \text{ and } 1 - .282 = .718 \text{ per cent.}$$

In either case, however, the figures would be modified by the fact that the specific heat of all gases differs between the conditions of constant volume and constant pressure. Thus the specific heat at constant volume for a 12 to 1 mixture of air and coal gas is .1803, and for constant pressure, .2526. Their ratio is

$$\frac{.2526}{.1803} = 1.4$$

Consequently, to obtain the most exact figures, we must multiply the former quotient by 1.4 and subtract from 1, as before, to discover the percentage. Thus, we have the formula:

$$1 - 1.4 \frac{660}{2340} = 1 - (1.4 \times .282 = .3948) = .6052$$

as the percentage.

The Actual Heat Efficiency.—Owing to various causes, partly mechanical, partly physical, as already discussed, even this percentage is impossible in an ordinary four-cycle engine; since contrary to the theory of the above formula, the exploded gas is not expanded to initial pressure and temperature, but only to a much higher point at exhaust. Instead, therefore, of the above formula, we divide the exhaust temperature, Fahrenheit, by the figure for internal temperature rise, Fahrenheit, multiply by 1.4 and subtract product from unity. Thus, taking 1,500 as a fair average temperature at exhaust, we have:

$$1 - 1.4 \frac{1500 - 461}{2340 - 461} = 1 - (1.4 \frac{1039}{1879} \text{ or } .552 = .7728) = .227$$

as the percentage of efficient power to be realized from an average gas engine under most favorable conditions. The maximum theoretical efficiency, therefore, is impossible in practice, even under ideal conditions; since it assumes that the expansion line of the indicator diagram is perfectly *adiabatic*, which is to say, indicating an expansion without loss or gain of heat units, to atmosphere. The figures are valuable, most largely, as indicating the necessary limitations of gas engine operation and construction. Some of the best gas engines, however, give an indicated power-output of 30 per cent. and over, according to claims

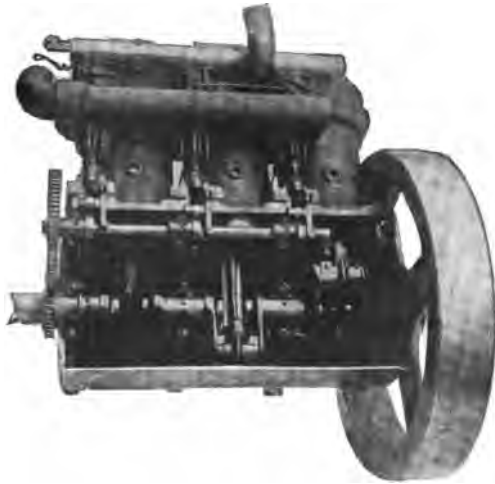

FIG 307.—The Duryea Three-Cylinder Gasoline Vehicle Engine, with half the crank case sheathing removed, showing cranks, crank shaft, cam shaft, and working parts. The three cylinders have common supply and exhaust tubes; the charge is controlled by a single throttling link, shown at the top, and the igniting circuit has three bridges for the three cylinders

—some assert slightly higher figures—but, even with this low average the gas engine is superior to the steam engine.

Testing by the Pyrometer.—The formulæ just given illustrate one very essential point in gas-engine operation, which is that, given the temperature, absolute, at the moment of exhaust, the efficiency of the working cycle may be approximately estimated; always, of course, allowing due value to the heat losses through the cylinder walls, and otherwise, as above discussed. The heat

of exhaust averages between 1,500° and 1,900°, absolute, according to the compression ratio, which determines the range of temperature rise at explosion; according to the expansion ratio, which determines the range of effective heat and power, and, consequently, according to the temperature of explosion. Of course, such high temperatures may not be determined by an ordinary thermometer; for, since the vaporizing point of mercury is at 675° Fahrenheit, no rise beyond that could be adequately measured. Accordingly, the device used is that known as a pyrometer, one form of which consists of an electric circuit containing a source of current, a galvanometer and an iron tube, enclosing a contact of an electrode of platinum and an electrode of iridium. When it is desired to determine the temperature of a given point or body the iron tube is placed thereat, and the heat, causing the enclosed platinum and iridium to expand, increases the electrical pressure of the contact. The principle involved is that by increasing the pressure in this manner at any part of the circuit increases the total strength of the conducted current. Thus, the relative increase in this respect may be measured in the galvanometer, whose readings, within thermometric range, have already been determined for several known temperatures, enabling the discovery of the ratio on which the current conductivity of the circuit increases with temperature rise per degree. There are several other varieties of pyrometer, based on as many different physical and mechanical properties of matter, but the one described—it is known as Chatelier's pyrometer after its inventor—seems to be the most philosophic and reliable.

Heat Efficiency: Theoretical and Practical.—From the facts thus far set forth it may be understood that the *actual heat efficiency*, which represents “the ratio of heat turned into work to the total heat received by the engine,” furnishes the percentage on which is based the calculations for “indicated horse power” (I. H. P.). But, on account of the unavoidable waste of heat, in the first place, and of power, in the second place, in producing and maintaining the conditions of operation within the cylinder—in keeping the temperature within operative limits, and in overcoming the physical inertia of the moving parts—the indicated horse power is always much greater than the delivered horse

power (D. H. P.) or brake horse power (B. H. P.), when both are stated in terms of heat units consumed. Owing to the physical properties of gases and to the conditions of waste, which reduce the expansion line from the theoretical adiabatic to a figure very different, the total efficiency, as we have seen, falls from 72 per cent. to 26 per cent. The greatest possible available percentage, however, due to the nearest practicable approach to ideal conditions, would represent a mean between these. Consequently, we may derive the *mean theoretical efficiency*, as the ratio between the actual and the maximum figures, which gives us:

$$\frac{\text{Indicator reading}}{\text{Theoretical efficiency}} = \frac{26}{72} = .361,$$

as the figure representing the greatest possible utilization of heat in the operation of a gas cylinder.

Mechanical Efficiency in Heat Units—Similarly also, the fourth head of efficiency, the *mechanical efficiency*, of a gas engine, represents the ratio between the delivered horse power, as found by Prony brake or dynamometer, and the indicated horse power, the difference in practice being the power lost by general internal friction of the engine. Thus, if the indicated horse power is 10 and the delivered horse power is 8, the ratio is found as follows:

$$\frac{\text{D. H. P.}}{\text{I. H. P.}} = \frac{8}{10} = .80.$$

To state this in terms of heat expended, we find that one horse power is 33,000 foot-pounds per minute, and that 778 foot-pounds equals one thermal unit, which equation expresses the *mechanical equivalent of heat*. Whence, one horse power per minute equals 42.42 thermal units, which is, by the hour 2,545 thermal units. Then 10 H. P. equals 25,450 thermal units and 8 H. P. equals 20,360 thermal units. Whence we have:

$$\frac{20360}{25450} = .80.$$

If, however, 10 H. P., or 25,450 B. T. U. per hour be assumed equivalent to the I. H. P. of a given engine, which is, as we have seen, 26 per cent. of the total fuel efficiency supplied to the engine, we have it that the total theoretical value of the fuel should be 97,884.61 B. T. U., or 38.46 H. P. According to a noted authority, the average of a number of tests of gas engines is as follows :

To the jacket water	52 per cent.
To loss in the exhaust	16 " "
To loss in radiator, etc.	15 " "
To useful work (D. H. P.)	17 " "



FIG. 306.—Four-Cylinder, 10 H. P. "Buffalo" Gasoline Engine for Motor Vehicle Use. The gearing of this motor renders it non-vibrating, as guaranteed, while, by the "shifting-spark" system of governing, the speed may be varied from 100 to 1,500 R. P. M. without changing the motion of the valves. This is an exceedingly flexible system of governing. The cylinder head is water-jacketed; the firing stroke in the four cylinders follows consecutively, thus securing perfect balance; the inlet valves are positively operated, thus enabling a wide range in adjusting fuel charge ratios. On account of the four-cylinder positive igniters, the engine is very easy to start.

This shows a total of 83 per cent. lost for efficient mechanical work, or useful, at best, only for maintaining necessary interior conditions. Accepting these figures as fairly typical, we find for 10 I. H. P., or 26 per cent., a total of 97,884.61 thermal units, or 38.46 H. P. by the hour, theoretically fed to the cylinder in shape

of fuel mixture. Giving the other quantities their proper thermal and mechanical equivalents, we have :

52%	=50899.9972	B. T. U. =	19.9992	H. P.
16%	=15661.5376	B. T. U. =	6.1536	H. P.
15%	=14682.6915	B. T. U. =	5.7890	H. P.
17%	=16640.3837	B. T. U. =	6.5382	H. P.
<hr style="width: 50%; margin: 0 auto;"/>				
100	97884.6100		38.4600.	

This example, drawn from actual averages, represents only 6½ B. H. P. on 10 I. H. P., but in general practice the figures are usually given as about 8 to 10.

Another authority, as quoted by several writers, finds the following results from a series of experiments with a 125 H. P. gas engine: At full load 26 per cent. of the heat energy becomes converted into mechanical energy, 44 per cent. lost through the exhaust and by radiation and 30 per cent. absorbed by the jacket water. At three-quarter load, the figures become 25, 38 and 37 per cent. respectively; at one-quarter load, 18, 28, 54, and, when running free, 10, 32 and 58 per cent. These figures show that the percentage of loss through the exhaust increases as the jacket loss decreases. Other recorded tests show similar figures.

To discover the calorific value of a gas by the cubic foot, or by any other unit of cubic or weight measure, the following formula has been laid down for determination by the cubic amount consumed in raising the temperature of water by the degree :

$$H = \frac{W T}{G},$$

in which H is the calorific value ;

W “ “ quantity of water by volume ;

T “ “ difference in temperature of the water supplied and the water heated ;

G “ “ quantity of gas, in cubic feet, required to raise the water to the given temperature.

Supposing that in a given case, W is equal to 1 liter (.22 gallon) ; T is equal to 18, or the difference between 27°, the acquired temperature, and 9°, the initial temperature of the water ; and G,

as measured by a gas meter, or other suitable method, equals .190 cubic foot. Then:

$$H = \frac{1 \times 18}{.190} = 94.73 \text{ thermal units.}$$

as the gross calorific value per cubic foot of the particular mixture of gas and air used for the experiment. The *net value* is usually estimated at about 15 per cent. of the gross for most fuel gases, as found by the average of calorimeter tests. Whence, since 15 per cent. of 94.73 is about 14.21, the net value here is 80.52 calories, which indicates the percentage of heat units actually efficient in raising the temperature of the water.

Calorific Value of Fuels.—As given by reliable authorities, the calorific value of several common hydrocarbon fuels, as expressed in thermal units, is as follows:

	Per Pound.	Per Cubic Foot.
Marsh gas (C H ⁴).....	23,594	1,051
Benzine (C ⁶ H ⁶).....	18,448	————
Benzine (C ⁶ H ⁸).....	18,448	————
Acetylene (C ² H ²).....	21,492	868
Ethylene (C ² H ⁴).....	21,430	1,677
Natural gas	————	480 to 590
Illuminating coal gas.....	————	620 to 950
Water gas (average).....	————	710

Having ascertained these facts, we are prepared to determine the thermal efficiency of the engine, or the ratio of heat utilized, as compared with the total heat equivalent of the fuel absorbed. For this purpose the following formula is given by Goldingham:

$$E = \frac{42.63 \times 60}{C X},$$

in which C expresses the fuel consumption per B. H. P. per hour in pounds, and X the calorific value of the fuel per pound in thermal units.

Although the constant 42.63 should vary somewhat according to the figures for heat and power equivalents as used by other authorities we may use this formula for approximate figures. By the table of percentages given above, we find that for each B. H.

P., or 2545 B. T. U., 5.88 H. P., or 14964.60 B. T. U., are expended. Since gasoline contains 21,900 B. T. U. per pound, we find that this average figure gives us 0.683 pounds fuel consumption per B. H. P. per hour. Then, by the formula, we have:

$$E = \frac{42.63 \times 60}{.683 \times 21900} = \frac{2557.80}{15157.7} = 0.1687.$$

as the approximate thermal efficiency percentage. This figure agrees with the average percentage for B. H. P., given above, and, as may be seen, can be found by knowing simply the rate of fuel consumption and the B. T. U.'s per pound.

Determining Calorific Values.—Knowing the specific heat of a given gas at constant volume, the calorific value in thermal units may be discovered as follows, in order to estimate the thermal efficiency of an engine:

$$H = C (T - t).$$

In this formula H is the calorific value in thermal units; C, the specific heat at constant volume; T, the temperature of explosion, and t, the initial temperature. The specific heat for a 9 to 1 mixture of air and coal gas being 0.1846; a typical explosion temperature 2,764°, absolute, and an average compression temperature, 921°, we have 340.21 thermal units per pound of the initial charge, which is equivalent to 264683.38 foot-pounds, and

$$\frac{264,683.38}{33,000} = 8.02 \text{ H. P.}$$

Determining the Explosion Pressure.—The maximum, or explosion, pressure of a gas-engine is equal to the ratio between the compression and maximum temperatures multiplied by the compression pressure. Thus:

$$\frac{Ct}{Et} \times Cp = Ep.$$

Substituting the values given above for a given engine, we have

$$\left(\frac{2764}{921} = 3 \right) \times 68.86 = 206.58 \text{ pounds,}$$

which, as may be seen, is the same as formerly given in Chapter XXIV. (page 348):

$$P^* = \frac{T^* P^*}{T^*}$$

In order to estimate the mechanical efficiency of a given engine we must, as shown above, know the delivered horse power. While there are numerous ways of calculating this, the simplest and readiest formula is as follows:

$$\frac{D^2 L R}{18,000} = \text{D. H. P.}$$

which means that the square of the piston *diameter* in inches is to be multiplied by the *length* of the stroke in inches and the number of *revolutions* per minute of the fly-wheel, and the product divided by 18,000. This denominator is given by Roberts for a four-cycle gasoline engine. For ordinary four-cycle gas-engines the figure is 19,000. For two-cycle engines operated by gasoline the denominator is given as 13,500; for other types, as 14,000.

To apply this formula we will take a highly efficient three cylinder gasoline vehicle motor with proportions, as follows: The piston diameter is 4.5 inches; the stroke is 4.5 inches; the number of revolutions per minute is 600. Then, substituting, we have:

$$\frac{20.25 \times 4.5 \times 600}{18,000} = \frac{54,675}{18,000} = 3.03 \text{ H. P.}$$

Calculating for the three cylinders we have the formula:

$$\frac{D^2 L R N}{18,000} = \text{H. P.}$$

in which N is the number of cylinders. Whence:

$$\frac{54,675 \times 3}{18,000} = 9.11 \text{ H. P.}$$

This figure is a good average for the formula, although as the writer is assured by the manufacturer of the engine, $10\frac{1}{2}$ D. H. P. has been obtained by actual brake tests.

Similarly, on the basis of these figures, we may calculate the mechanical efficiency per cubic inch of piston displacement, or fuel capacity, as follows :

$$\frac{33,000 \times 3.03}{15.904 \times 4.50 \times 300} = \frac{99,990}{21,470.4} = 4,658.$$

In this equation, 15.904 represents the area in inches of a 4.5 inch piston; 4.50 represents the length of the stroke; 300 the number of explosions per minute. The numerator, representing the figure for 3.03 H. P. in terms of foot-pounds per minute, is divided by the product of the denominator terms to give the foot-pounds per cubic inch of stroke space. The result is verified by performing the following operation :

$$\frac{15.904 \times 4.50 \times 300 \times 4.65}{33,000} = \frac{100009.1232}{33,000} = 3.03,$$

in which the figure for foot-pounds is multiplied by the cubic content in question and the number of efficient strokes per minute in order to obtain an expression in the numerator, as in the denominator, for foot-pounds per minute. The result of the indicated division is the delivered horse power.

CHAPTER TWENTY-EIGHT.

ON ESTIMATING THE HORSE-POWER OF GAS ENGINES.

Conditions of Efficient Operation.—Following along the lines so far laid down, we find six conditions of high efficiency: 1. The fuel mixture should be carefully proportioned, in order to enable rapid ignition and full utilization of heat. 2. The pressure of compression should be high, in order to enlarge the range of temperature rise at explosion. 3. The wall surface of the clearance, or combustion chamber, should be as small as practicable, in proportion to its required volume, in order to lower the absorption of the heat of combustion and raise the mean wall temperature, facilitating compression. 4. The stroke should be as short as is consistent with good design, in order to reduce the wall surface to which the expanding gas is exposed, with consequent economy of heat and power. 5. The speed of the piston should be high, in order to transform the heat into work with the greatest possible rapidity, also reducing the period of contact between the expanding gases and the cylinder walls. 6. The temperature and rate of circulation of the jacket water should be adjusted, in accordance with careful observation, in order that the temperature of the cylinder may be kept within the required limits, without also absorbing too great a quantity of heat.

The Time Element in Power Estimates.—In the determination of horse-power the *time* element is an important item in all formulæ. This is true because the power to be calculated produces motion and is not simply a static pressure to be measured in terms of pounds weight. In calculating for a gas-engine, also, it is important to remember that the power efficiency increases with the rate of motion, being expressed in terms of revolutions per minute of the fly-wheel or crank shaft. Thus, a given engine running with low gas supply or high load may be able to rotate the fly-wheel only 200 times per minute, while, with full gas supply, or at average load, it can produce as many as 2,000 revolutions per minute. Furthermore, the available power decreases as does the number of revolutions per minute, while, as has al-

ready been indicated, the rate of gas consumption per unit of work is increased. Thus it is important to know, in making estimates for horse-power, whether the engine in question is running free or under load. This fact is generally specified in reports on engine power and operation, and is considered in several formulæ.

Engine Dimensions in Power Estimate.—Next to this, the most important consideration refers to the dimensions of the piston and cylinder and the length of the stroke. For, since these figures indicate the power capacity of the engine, in point of the quantity of fuel consumed, and the power developed by explosion, as acting on the reciprocating parts, they, together with the ascertained rate of motion, are in ratio to a figure equivalent to an average ratio between the operative dimensions of the cylinder—these are given above in Roberts' formula for D. H. P.—and the delivered horse-power. For four-cycle gasoline engines this average denominator is given as 18,000, and the figures resulting from the indicated division are average ones. The formula is further verified in the fact that the piston diameter and length of stroke are in discoverable proportion to the D. H. P. and the number of revolutions of the fly-wheel. So that an engine giving, say, 35 D. H. P. at 600 revolutions per minute, with a fuel whose thermic value is known, must have a certain diameter of piston and length of stroke. These proportions need not be further specified here.

The Mean Effective Pressure.—In making more definite calculations on the power of a gas-engine there are four points to be considered: 1. How great is the mean effective pressure per square inch on the piston during the power stroke? 2. What is the area of the piston? 3. What is the length of the stroke? 4. What is the number of explosions per minute? The ratio between the product of these factors and 33,000 gives the I. H. P. per minute. Thus:

$$\frac{\text{Pressure} \times \text{area} \times \text{stroke} \times \text{E. P. M.}}{33,000} = \text{I. H. P.}$$

To reduce this ratio to a practical formula we take the product of the mean effective pressure of the power stroke; by the area

of the piston *in square inches*; by the length of the stroke in feet; by the number of explosions per minute, and divide by 33,000, which figure expresses the number of foot-pounds per minute per horse-power. Thus:

$$\frac{\text{P A S E}}{33,000} = \text{I. H. P.}$$

Taking the figures for the gasoline engine calculated above, which gave 3.03 D. H. P., we have:

$$\frac{80 \times 15.904 \times .375 \times 300}{33,000} = \frac{141036}{33,000} = 4.27 \text{ I. H. P.}$$

In this operation the figure 80 represents a fair average of mean effective pressure for high-grade gasoline engines under 25 H. P.; 15.904 is the area in square inches of a piston 4.5 inches diameter; .375 is the expression in feet for 4.5 inch stroke, and 300 the number of explosions per minute. The result, 4.27 I. H. P., is a fairly proportionate figure for indicated horse-power of this engine, since, taking 3.03 as 17 per cent., it is equivalent to 22.8 per cent. In order to get anything like exact figures, it is necessary to determine the mean effective pressure, which can be most readily discovered with an indicator tracing, such as has been depicted above. The methods of measuring are either by ruling *ordinates* at right angles to the atmospheric or base line of the diagram and taking the average of their length, or by use of an instrument called the planimeter.

Estimating by the Indicator Diagram.—As may be understood from the term itself, the mean effective pressure is an average expression for the degree of pressure in pounds brought to bear upon the piston of a cylinder during the power stroke. It has been well defined as “the difference between the average gauge pressure shown by the expansion line and that shown by the compression line, minus the back pressure of charging or suction.” As all these operations are depicted on the indicator diagram an average of its proportions will yield the desired result. On the method of calculating by ordinates we proceed as follows: A number of parallel equidistant lines are ruled on the diagram at right angles to the base line, and their lengths measured

between the points where they intersect the compression and the expansion curves. The lengths thus found are added together and the sum divided by the number expressing their number, in order to obtain an expression for the average length. This result is then multiplied by the pressure of explosion as recorded by the indicator tracing. If, then, the average length of the ordinate lines is two inches and the indicated pressure at explosion is 300 pounds, the result would show a mean effective pressure of 600 inch-pounds or 50 foot-pounds.

A simpler method is to find the mean ordinate of the diagram by the following process: Find the centre of the diagram figure

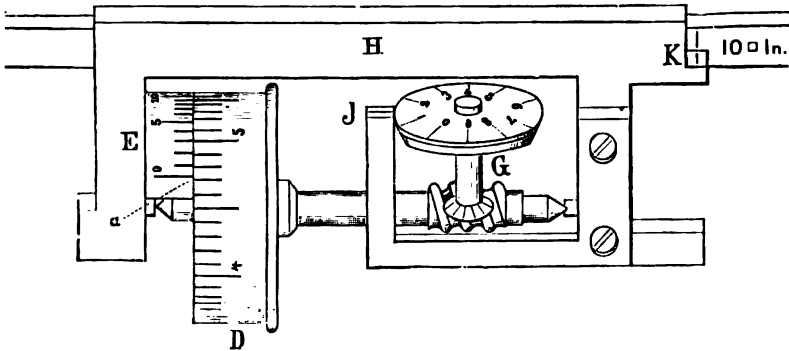

FIG. 309.—Recording Mechanism of a Typical Planimeter. D is the graduated drum, divided into 10 numbered sections, each representing 1 square inch, and 10 intermediate points, each equal to 1-10 square inch. E is the vernier, which is divided into 10 equal parts, each representing 1-100 inch. The wheel, G, records the number of revolutions of the drum, D, each of its graduations being equivalent to 10 square inches, as measured at the post, J. The measurement on the positions shown gives 10 on disc, G; 4 on the roller, D, which is the last number passing zero on the vernier; 7-10 for the smaller graduations on D, as shown by line, a, at zero on the vernier; and 3 on the vernier, as representing the scale point on the vernier opposite to the nearest number on D. The result is, therefore, 14.73 square inches.

on the base line; erect a line perpendicular to the base from that point; draw another line from the base so that it touches the expansion line at about the point of exhaust valve opening, at such an angle that the two parts on either side of the centre line will be equal, measuring from a perpendicular on the explosion line on the one side, and from another touching the "toe" of the tracing on the opposite side. The portion of the centre line thus laid off by intersection is the mean ordinate, which, multiplied by the indicated pressure, gives the M. E. P.

Calculating Diagrams by Planimeter.—A more exact method is by the use of the planimeter, one form of which is shown in an accompanying figure. Briefly, it consists of two arms pivoted together. One of them is arranged to be secured to the board, the other carries a tracing point on the free end and a graduated wheel arranged to indicate square inches and tenths of an inch and a vernier to indicate hundredths. Having secured the instrument to the board in such a manner that the tracer may be set upon the lines of the diagram, the graduated wheel is adjusted so that the point registers zero. Then, moving the tracing point over the entire line of the diagram in the same direction as the hands of a watch, the wheel is made to travel accordingly, and to register the area of the circumscribed space. If, now, the largest figure on the graduated wheel is 2, and the number of graduations thereafter passing zero on the vernier be 6 and the opposite graduation on the vernier be 4, we have the figure 2.64 as the area of the diagram in square inches. This figure should then be divided by the extreme length of the diagram, which may be taken as 3.2 inches, which gives the quotient 0.821875 as the average height of the diagram. This figure multiplied by the scale of the spring, used in the indicator making the diagram, gives the figure for mean effective pressure. If this figure be 40, for example, we have as the result 32.88, as the expression for mean effective pressure. From this it may be understood that the size of the diagram, or the length of the circumscribed line varies according to the strength of the spring geared to the tracing pencil, and, according to the engine pressure bearing upon that spring. Thus a weak spring with a moderate pressure would give a very large diagram, while a strong spring and a high pressure would give one no larger. Thus the spring strength or scale is an item in calculating the effective pressure of the engine giving the diagram.

The indicator is fully explained in the chapter on steam.

Determining the Speed.—Knowing the mean effective pressure of the engine, the only undetermined element in the above formula is the speed, expressed as revolutions per minute of the fly-wheel, which being halved gives the number of explosions per minute for a four-cycle engine. The readiest method is to test with a tachometer (speed-meter), an instrument consisting of

a rod which is pressed against the end of a rotating shaft, so as to be rotated with its motion, and record the number of such revolutions per given time on a dial.

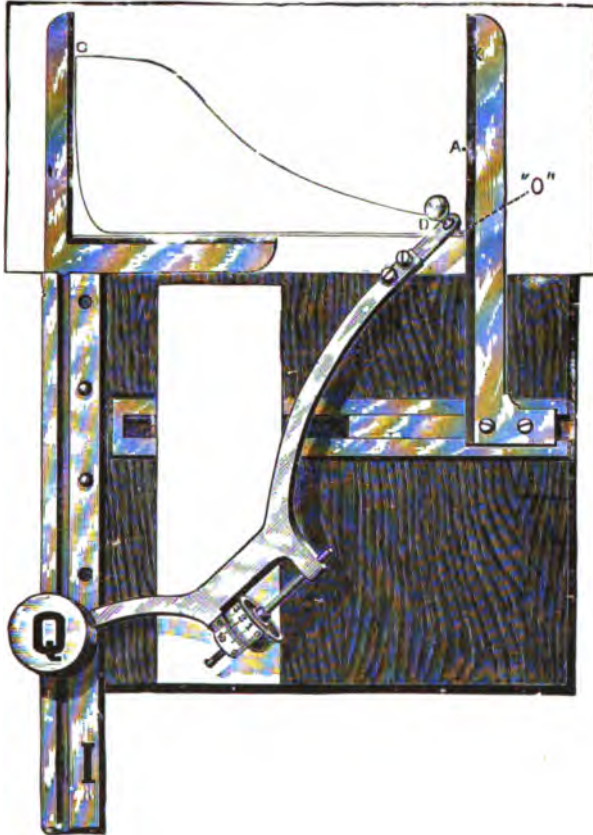

FIG. 310.—Method of Averaging a Diagram with one Type of Planimeter. The pin, *Q*, is set in the groove, *I*. The card is held on the board between clamps, *C* and *A*. The tracing point, *O*, is set at point, *D*, and the arm moved clockwise, the vernier and drum having been set at zero.

Average Figures for Speed—A fair average figure may be substituted in the formula given above for indicated horse-power, when the revolutions per minute are not known. It may be found as follows: Since the piston speed of most motor carriage engines running at full power is somewhere between 400 and 600

feet per minute, we may take the average of 500 feet, multiply it by 12 to reduce to inches and divide by twice the length of the stroke in inches. Thus:

$$\frac{6,000}{2 S} = \text{R. P. M.}$$

Twice the stroke is used because that expresses the space covered by the piston in each revolution of the fly-wheel. Substituting this formula in the typical engine mentioned above, we find that:

$$\frac{6,000}{9} = 666 \text{ revolutions per minute,}$$

which is very nearly the correct figure.

Roberts gives a more complicated formula, as follows:

"The following formula representing average practice among manufacturers will be found valuable in making the first approximate calculation:

"Let H = the D. H. P. of the engine;
Let R = the revolutions per minute;
Then for a four-cycle engine

$$R = \frac{380}{(H)^{.21}}$$

"In order to solve the above equation it is necessary to use logarithms. Suppose it is desired to find the speed of a 15 H. P. four-cycle engine. Take a table of logarithms and find first the logarithm of 15, which is 1.176091; multiplying by .21 the result is .24697911, which is the logarithm of 15 to the .21 power. The logarithm of 380 is 2.579784; subtracting the logarithm of $(15)^{.21}$ from this, we have 2.332705, which is the logarithm of 215.1. The proper speed for this engine is 215 r. p. m. or thereabout."

Estimating Power Without Diagrams.—The formulæ given above depend for exact results on the measurement of indicator diagrams. But it is possible to compute roughly without these. An authority quoted previously gives the following:

"When an estimate of an engine's capacity is desired, and no

diagrams are obtainable, the approximate horse power attainable in the cylinder may be found by means of the formula :

$$\frac{E \times V \times C}{1,000} \times \left(\frac{P'' - PE \times RE}{120} - \frac{PC - P' \times RC}{140} \right) = \text{H. P.}$$

"No doubt the formula will seem rather complicated at first glance, but its application is by no means difficult. Stated as a rule it reads as follows :

"Multiply the *exhaust pressure* by the *expansion ratio*, and subtract the product from the *explosion pressure*; divide what is left by 120, and call the result the '*first quotient*.'

"Multiply the *initial pressure* (about 13.2) by the *compression ratio*, and subtract the product from the *compression pressure*; divide what is left by 140, and call the result the '*second quotient*.'

"Subtract the *second quotient* from the *first quotient*, and multiply the remainder by the *number of explosions per minute* and by the *clearance volume*; divide this result by 1,000."

By attentively reading this rule the quantities may be readily recognized on the formula where they are designated by their initial letters.

The same authority gives another formula based on average figures as follows: Take the figure for the difference between the *exhaust pressure* and the *initial pressure* (13.2). Multiply it by a figure representing the average found by adding the *compression ratio* and *expansion ratio* and dividing by 2. Subtract the product thus found from the figure for *pressure rise*, which is to say the difference between the *pressure of explosion* and the *pressure of compression*. Divide the remainder by 10. Multiply the *quotient* thus found by the product of the *number of explosions per minute* and the *clearance volume*, and divide the product by 10,000.

Expressed graphically this gives us :

$$\frac{E \times V \times C}{10,000} \times \frac{(P'' - P' C) - (P E - P' \times \frac{r \times c \times re}{2})}{10} = \text{H. P.}$$

Estimating the Power by Prony Brake.—The most satisfactory method of testing the effective power of an engine is by the use of Prony's brake, one form of which is shown herewith.

Briefly, it consists of a band of rope or strip iron—the latter is the arrangement shown—to which are fastened a number of wooden blocks, several carrying shoulders to prevent the contrivance from slipping off the wheel rim. Being applied to the circumference of the fly-wheel the brake band is drawn tight, as shown, so that the blocks press against the surface all around. The brake, thus formed, is prevented from revolving with the fly-wheel, by two arms, attached near the top and bottom centres of the wheel, and joined at the opposite ends to form a lever, which bears upon an ordinary platform scale, a suitable leg or block being arranged to keep its end opposite to the centre of the shaft. By this arrangement the amount of friction between the brake band and the revolving wheel is weighed upon the scales. For since the brake fits tightly enough to be carried around by the wheel, but for the arms bearing upon the scale, the amount of frictional power exerted by the wheel in turning free within the blocks may be transmitted and measured, just as would be the case were a machinery load attached, instead of a friction brake.

The Factors in the Formulæ.—Accordingly, the factors in estimating the power developed are: (1) The circumference of the wheel; (2) the length of the leverage, measured on the line drawn from the centre of the rotating shaft to the centre of the scale platform; (3) the number of revolutions per minute; (4) the weight in pounds registered by the scales, less the static weight of the brake lever arms and block resting on the platform. With this form of Prony brake the formula for delivered horse-power is as follows:

$$\frac{W \times N \times L \times C}{33,000} = \text{B. H. P.}$$

in which *W* is the net weight as shown by the scale; *N*, the number of revolutions per minute; *L*, the length of the leverage; *C*, the circumference of the braked fly-wheel. Their product gives the number of foot-pounds developed; the quotient of the indicated division by 33,000 gives the efficient horse-power. If, therefore, a given engine has a fly-wheel of 16 inches diameter, revolving at 600 revolutions per minute, and giving 27.5 pounds

at the scale, with a leverage of 5 feet, we have, according to the above formula :

$$\frac{27.5 \times 600 \times 5 \times \frac{3.14159 \times 16}{12}}{33,000} = \frac{346830.57}{33,000} = 10.51 \text{ horse power.}$$

The diameter, 16 inches, being multiplied by 3.14159, the expression for the ratio between the circumference and diameter of a circle, gives 50.2655 inches, which, divided by 12, gives 4.189 feet approximately.

Other Forms of Prony Brake.—In some forms of Prony brake the block-bearing rope or band, instead of being secured as shown in the cut is attached to the floor and ceiling—two dynamometers or spring balances being interposed. Thus in the formula for estimating with this form, the item of leverage length is omitted, the expression being :

$$\frac{W \times N \times C}{33,000} = \text{D. H. P.}$$

As may be readily understood the scale weight in this case would equal the product of the weight and leverage length with the other formula.

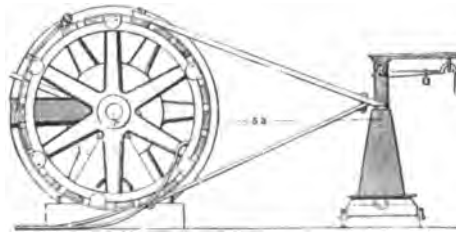

FIG. 310a.—Common Form of Prony Brake, for testing the D. H. P. of an engine. An iron band shod with wooden blocks is drawn tightly around the circumference of the fly-wheel. To this two arms are attached, the other ends of which bear upon the scale platform, as shown. It is necessary that the scale platform be raised to the same height as the centre of the fly-wheel shaft. The length of leverage is indicated as 5 feet 3 inches, the diameter of the wheel being 3 feet. These two factors, the R. P. M. and the recorded weight, are the essential elements in the determination of power as by the above formula.

CHAPTER TWENTY-NINE.

ON CARBURETTERS AND VAPORIZERS.

Carburettling Devices of Various Descriptions.—In operating a gasoline vehicle motor, it is essential that the liquid fuel be transformed into a gas, so as to be fed to the cylinders with a suitable mixture of atmospheric air. This process is performed by a device known as a carburetter, which consists in general of a vessel into which a small amount of liquid gasoline is admitted as required, and being there vaporized by air, which is passed through it or over it, and by the suction of the piston causes the gasoline to rise through a small orifice and mix with the passing air current in the form of spray. There are two common forms of carburetter; the surface carburetter, in which a current of air passing over the surface of the liquid gasoline, absorbs a certain portion of it, and the float feed carburetter, or sprayer, in which a current of air is drawn by the suction of the piston stroke, causing a spray to rise from the gasoline through a nozzle, the level of the liquid being continually maintained by a float controlling a needle valve to the supply tank. A third form, the filtering carburetter, has several points of resemblance to the simple mechanism sometimes employed for vaporizing gasoline for the purpose of illuminating houses. The gasoline is contained in a suitable receptacle, which stands in a cistern filled with water to a certain level; a cylindrical cover, balanced by a weight passing over a pulley, is suspended in the cistern over the gasoline receptacle, and is caused to rise by the pressure of air that has been pumped through the liquid gasoline and has absorbed a sufficient portion of it to render the mixture of air and gas inflammable. This mixture is then fed to the pipes leading to the gas burners in the house.

Air thus charged with the vapor of gasoline, or other volatile spirit, is said to be carburetted. In the practical construction of carburetters for gasoline vehicle use, a number of points must be considered, since in the use of such a device of any pattern, the elements of jar and vibration likely to disturb the operation

of the instrument, must be provided against. Also, for numerous other reasons, only a portion of the total fuel carried is acted upon by the air current at one time in the carburetters.

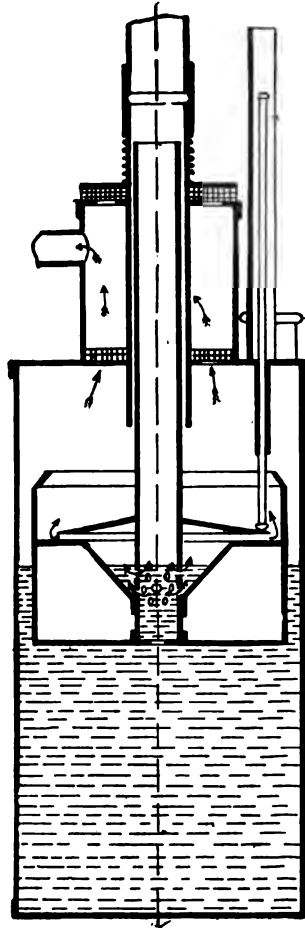

FIG. 811.—The Daimler Surface Carburettor, used on the early Daimler cycles and carriages.

Daimler's Surface Carburettor.—The idea of using liquid fuel for a gas engine, and carburetting it by a suitable instrument, was one of the improvements introduced by Gottlieb Daimler.

Daimler's carburetter, a section of which is shown in an accompanying illustration, was used on the earliest motor vehicles, tricycles and carriages made by him. It was a very efficient instrument in its day, but represents a style of construction that has been entirely superseded. It consisted of an elongated cylindrical vessel, which was partially filled with gasoline. Upon this liquid was a hollow cylindrical float, the shell of which was slightly depressed upon the upper face, so that the gasoline rising through the hollow in the centre could be readily exposed to the action of the air, drawn through the vessel by the suction of the piston. The float also carried a vertical tube, which reached upward through the top of the inclosed cylindrical vessel, sliding freely in a second tube of larger diameter, in order that the float might rise or fall to the level of the gasoline. In the top of the cylindrical vessel was also set a cylinder of somewhat smaller diameter, having a perforation in its top admitting atmospheric air, and having its base connected with the interior of the main cylindrical vessel. These openings at both top and bottom could be regulated by rotary valves. At the left-hand upper side of this cylinder was a vent, which was connected with the combustion chamber of the cylinder. The operation was as follows: When the piston began the suction stroke, air was drawn through this vent, some of it coming through the upper openings already mentioned, and another portion through the vents at the base, which connected it with the main body of the instrument. The air from within this main cylinder was drawn downward to the operating tube; the greater portion of it, as may be understood from the figure, passing through the small holes in the base of the tube, thus upward through the gasoline contained within the central depression of the body of the float, causing vaporization and thoroughly charging the air drawn into the cylinder. As may be seen from the illustration, the upper cylinder, which is in connection with the combustion space, has its vents covered with wire gauze; the object of this was to prevent the ignition of the contained gasoline and vapor, in case of back-firing in the cylinder.

Maybach's Float Carburetter.—On later vehicles made by Daimler were used the balanced float feed carburetters invented by his collaborator, William Maybach. As first constructed by

him, this style of instrument was the simple device shown in the accompanying cut. The float, *A*, contained within a small vessel connected by a tube, *B*, with the valve chamber of the cylinders, *F*, bears upon its upper face the spindle of a needle valve, which regulates the rate at which the gasoline is admitted to the carburetter through the tube shown at its top. This is the simplest form of the float feed carburetter. The action is as follows: When the piston in the cylinder, *F*, is making its suction stroke, the valve, *D*, is opened inwardly, compressing the spring, *E*, carried on its stem, and giving admission to atmospheric air, as indicated by the arrows. Since, however, the end of the tube, *B*, which is reduced to form the spraying nozzle, occupies the greater part of the air inlet, the strong spray of liquid gasoline is drawn

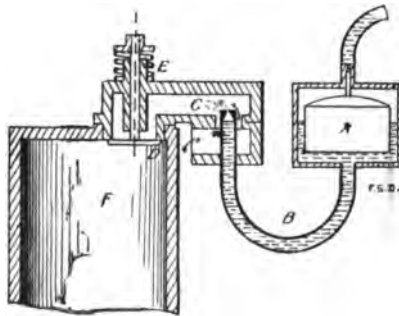

FIG. 312.—Maybach's Original Float Feed Carburetter. *A* is the hollow float carrying the spindle of the needle valve at its top; *B*, the tube leading into the inlet valve space; *C*, the spraying nozzle; *D*, the inlet valve; *E*, the inlet valve spring; *F*, the cylinder space.

up by suction and mixes with the atmospheric air in the valve chamber, *C*, the proportions of the mixture being determined by the dimensions of the apertures admitting additional air into the cylinders. The defects of this instrument are obvious; for since the float, *A*, is not balanced in any manner, its action was liable to be uncertain through the vibrations of travel, with the result that its regulation of the level in the float chamber would be uncertain if the valve stem were not wrenched or broken so as to render the machine useless. Largely from the considerations just noted, later types of the float feed carburetter have been constructed with a very elaborate and reliable adjustment to secure the maintenance of the desired level and the certain action of the

needle valve. The method of admitting air to mix with the gasoline spray under suction of the piston has also been so improved as to permit of considerable adjustment of the proportions in the fuel mixture.

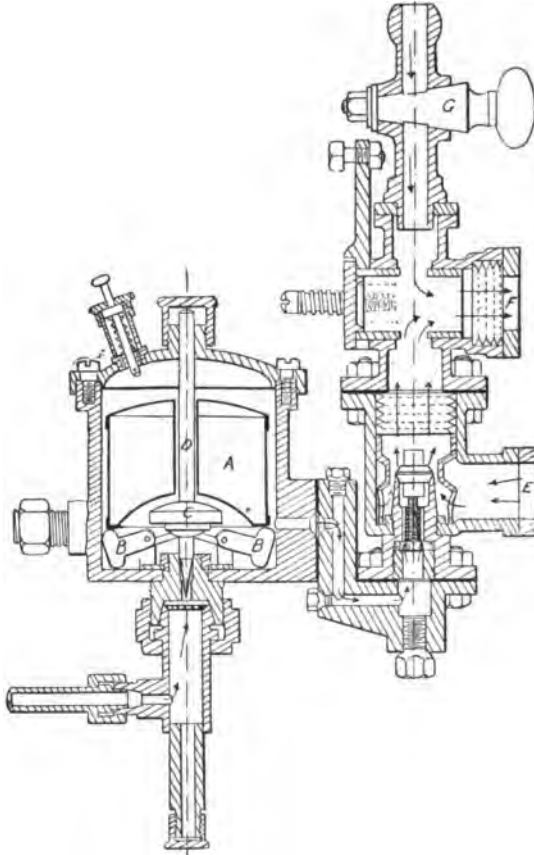

FIG. 318.—The Longuemare Float Feed Carburettor. A is the float; B, B, the weighted levers controlling the needle valve; C, the weight holding the needle valve closed while the lever is right in the float chamber; D, the spindle of the needle valve; E, air inlet; F, pipe communicating to combustion space of cylinder; G, cock for admitting additional air supply.

The Longuemare Float Feed Carburettor.—The Longuemare carburettor, shown in an accompanying illustration, is one of the most elaborate variations of the Daimler-Maybach type.

The carburetter chamber contains the float, *A*, through which passes the stem of the needle valve, *D*; this needle valve, however, is not attached to the float as in the earlier model, but is normally held in place by the weight, *C*, which holds the port leading to the gasoline tank normally closed. On either side of the weight, *C*, is fixed a small lever in such a fashion that when the liquid gasoline is at the required level and the float in the raised position, they are also held up by the weight, *C*, bearing upon their inner arms. When, however, the level falls, the float, *A*, bears upon the pivoted weighted arms, *B* and *B*, at the opposite extremities, pressing them downward, as shown in the illustration, and causing the weight, *C*, carrying the valve, *D*, to be raised upward, thus opening the inlet for the liquid gasoline until the normal level is once more restored. The mixing chamber shown in connection with this type of carburetter is considerably more elaborate than the one used with the Maybach just described. The tube, *F*, leads to the combustion chamber of the cylinder, and when the piston is making its suction stroke atmospheric air is drawn through the tube, *E*, passing around the adjustable valve-shaped nozzle leading from the float chamber. This valve-shaped nozzle is of interesting construction, consisting of a head having the general form of a mushroom-valve, to the base of which is a threaded stem, permitting of adjustment in the size of the orifice, through which the gasoline spray is drawn by the suction of the piston. Directly above this valve-nozzle are fixed several layers of wire-gauze, through which the carburetted air passes on its way to the vent, *F*. At the point, *F*, as shown, there are several other layers of wire-gauze. Their object is principally to prevent all danger of explosion, or of disablement, to the instrument in the event of burning-back, which is liable to take place if the inlet valves are not arranged to close promptly, or if they should be in any other fashion disabled. The quantity of air admitted to the carburetter through the inlet port, *E*, is controlled by a cylindrical valve having the same general construction as an ordinary faucet, the opening of which is controlled by the upright arm shown just below the cock, *G*. A still further adjustment of the mixture, particularly when a larger portion of air is desired, may be obtained by opening this cock, *G*, and admitting the air from above. In spite of its complication, this instrument has been very widely used.

The Peugeot Carburetter—The float feed carburetter used on the Peugeot carriages, although simpler in its general details, has many of the excellent features of the instrument just described. In this also, the needle valve is held on a rod which passes through the body of the float, being also held in a depressed position, so as to close the vent by a weight, which is raised by pairs of pivoted levers under the weight of the float whenever the level sinks below the required point. The mixing tube is connected at the base with the combustion chamber of the cylinder, admitting air through the tube coming in vertical direc-

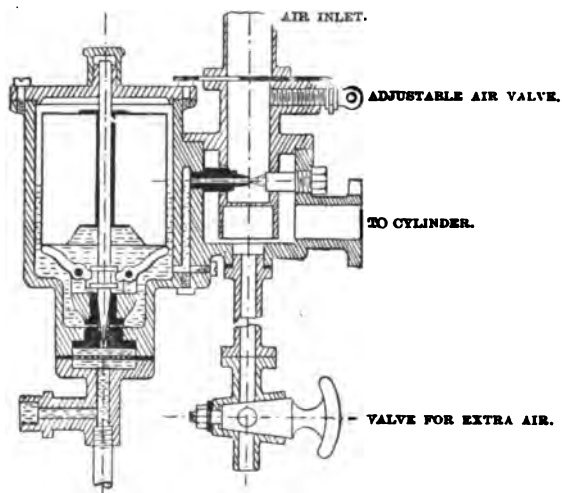

FIG. 814.—The Peugeot Carburetter. This has many points in common with other carburetters, except that the valve levers are differently arranged; the spraying nozzle at the side of the mixing tube, and the air-inlet from above.

tion from above, the spray being drawn through the nozzle, which is shaded in black. This nozzle is of the ordinary pattern with a reduced mouthpiece. Directly above it is an adjustable sliding valve, controlled by a turn-screw in the wall of the chamber, which varies the quantity of air admitted, and hence also the richness of the mixture. Additional air may also be admitted when desired, through the tube leading from the base of the mixing chamber, controlled by the cock as shown.

The Perfected Daimler Carburetter.—The float feed carburetters used on the later patterns of the Cannstadt-Daimler carriages, and also on those manufactured in France by the firm of Panhard-Levassor, are in several respects similar to the one last described. In these carburetters the spindle of the needle-valve is passed through the tube in the centre of the float. From the top of the gasoline chamber hang two small supports, into which are pivoted levers working in a collar on the valve rod at one extremity of each, and having weights bearing upon the top of the float at the other. The top of the spindle pro-

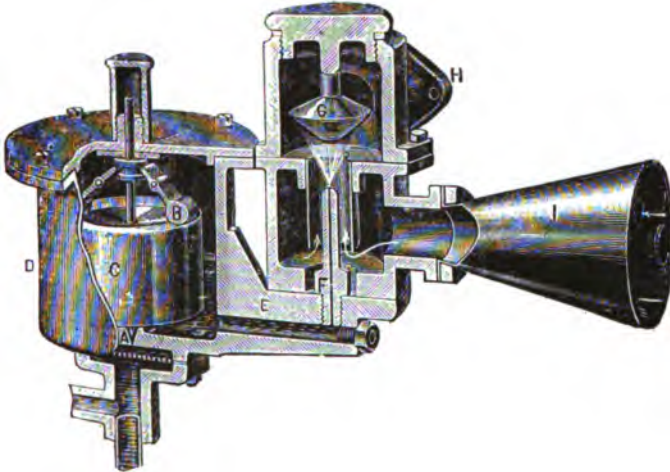

FIG. 315.—The "Phenix" Daimler Carburetter. A is the gasoline needle valve; B, the weighted controlling levers; C, the float; D, the float chamber; E, the gasoline supply tube; F, the spraying nozzle; G, the "mushroom" spray deflector; H, the port leading to the cylinder chamber; I, the air inlet. The air entering the mixing chamber follows the course of the arrows.

trudes through the cover of the float chamber and is normally held in a depressed position by a spring bearing upon its end, thus ensuring the closure of the needle-valve and the stoppage of the gasoline feed so long as the desired level is maintained; as soon, however, as this level falls, the weighted extremities of the two levers are depressed, causing the opposite ends to bear upon the collar on the valve spindle, thus forcing it up and opening the valve. In the lettered section of this carburetter, we may see the needle-valve at A, be-

low it being shown the supply pipe leading from the gasoline tank, and the layer of wire-gauze interposed just below the entrance to the float chamber. The simple weighted levers are shown at *B*, the hollow float at *C*, the passage for the admission of air at *I*, and the passage leading to the combustion chamber at *H*. The operation is precisely similar to that of the other carburetters already described. Directly above the spring nozzle is fixed a cone, or deflector, *G*, which serves to disperse the spray which is forced against it by air pressure, thus securing, as asserted, the more complete and uniform mixture of air and gasoline vapor.

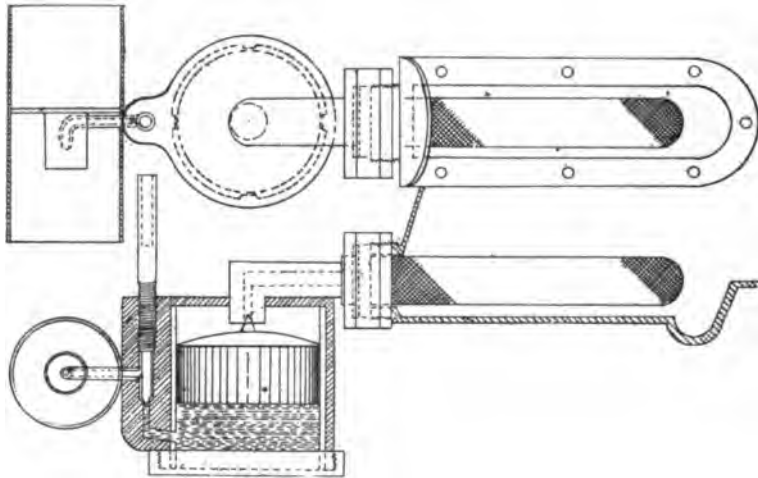

FIG. 316.—The Duryea Float Feed Carburettor or Sprayer.

The Duryea Float Carburettor.—A large proportion of gasoline carriages manufactured in America have, up to the present time, been equipped with float carburetters of the same general construction as those already described. Very exaggerated claims are made by several manufacturers as to the superiority of their own contrivances, but the principal innovation which they can show seems to consist in improved devices for securing undisturbed action of the needle-valve, and for regulating the proportions of the fuel mixture fed to the cylinder. The Duryea carburettor, or sprayer, shown in an accompanying cut, is per-

haps one of the simplest among those produced in America. Like the float feed carburetters already described, it has a gasoline chamber in which is placed a hollow cylindrical float; this float, like that used in the earliest form of the Maybach carburetters, carries the point of the needle-valve secured to its top, thereby closing the entrance of the gasoline from the tank through the top of the float chamber, so long as the proper level is maintained within. Unlike the early Maybach carburetter, however, this

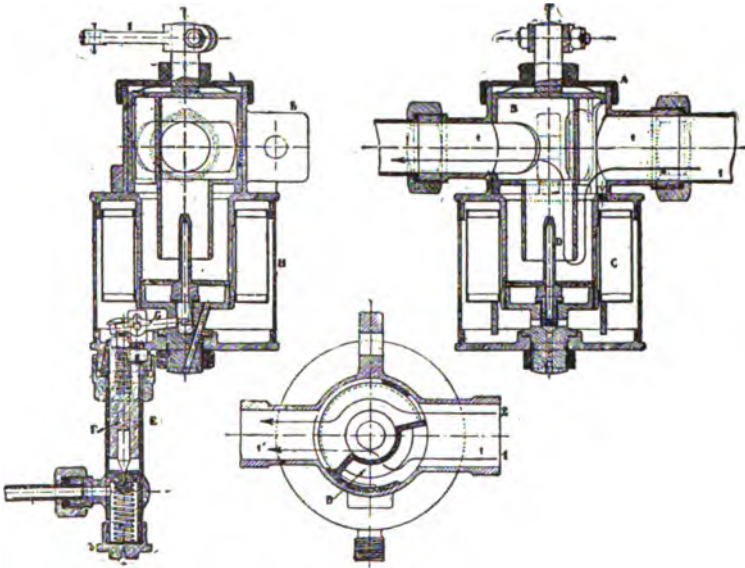

FIG. 317.—The De Dion & Bouton Vaporizer. A is the cover of the air chamber; B, the air valve; C, the float; D, the mixing chamber; E, gasoline supply; F, gasoline needle valve; G, valve controlling lever. Arrow (1) indicates course of air through mixing chamber; arrow (2), course of additional air through valve B.

float is balanced by vertical guides at four points on its circumference, as may be readily understood from the plan and sectional views given herewith. Connected with the float chamber is a vertical passage, whose height may be controlled by an adjusting screw, shown in the figure, and which connects to a spraying nozzle, extending into the tube or passage from atmosphere to the combustion chamber of the cylinder. As shown in the plan view, the spraying nozzle is bent around to a right angle

at the end and is enclosed in a short length of small diameter tubing. The inflow of air through the larger tube is controlled by an adjustable rotary valve. The liquid gasoline is fed to the float chamber from the supply tank through a length of tubing encased in a cylindrical cover of wire-gauze, intended primarily to prevent the passage of any impurities which might interfere with the action of the needle valve or clog the small passages leading to the spraying nozzle.

The De Dion Float Carburetter.—The float feed carburetter, used on the later models of the De Dion & Bouton gasoline carriages, combines several features in radical departure from the patterns of carburetter already noticed. As shown in the accompanying sectional plan and elevations, it consists of a cylindrical chamber, *H*, within which is contained a float, *C*. This float differs from the kind used on other carburetters in the fact that it is constructed out of two annular cylindrical shells, united by flanged and soldered ring heads. Its shape, with the hollow space in the centre, makes possible the construction allowing the mixing chamber to be set in the centre of the float chamber, the float surrounding it and sliding against its cylindrical walls. The supply of gasoline is admitted to the float chamber through the adjustable valve shown at *F*, the opening and flow being controlled by the lever, *G*, which, as shown, is in a raised position, thus allowing the needle-valve to be closed, so long as the weight of the float does not bear upon it. The spraying nozzle is located in the mixing chamber, which, as already stated, is entirely surrounded by the ring-shaped float. The gasoline is drawn by suction through this nozzle by the air entering the tube, *t*, and following the direction indicated by the arrow, marked 1 (one) in the plan and right-hand sectional elevation. As shown in the plan, there is also a cylindrical valve, *B*, which may be rotated by the lever, *I*, attached to the stem passing through the cover, *K*, of the upper chamber, *A*. By this handle the charge may be throttled within the desired limits by regulating the inflow of additional air through the tube, *t*, as indicated by the arrow, marked 2 (two) in the plan. This carburetter has the advantage of compactness and simplicity of construction. Another form of float feed carburetter used on De Dion carriages is shown in Fig. 282. It assimilates the common patterns.

The Huzelstein Valve Carburetter.—From the earliest days of the use of liquid fuels for explosive engines, numerous inventors have produced designs of carburetters or vaporizers that operate without the complications of a float chamber and needle-valve, whose opening is regulated by the level of the gasoline contained therein. One of the most typical devices of this de-

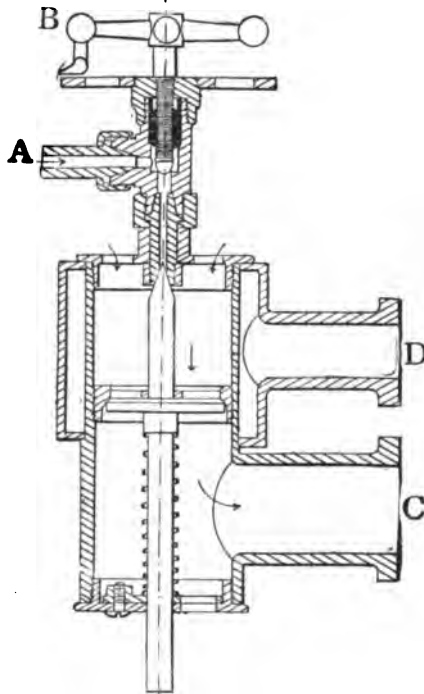

FIG. 318.—The Huzelstein Carburetter. A is the inlet for gasoline; B, the valve controlling inlet; C, the tube leading to cylinder combustion space; D, tube for leading hot exhaust gases around the jacket on the mixing chamber. Arrows indicate entrance for air and course of mixture to cylinder.

scription is the Huzelstein, or "Universal," carburetter, shown in an accompanying illustration. It consists of a vertical cylindrical chamber, within which is a valve controlled by a helical spring and hung on a spindle, the upper end of which forms a needle-valve, closing the inlet port for liquid gasoline, shown at the top of the cylindrical chamber. The gasoline from the supply tank

is fed through a tube, *A*, leading to this chamber and having its rate of supply regulated by a needle-valve carried at the end of an adjustable screw shank, upon the upper end of which is the handle, *B*. Connection with the interior of the main cylindrical chamber and the combustion space of the cylinder is had by the tube, *C*. The tube, *D*, is also connected with the combustion space so as to permit the heated products of combustion to circulate through the jacket or passage around the upper part of the mixing chamber above the valve. The suction of the piston operates to open the valve, drawing it from its seat and depressing the helical spring around the lower portion of the valve spin-

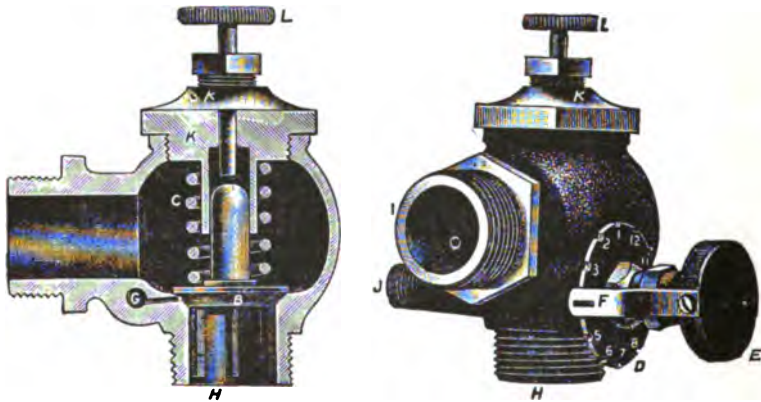

FIG. 319.—The James Valve. B, fuel inlet valve; C, spring controlling B; D is the scale dial showing proportions of air and gasoline; E, the wheel controlling gasoline valve; F, clip or top for holding E in position; G, gasoline supply tube; H, air inlet; I, entrance to cylinder; J, entrance for gasoline; K, cover of valve chamber; L, wheel and spindle controlling tension of spring, C.

dle. This process, of course, opens the needle valve leading from the gasoline feed pipe and permits the inflow of a small quantity of liquid gasoline. This is mixed with the air drawn through the opening indicated by the arrows at the top of the chamber, the process of mixing being perfected by the heat of the vapors passing through the tube, *D*, and around the chamber in connection with it; also, by the friction experienced in passing through the narrow clearances between the open valve and its seat. Between the periodic suction strokes of the piston, the air in the upper portion of the mixing chamber above the valve is made to absorb some of the heat circulating around it, and hence, according

to the theory of the inventor, is better prepared to mix perfectly with the gasoline mist. This carburetter has seen considerable use in France and some other European countries.

The James-Lunkenheimer Valve.—Several well-known makes of American carburetters are constructed to operate along the same general lines as the Huzelstein, and, like the majority of American improvements in motor vehicle construction, have the advantage of greater simplicity, strength and compactness. Among these we may mention the James mixing valve, shown herewith. This device consists of a globular valve chamber having three openings or vents, *H*, *I* and *J*. As shown in the sectional view, the opening, *H*, is closed by the mushroom valve, *B*, under tension of the spring, *C*. The passage, *I*, is connected direct to the combustion chamber of the cylinder, and at the suction stroke of the piston, the air is drawn through the tube, *H*, its pressure causing the valve, *B*, to rise from its seat. The air drawn through the passage, *H*, also draws as spray a small portion of liquid gasoline through the tube, *G*, which connects through the passage, *J*, with the gasoline supply tank; thus securing a very good fuel mixture, according as the play of the valve, *B*, and the opening of the tube, *G*, are adjusted. The proportionate amount of gasoline fed into the cylinder through the passage, *J*, of the tube, *G*, is controlled by a needle-valve carried on the spindle at the hand-wheel, *E*, the proportionate opening of the valve being indicated on the graduated disc, *D*, by the position of the clip, *F*. The play of the valve is also regulated by the position of the spindle carried on the hand-wheel, *L*, which is threaded so as to be raised or lowered as required. Mixing valves of this description have been adopted on several makes of American gasoline carriages, notably the Winton, with apparently favorable results.

The Improved Filtering Carburetter.—Another interesting carburetting device, also of American design, and known as the "Auto Carburetter," is shown in an accompanying illustration. Here connection to the gasoline supply tank is had by port, *B*, leading into a simple globular chamber, through which is fixed the spindle of an adjustable needle-valve, controlling the entrance to the cylindrical chamber, *K*,

within which are fixed, at a slight incline, eight semi-circular pieces of wire-gauze. The gasoline, admitted through the opening of the needle-valve, drips upon these pieces of gauze, any overflow from one falling to that next below it, so that the air drawn through the ports, *C*, opening into the top of

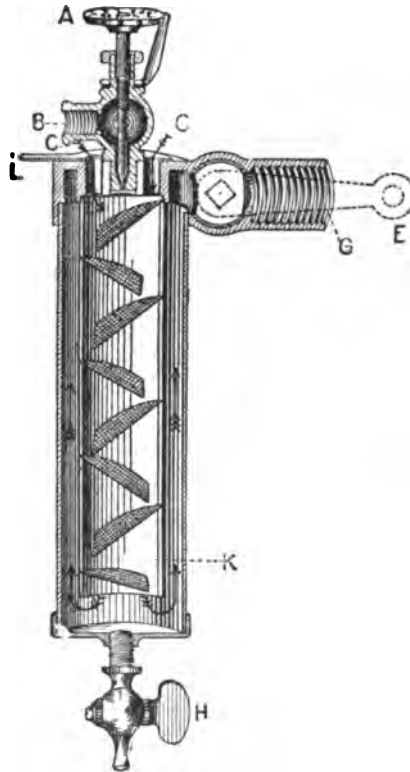

FIG. 320.- The "Auto" Carburettor. *A*, wheel controlling needle valve; *B*, gasoline inlet; *C*, *C*, air inlets; *E*, throttle lever; *G*, pipe to cylinder; *H*, drip cock; *K*, inner cylinder containing segments of wire gauze; *L*, valve controlling air inlets.

the cylinder, becomes thoroughly charged with gasoline mist before reaching the bottom, connection being made with the combustion space of the cylinder through the tube, *G*, which connects direct with another larger cylinder placed outside of the first. The air is drawn through the layers of gauze down through the

inner cylinder to its bottom, then up and around it. The opening of the gasoline inlet tube, *G*, is controlled by a cock, *F*, on the rod, *E*, so that the amount of mixture may be varied or the tube entirely closed. The drain cock, *H*, is fixed at the base of the outer cylinder, so as to carry off any leakage of gasoline or unvaporized residue that might collect within it.

Supplemental Mixing Chambers—Many of the earlier types of explosive motors for vehicle use were equipped with a mixing chamber in addition to the carburetting device. This mixing chamber in its typical construction, as used on the Benz carriages and some of the Daimlers, consisted of two tubes telescoped together, the inner one of which had longitudinal openings, so that, the further it was pulled out from the outer tube, the larger the amount of air that was admitted with the carburetted mixture under the suction of the piston. To diminish the air supply, the same tube was pushed in. However, in later engines of the four-cycle type, the practice of drawing in atmospheric air, in addition to that coming through the carburetter, has been abandoned, and carburetters are now constructed, as we have seen, with air and gasoline inlet valves that may be adjusted so as to vary the proportions of the mixture passing through the instrument. There is thus but one inlet valve to the cylinder, and that is used solely for admitting the regulated fuel mixture from the carburetter.

Troubles With Carburetters.—Under ordinary circumstances, as in summer or in dry weather, the process of carburetting the liquid fuel, so as to form a mist or vapor, suitable for explosion in the cylinder, is very readily perfected with mineral spirit of the proper quality. It has been found, however, that cold and damp weather are apt to materially reduce the volatility of the liquid, with the result that the power efficiency of the motor is oftentimes reduced nearly one-half. In order to partially combat this difficulty, numerous motor carriage builders, both in America and abroad, have arranged to place the carburetting device in or near the muffler, so that the heat of the exhausted residua of combustion may act to promote the carburettization of the fuel and, as far as possible, neutralize the ill effects due to unfavorable weather or temperature. The device is a desirable feature under

any circumstances; since, as has been recognized by numerous inventors, heat materially helps the process of vaporizing—heated air will absorb the vapor of gasoline much more readily than cold air; also heat will ensure the best possible results, even with the use of the poorer qualities of liquid fuel.

Kerosene Vaporizers.—Although for numerous reasons, such as its stench, dirtiness and inferior vaporizing qualities, kerosene has been used successfully in but few explosive engines, propelling motor carriages, the few employing it as fuel have embodied with the vaporizing device certain facilities for so preheat-

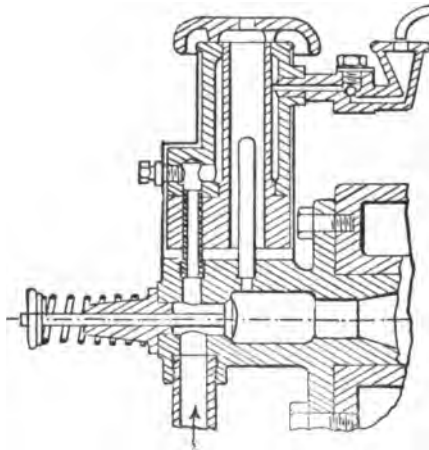

FIG. 321.—The Blackstone Kerosene Vaporizer. As is evident, the oil sprayed in at the right-hand top of the cylinder passes through an annular space around the "chimney" of the hot tube, passing thence to the space behind the inlet valve.

ing the liquid that the mist formed by the injection of air, under suction of the engine piston, is rendered as rich as possible. This provision is in obedience to the quality of kerosene, which renders it much more readily volatile when heated than when cold—for, although many qualities of this oil have the "flash point," at which inflammable vapors are given off, at a very low temperature, the process is greatly facilitated at higher temperatures, when also many of the heavier constituent elements may be taken up, as mist, by the air passing through, or over, the liquid.

A kerosene vaporizing device is shown in an accompanying

cut, which exhibits the construction to advantage. Upon the inlet valve chamber of the cylinder, and around the hot tube igniter opening into it, is set a metal chimney having an annular channel or jacket between its walls and entirely around its circumference. Into this jacket the oil, dripping from a small tube into a funnel at the upper right-hand of the figure, enters with air, also drawn into the funnel by piston suction; both flowing around through the jacket space, which is heated by the flame employed to keep the hot tube incandescent. The heat, acting on the oil and air, serves to break up the former into a mist, which is carried, through the channel at the left-hand lower portion of the annular jacket, to the chamber directly behind the inlet valve, as shown. At the suction stroke of the piston, the oil and air mist is drawn into the cylinder clearance, together with additional air coming through the tube shown at the lower left-hand corner of the figure. The proportions of the additional air supply being adjusted, as desired, the explodability and power of the charge may be regulated to power and speed requirements.

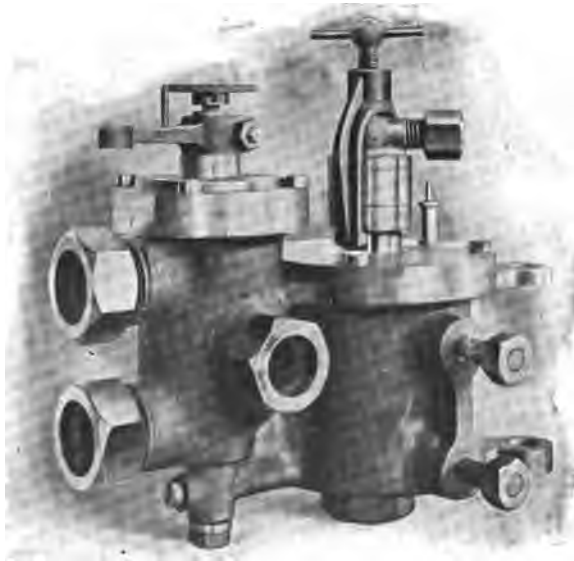

FIG. 322.—A Typical Float Feed Carburettor. This cut gives an outside elevation of the instrument shown in section in Fig. 282.

CHAPTER THIRTY.

ON THE SEVERAL METHODS OF FIRING THE CHARGE IN A GAS ENGINE CYLINDER.

Firing the Charge in Cylinder.—As already stated in a previous section, the fuel mixture of air and gas, after it has been drawn into the combustion chamber of the cylinder, is ignited explosively, thus being compelled to assume its maximum volume, by some source of heat which acts periodically. As also mentioned, there are several methods of accomplishing this result; several of them depending for operation upon the act of compressing the charge.

Firing the Charge by Heat of Compression.—In the Diesel four-cycle engine, the explosion of the charge is accomplished entirely by the temperature produced by the compression stroke. At the suction stroke of the piston, pure atmospheric air is admitted to the combustion chamber, and at the completion of the compression stroke, which in this engine extends all the way to the rear head of the cylinder, it is compressed to about 550 pounds to the square inch, which produces a temperature about equal to the heat of combustion. Very shortly after the beginning of the next out-stroke the fuel charge, which may be gasoline vapor, coal gas or atomized oil, is forced into the combustion chamber under the still higher pressure: the result is that its temperature, due to compression in an auxiliary cylinder prepared for that purpose, is already sufficient to ignite it explosively, and this result follows immediately it comes into contact with the oxygen of the air contained within the clearance of the cylinder. By the return stroke of the piston, the burned-out gases are entirely swept from the cylinder. While, according to authorities, the operation of the Diesel motor is very satisfactory in practice, the fact that it requires an auxiliary cylinder to compress the fuel gas to a very high degree effectually precludes its use for purposes such as motor vehicles, where all the available power is desirable for locomotion. It would also be quite impossible to operate it successfully without such press-

ure, or with fuel mixtures produced by any other form of carburetting device as above described.

Firing the Charge by Hot Head.—Another method of igniting the cylinder charge by hot walls and a temperature maintained by the act of compression is that used in connection with the Hornsby-Akroyd engine, already noticed. In this engine,

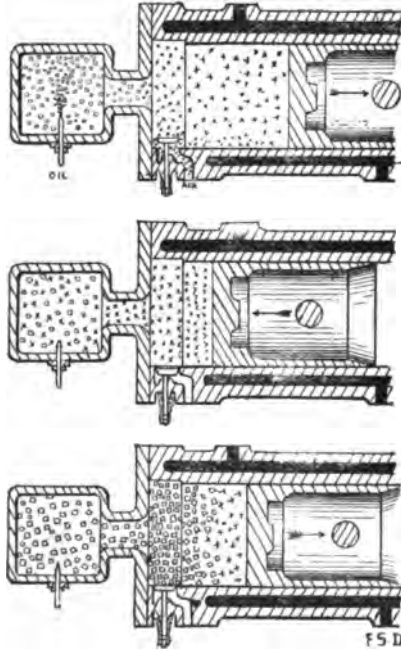

FIG. 223.—Diagram of the Hornsby-Akroyd Ignition System. At the end of the cylinder is a box, or chamber, connected to it by a narrow neck. During the suction stroke, shown in the first figure, air is drawn into the cylinder and oil sprayed into the hot igniting chamber.

the rear end of the cylinder is connected by a narrow passage with the closed chamber, whose general construction has been compared to a bottle or jug with a shortened neck; into this chamber also, at some convenient point, extends a vaporizing nozzle which is in connection with the source of liquid fuel supply. On starting the engine, the first act is to heat this hot chamber with a suitable torch, so as to bring it to the tempera-

ture required for exploding the charge. On the suction stroke of the piston, air is drawn into the combustion chamber of the cylinder through the ordinary poppet valve opening direct to atmosphere. At the same time, also, oil spray is forced through the atomizing nozzle directly into the hot chamber, where, although the temperature is fully sufficient to produce ignition, there is an insufficient quantity of oxygen to accomplish this result prematurely. The return stroke of the piston, compress-

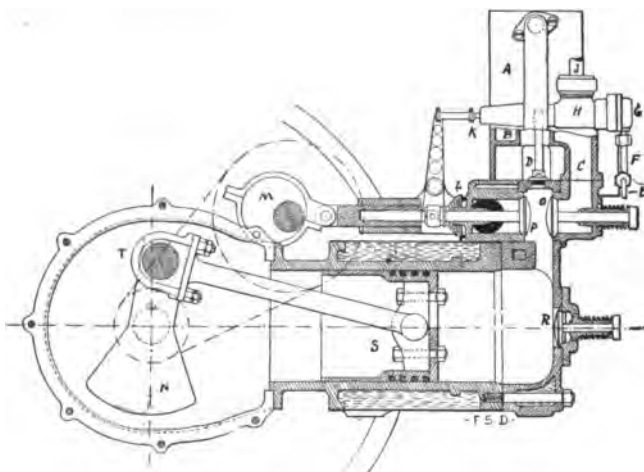

FIG. 324.—Roots' Kerosene Oil Motor for Vehicle Use. Sectional view showing the hot tube ignition, oil, vapor and air inlet and reciprocating parts. A is the vaporizing chamber surrounding the chimney of the hot tube, D. The eccentric, M, on the cam shaft actuates the exhaust valve, P, held in place by the spring, L, at the same time moving the link, K, which opens a valve contained in H, allowing a small amount of oil to be sprayed through the tubes, E, F, G, into the circulating chambers contained around the hot tube, D, as shown at B. The oil circulating around the heated space is transformed into vapor, which is fed into the channel, C, behind the inlet valve, O, which is opened by compression of its spring at the suction stroke. The valve, R, controlled by an adjustable compression spring, also admits sufficient air into the cylinder to give a mixture of the required proportion. The reciprocating parts are the piston, S, the connecting rod joined by a strap, T, to the crank pin, opposite to which is the balance weight, N. This section very well illustrates the workings of the type of explosive motor using hot tube ignition.

ing the air contained in the cylinder clearance to a very high degree, forces a certain portion of it through the narrow passage connecting with the hot chamber; and ignition immediately begins, the burning gases expanding and rushing into the cylinder during the succeeding out-stroke until the maximum volume is reached. After the engine has taken up its cycle, the temperature within the hot chamber is constantly maintained

by the succession of explosive ignitions at high pressure, in precisely the same fashion as that already described in connection with the Diesel engine; the external source of heat being then, of course, withdrawn.

Firing the Charge by Naked Flame.—The hot head ignition system has been used very little, if at all, in connection with engines using mineral spirits as fuel. It is also a comparatively

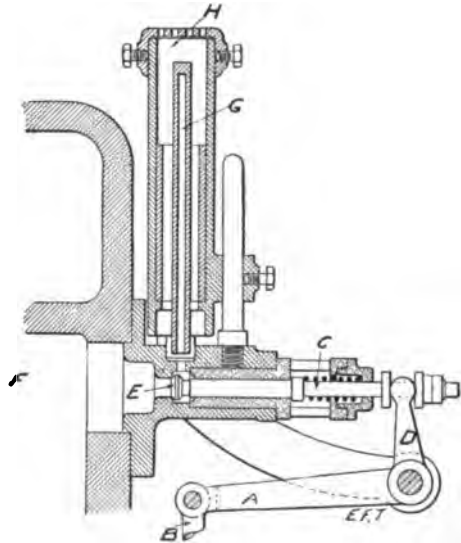

FIG. 325.—A Hot Tube Igniter, with a Geared Timing Attachment for Regulating the Point of Firing. G is the hot tube enclosed with a cylindrical case having a perforated cap, H, at the top. The heat of the tube is maintained by a gas flame within the cylindrical case. The link, B, operates the levers, A and D, so as to open the valve, E, which is normally held closed by the spring, C, bearing on its rod as shown. In opening the valve to the point in the cycle, at which the cam actuates the link, B, thus compressing the spring, C, and opening the valve, D, the interior of the hot tube, G, is brought into communication with the combustion chamber, F, of the cylinder. The time of ignition may be varied by adjusting the throw of the cam, so as to bring the opening of the valve E, to any desired point.

recent device, the earliest gas engines, as constructed by Otto and his collaborators, having a separately supplied and constantly burning gas flame, which was periodically connected with the combustion chamber of the cylinder by a peculiarly constructed slide-valve, the explosion of the charge being accomplished by a certain portion of the compressed mixture coming into contact with the flame. This method operated very well in

many cases, but was open to two grave objections, as recorded by numerous authorities. In the first place, the action of the slide-valve was uncertain and very often detrimental to the engine, since at high temperatures it was liable either to leak or to become jammed, owing to the expansion of its own metal. In the second place, the best effect of expansion in the burning fuel gas was not always secured, since, in addition to other difficulties, a large portion of the compressed mixture was liable to escape from the cylinder.

Firing the Charge by Incandescent Tube.—As a variation of and improvement on the above-mentioned device, the hot tube ignition was invented, the essential features of which are a tube of metal and porcelain, one end of which is connected direct with the combustion chamber, the other being closed. Around and against this tube the flame of a separately supplied gas burner is allowed to play, thus producing the required temperature for explosion. With some engines using hot tube ignition, the connection with the cylinder is controlled by a slide-valve in somewhat similar fashion to that used on the Otto engine, the valve being positively operated, so as to open and admit the compressed mixture into the hot tube at the proper point in the cycle. With others, there is no valve whatever, the act of compression alone operating to force the mixture into the tube and begin the process of ignition at or shortly before the end of the compression stroke. As may be understood, however, such an arrangement is liable to cause premature ignition under certain conditions, and is inferior to a well-gearred device for timing the moment of ignition. Accordingly, a "timing valve," positively operated from the cam-shaft, has been used with a number of gas engines. As shown in the accompanying illustration, the lever, *A*, attached to the push rod, *B*, is raised, thus pulling out the rod, *C*, by action of the arm, *D*, and opening the port, *E*, leading into the cylinder space, *F*. The compressed gases in the cylinder are then admitted into the hot tube, *G*, surrounded by a gas flame, as shown, and the process of ignition begins, spreading from the gas within the tube into the combustion chamber of the cylinder. The valve, *E*, is held open throughout the firing and exhaust strokes of the piston, so that it may be swept clean of the burned-out gases contained within it. Upon

the completion of the exhaust stroke it is closed, and so remains until, at the predetermined point in the cycle, the push rod is again actuated from the cam-shaft.

Troubles with Hot-Tube Ignition.—In most gasoline vehicle engines using the hot tube ignition, there is no provision, such as a geared timing valve of the general description noted above.

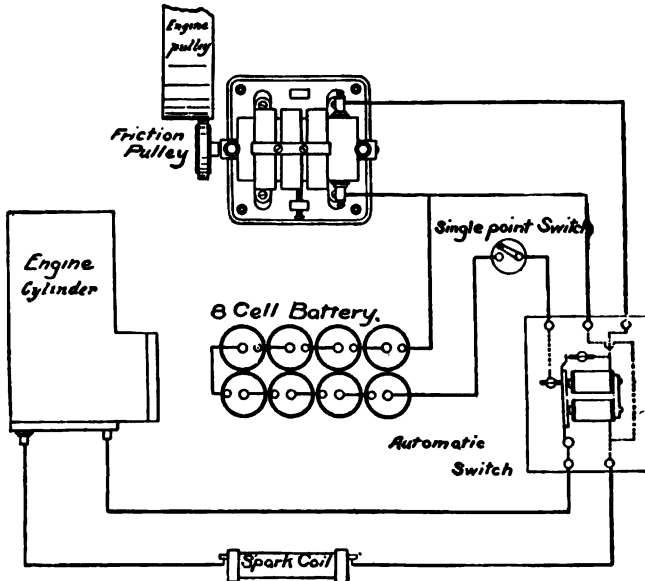

FIG. 338.—A Primary Spark Ignition Circuit, containing a magneto-generator, an 8-cell chemical battery, and an automatic cut-off or relay. The chemical battery is used to supply the current for producing the spark until the magneto-generator has attained its required speed. At that point the current from the generator passing through the coil of the automatic switch is sufficiently strong to cause the magnets of the relay to attract their armature and cut the circuit of the chemical battery. This circuit may also be cut out at any time desired with the single point hand switch.

Consequently, the hot tube opens direct into the combustion space of the cylinder—being closed from it at no time in the cycle. Some authorities have noted serious objections to the hot tube ignition system, alleging that, under various conditions, it causes either premature ignition or missed fire, on account of the presence of burned-out gases within it. Under some conditions, it is stated, the tube is so filled from end to end with these

residua that the charge in cylinder cannot come into contact with the incandescent walls, in order to ignite properly. Under other circumstances the tube is clogged with dead gases from its closed end nearly to the cylinder, and, when this condition is coupled with the fact that the heated portion is too near the entrance, premature ignition results before the completion of the compression stroke. Although these results may follow in a given type of engine, it is necessary to note several things: 1. The tube should be so constructed that the flame plays on that portion of its length which has been found to be at most suitable dis-



FIG. 327.—Details of a Common Form of Contact for Producing a Wiping Spark. The electrode, X, rotated by the crank, E, as indicated, gives a wiping contact and break at the terminal, Y, which is tipped by a resilient platinum spring. One of the wires forming the circuit is connected at D through the insulated plug screwed into the body of the ignition chamber; the other is connected to the metal of the chamber at the nut, M. The advantage of this form of sparking device is that the constant contact of the electrode keeps the surfaces clean, but at the same time the constant friction produces an immense wear for the same reason. An excellent form of simple make and break device is shown in connection with the suction of the Duryea cylinder in a succeeding chapter.

FIG. 328.—The Apple Magnetic Ignition Plug for Producing a Primary Spark. The two electrodes, as shown, are normally in contact, the coil contained within the cylindrical shell of the plug acting as a magnet to break the contact at the required point. As claimed by the manufacturers, the advantages of this device are ready adjustment and repair, a ready cleansing of the contacts, and the avoidance of any other coil than is used within the plug itself. The spark can also be controlled from the outside, the same as with the jump-spark coil, with the combined advantage of much greater simplicity of parts and circuit arrangements.

tance from the opening, not risking the danger of premature ignition, if it follows from such a cause only. 2. The tube should be heated to the proper temperature to secure the best and quickest ignition. 3. The temperature being properly arranged, the burned-out gases should be largely expelled from the tube by their own expansion under heat. 4. The compression ratio should be such that the fuel charge may be forced into the tube at the

proper point, in spite of and against the expanding tendency of dead gases clogging its interior. With a well-made tube, a properly adjusted compression and a powerful jet flame, there is no reason for such accidents as are above mentioned. They result rather from faulty construction or bad management.

On Electrical Ignition Systems.—Although some of the most effective types of gas and gasoline engines still use the hot-tube ignition system, a large majority of both are equipped with some form of electric-sparking device. Although there are numerous objections also to this method, it has the advantages of providing

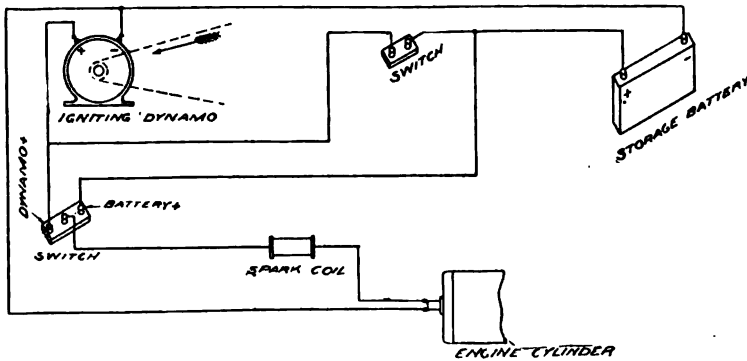

FIG. 229.—Diagram of a Primary Spark Circuit, equipped with a Dynamo and Storage Battery. The dynamo may be used to spark the engine and supply the battery at the same time, or to perform the former function exclusively. The battery is charged when the switch between it and the dynamo is thrown in, if the other switch "dynamo" in the cut. As is obvious from the cut, the dynamo may be cut out altogether, allowing the storage battery to supply current for sparking purposes. When both switches are in, the storage battery will supply current for sparking, until the dynamo has attained its full speed.

an entirely intermittent source of ignition, and of being much more flexible than any constantly existing source of heat, such as found in hot walls or tubes, thus being susceptible of a nearly perfectly timed ignition. The electric-sparking system, of course, requires some separate source of electrical energy, such as a battery of galvanic cells, a small dynamo, or a magneto-generator. The current thus generated is used to produce a spark, either from a primary or a secondary circuit; the former containing the ordinary reactance coil and producing a low-tension spark, from either a wiping or a breaking contact; the latter containing an induction coil and producing a high-tension spark between

slightly separated terminal points. The latter variety is commonly known as the "jump-spark." The sparks of both varieties are successfully used in motor carriages, although the high-tension circuit and the jump spark seems to be most usual on motor vehicles.

Typical Methods for Producing a Primary Spark.—The spark produced from a primary circuit, with either wiping electrodes or break contact, is due to the effort of the self-induced



FIG. 330.—The "Crest" Jump-Spark Plug for use in Vehicle Motors. As shown in the half-sectional view, the plug consists of two essential parts; the shell having a thread at one end to screw into an orifice in the combustion chamber, and carrying one terminal of the sparking circuit as shown. Through the inside of the shell is a tapered hole, in which an insulated cone is fitted gas tight. Through this insulation is inserted the other terminal of the circuit, which is a metal knob. This is in electrical contact with the wire screwed to the binding post at the end of the insulated tube. The other terminal is connected to the metal of the cylinder.



FIG. 331.—"American" Indestructible Sparking Plug. Like the one just shown, this plug has also two essential parts; the shell carrying one electrode, which screws into the metal of the cylinder, and the cone composed of mica, through which runs the other terminal, the two being joined together by screw connections as shown. The superior advantages of mica insulation, as claimed by the manufacturers, are that heat has no effect whatever upon it; thus rendering it much more durable than a plug made of porcelain or other substance liable to be affected by heat and allow short-circuiting of the sparking current.

current in the magnetic coil—which is superimposed on and occasioned by the battery current—to continue the flow of current in spite of the break in the circuit. The spark device shown in an accompanying figure is typical. As there shown, there are two electrodes, *X* and *Y*, the latter of which is set in an insulating plug, which is screwed into the wall of the combustion space, electrical connection being made by the wire shown at *D*. The other electrode, *X*, is here represented as a rotating spindle, deriving its motion from the link and small crank shown at *E*. and

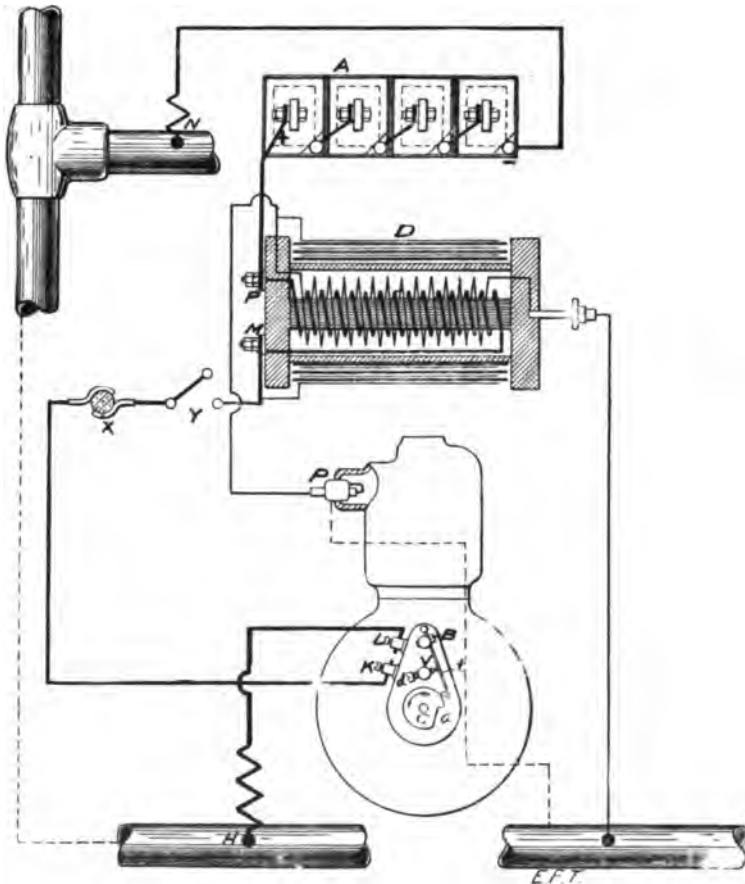

FIG. 332.—Diagram of the De Dion Jump-Spark Ignition Circuit. A is a battery of four cells, one pole of which is connected, as shown, to the tubular frame of the carriage at the point, N, the circuit being thus completed through the steel frame work to binding post, L, on the circuit breaker: thus, the circuit is made by the contact of the trembler, T, with the point of the screw, D, on the post, V, through binding post, K to M, thus through the primary winding of the induction coil and to the opposite pole of the battery. The secondary circuit joined to one pole of the condenser, D, is connected to one end of the sparking plug, P, the other, being grounded to the frame, completes the circuit by the metallic contacts with the body of the motor, as indicated by the dotted line.

forming the other terminal of the circuit, through the wire connected to the nut, *M*. On the end of the terminal, *Y*, is a resilient spring of platinum, which forms a contact with the electrode, *X*, and enables a spark to be formed whenever the contact is broken by its rotation. This method of periodically breaking the contact is so varied in several types of gas engine that the simple make and break device, positively operated, is substituted for the wiping contact of the rotating electrode. The advantages of the wiping contact are that the surfaces of the electrodes are constantly wiped clean of any impurities produced by the combustion of the fuel charge in the cylinder. It has, however, an even greater disadvantage involved in the enormous wear of the small points due to constant friction. The simpler make and break device, on the other hand, while producing quite as good a spark, permits no really reliable method of preventing the deposit of carbonized particles, which weaken and eventually choke the spark. The spark coil used with this method of ignition consists of a long core wound with a considerable length of low-resistance copper wire; the length of the core and the number of turns of the insulated winding determining the efficiency of the coil. Among the best known makes of American gasoline carriages using the primary spark may be mentioned the Duryea and Haynes-Apperson.

Properties of the Jump-Spark.—With the jump-spark produced from a secondary circuit, there are no movements of the electrodes, the primary circuit being periodically broken by a positively operated circuit-breaker, which thus produces an intermittent current of varying intensity in the secondary. The electrodes are usually contained in a device known as a sparking-plug, in which they are perfectly insulated from one another, by the use of lava, porcelain, mica or other suitable substance; the lava or mica insulation being generally considered the most serviceable. The most common objection to the use of the jump-spark is found in the fact that particles of carbon dust, produced by the combustion of the fuel charge, are apt to be deposited between the small contact points of the electrodes, thus preventing the formation of a spark, by filling up the break in the circuit. Various constructions have been adopted for increasing the efficiency of the jump-spark, most of them embodying the theory

that an electrical discharge takes place most readily and with greater effect in the line of producing an extensive and powerful spark, when a finely pointed terminal, carrying a current of high

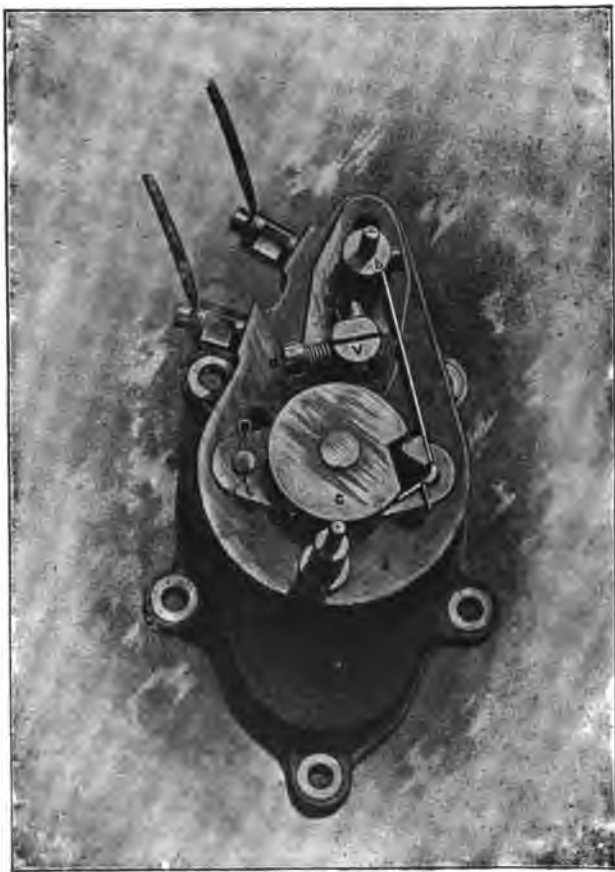

FIG. 333.—The De Dion Circuit Breaker. The parts lettered are the same as those indicated in Fig. 332.

potential, is approached to a cylindrical, semi-circular or plain surface connected to the ground. For this reason some of the most highly recommended sparking-plugs, instead of having two finely pointed electrodes, separated by such a small distance as

from 1-32 to 1-16 inch, have one such finely pointed terminal, opposed to a cylindrical or conical surface, of considerably larger dimensions. It is also claimed that such a construction reduces the danger of carbon deposits, from the fact that the electrical energy is dispersed through a much more extended area.

The De Dion & Bouton Jump-Spark Circuit.—Very nearly the typical arrangement for the high-tension jump-spark circuit is that used on the De Dion & Bouton carriages. The general plan of the connections is shown in an accompanying diagram, where, as may be seen, the current produced by a chemical battery is passed through the primary winding of the induction coil,



FIG. 334.—A Typical Jump-Spark Circuit Induction Coil—the “American” Double Terminal Coil. This coil, which is one of the most effective in use, has a double wound secondary with sparking contacts for two jump-spark plugs. According to the manufacturers, where two plugs are required to spark simultaneously, the best results are obtained by using a coil with two secondary windings and three secondary lead wires, one of which is grounded, and one carried to each of the plugs. The circuit thus formed gives, according to claims, the strongest possible effect in gas engine ignition.

the circuit being periodically broken by a vibrating trembler or contact breaker, the details of which are also given. The primary battery consists of several “open-circuit” dry cells of ordinary description, connected in series, the combination approximating five volts. The general connections of the primary circuit, as shown in the diagram, are as follows: the positive or carbon pole is connected to the primary winding of the induction coil, the opposite terminal of which is connected to the lower of the two binding screws attached to the vulcanite base of the contact breaker. The negative or zinc pole of the battery is connected to ground, as shown in the diagram, by contact with

the metal of the motor cylinder, the circuit being completed by a wire connecting with the upper binding post on the contact breaker. The operation of this contact breaker is obvious. It consists of a positively operated cam, *C*, which is of round contour except for an irregular sector-shaped notch in its circumference, which allows the point of the trembler, *T*, to drop at a certain point of its rotation, thus making contact with the trembler spring, which is connected, through the terminal, *B*, and the upper binding post on the base of the apparatus, with

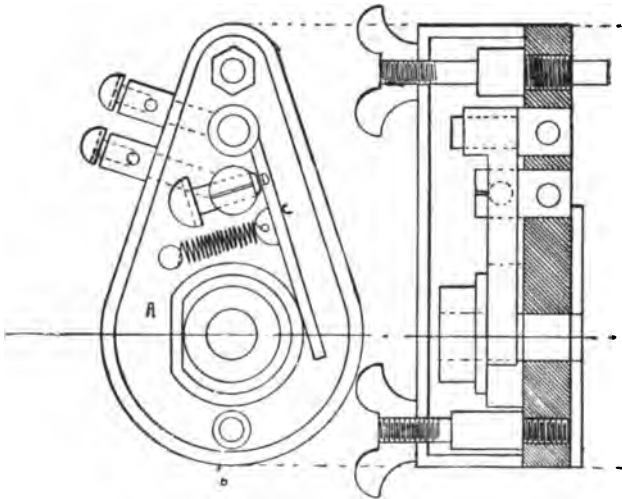

FIG. 335.--The "Dyke" Contact Breaker, shown in plan and part vertical section. Unlike the De Dion contact breaker, the cam, *A*, has no notch, but is flattened at one point on its circumference, so that the trembler spring, *C*, is periodically brought into contact with the other terminal of the circuit with the minimum of wear and shock. The advantages claimed for this device are consequent superior durability and quite as good effect in making and breaking primary circuit.

the negative pole of the battery, and the screw, *d*, which is connected through the lower binding post with the positive pole of the battery, as already explained. By this means, the circuit being periodically broken, a powerful high-tension current is produced in the secondary winding of the induction coil, one terminal of which is connected with the insulated portion of the sparking plug, the other with the metal of the cylinder; the spark being produced between the terminal contacts of the plug at every interruption of the primary current. By this arrange-

ment of the circuit, as has been asserted, the electrical potential of the secondary circuit, and therefore of the grounded point of the sparking plug, are reduced to the lowest value, the negative terminal of the battery affording a constant dead ground at a

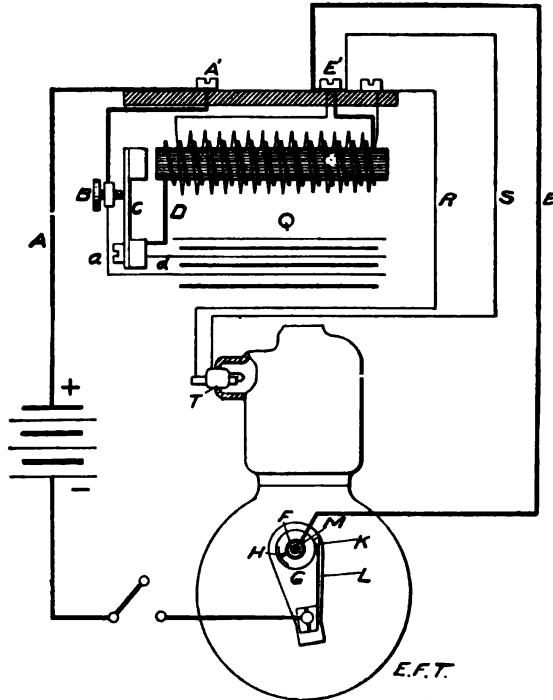

FIG. 336.—The Benz Jump-Spark Circuit. Unlike the De Dion system just described, both the primary and secondary circuits are carried by visible leads, no part of either being grounded to the frame. The circuit emerging from the positive pole of the battery passes through wire, A, to binding post, A' on the coil, to one contact at B of the trembler, C, thence through C and D to the primary winding of the coil; then through a and d through the condenser, Q. The other terminal of the primary winding emerges from binding post, E', passing over lead wire, E, to sleeve, M, of the rotary cam, G. The sleeve, M, is in electrical contact with the metallic section, H, on the circumference of the cam, being turned on the spindle, F, so as to periodically make contact with the head, K, of the trembler spring, L. The secondary circuit is completed through lead wires, R and S, to the two terminals of the plug, T.

much lower potential than may even be found in the metal base of the machine as a whole. On the closing of the primary circuit through the contact spring, as already described, the current of the primary winding of the induction coil rises rapidly

to its full value against the opposing self-induced current generated in the coil and establishing a powerful magnetic field, whose lines of force intersect the plane of the convolutions in the secondary circuit, creating therein, during the brief period when the battery current is flowing, a constantly increasing difference of electrical pressure between the grounded secondary terminal and the opposed extremity of the same winding. The difference of electrical pressure, resulting from the increasing density of the magnetic field, is not great enough, however, to cause a spark discharge between the sparking points of the plug, owing to the fact that the range of change in the density of the magnetic field is retarded by the self-induction of the primary circuit opposing the rapid flow of the battery current. A condenser is therefore used, one pole of which is connected to the primary terminal, wired to the lower binding post of the contact breaker and thus to the screw, *D*, already mentioned, the other being connected to the grounded terminal of the secondary circuit. By this means the magnetic field produced in the primary winding of the coil is almost instantly destroyed whenever the battery circuit is broken. Thus, it is possible to obtain a high speed rate in alternately making and breaking the primary circuit, while at the same time maintaining a secondary current of sufficient potential to produce a powerful spark without interference from the self-induced current produced in the primary winding of the coil. The action of the condenser in this system is well expressed in the words of a noted authority as "a heaping up of electrical pressure at the end of the wire of the primary circuit, to which it is attached," and this finding no outlet, the wave of electrical pressure sweeps back through the primary coil and instantly demagnetizes the core, owing to the fact that its flow is in the reverse direction to that of the original self-induced current. This effect is produced with great rapidity, and is a large factor in rendering the De Dion system one of the simplest by which a high-tension current may be generated for ignition purposes in an explosive motor. Among the objections to the system may be mentioned the fact that a large primary current is required in proportion to the useful work accomplished, which contributes to the end of speedily exhausting the battery. Among other objections may be mentioned the high speed at which the breaks of current must be effected, with the result of

soon wearing out the best made spring that could be used on a contact breaker.

The Benz Jump-Spark Circuit.—The constructional and operative objections involved in the De Dion system of ignition are largely overcome in the Benz secondary ignition circuit, which embodies many of the features most often used with modern gasoline engines employing this method of ignition. As used on the Benz carriages, the primary circuit is supplied by storage cells instead of primary batteries, the average current used being from $1\frac{1}{2}$ to 2 amperes, at four volts, for twenty to twenty-five working hours. As is obvious, however, the use of storage batteries is by no means an essential feature of the

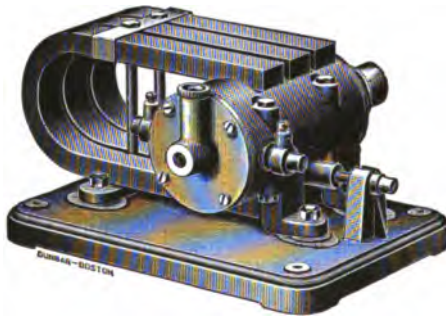

Fig. 337.—Holtzer-Cabot Horizontal Magneto-Generator, used in the sparking circuits of gas engines. This machine is built on the same plan as the vertical magneto shown in Fig. 336, but to meet the requirements of many motor vehicle engines, is mounted as shown, in order to be more readily adopted to a limited space.

system, their adoption by Benz indicating only a method of escaping inconveniences involved in the use of common types of primary cells. Instead of the notched cam and trembler spring used on the De Dion carriages, for periodically breaking the circuit, a leaf spring, carrying a contact button at its free point, bears against the circumference of a rotating vulcanite disc, which through a small arc carries a brass plate electrically connected to the spindle of the rotating disc. To this spindle is connected one terminal of the induction coil primary. The spring bearing upon the periphery of the rotating disc is connected direct to the negative pole of the battery. By this means, whenever the brass plate on the disc comes in contact with the button

carried at the extremity of the spring, the primary circuit is made.

The induction coil used with this ignition system is of the usual construction, except that it has a magnetically operated contact breaker, which serves to break the primary circuit as soon as the core has acquired its full magnetic properties. The current, emerging from the positive pole of the battery, moves along wire, *A*, to binding-post, *A'*, and thence to the screw *B*, which is normally in contact with spring, *C*, of the contact

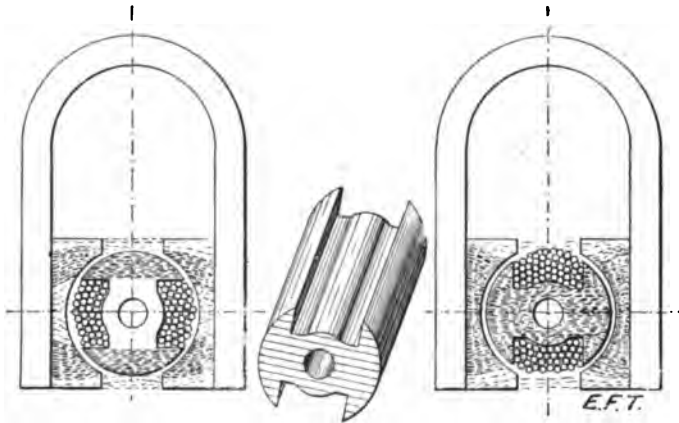

FIG. 338.—Diagram of the Construction and Theoretical Operation of a Typical Magneto-generator. Between the prongs of the horseshoe magnets, the shuttle-shaped armature is wound from end to end with insulated wire, so that when rotated a powerful current is produced in the windings by cutting the magnetic lines, whose varying strength is shown by the shaded portions in the two views. When the armature is in the position shown in the first diagram, the lines of force mostly converge at the top and bottom, finding a direct path through the metal end flanges of the shuttle. When in the position shown in the second diagram, the lines are converged so as to pass through the metallic core of the armature; the most direct path being chosen in both cases.

breaker. Moving thence through the spring, it emerges on wire, *D*, moving thence through the primary winding of the induction coil to binding-post, *E'*, and wire, *E*, which is in electrical contact with the spindle, *F*, of the rotating disc, *G*, the circuit being closed, as already stated, whenever the brass arc, *H*, on the periphery of the disc is brought into contact with the button, *K*, carried on the spring, *L*. The point of ignition may be timed by modifying the relative positions of the contact piece, *H*, and the button, *K*; this act being accomplished by loosening the ad-

justment screw and turning the disc, *G*, on the spindle, *F*, to the required point. The metal sleeve, *M*, in contact with the spindle, *F*, maintains the electrical contact between, *H* and *F*, and thus with the wire, *E*, no matter what may be the degree at which the contact, *H*, is shifted. The spindle, *F*, being a secondary shaft, rotates so long as the engine is in motion, thus making the primary circuit once in every two revolutions of the fly-wheel.

The two terminals, *B* and *C*, of the wires, *A* and *D*, are connected as shown by the wires, *a* and *d*, with the condenser, *Q*, which consists of a number of layers of tinfoil and paraffined

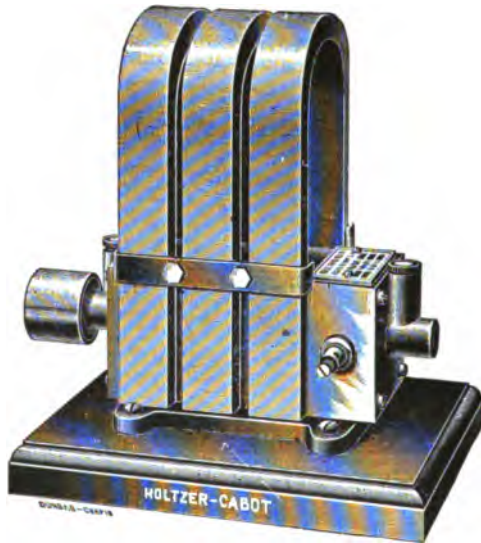

FIG. 389.—A Typical Magneto Generator—the Holtzer-Cabot Vertical Standard. The machine here shown is similar in all its details to the former, but is built in larger proportions and gives a more powerful output in E. M. F.

paper disposed beneath the coil, the object being, as with the De Dion system, “to suppress the spark discharge of the primary self-induced current, which otherwise would take place on the break of circuit, and to increase the rate of demagnetization of the core.”

As may be readily understood, the primary circuit has scarcely been made before the iron head of the contact breaker, carried on the spring, *C*, is attracted to the core of the induction coil,

thus momentarily stopping the flow of current. Its vibrations, however, are of such rapidity that, judging from the pitch of the note sounded by it when in operation, they average at least four complete breaks during the brief period in which the brass piece, *H*, on disc, *G*, and the button, *K*, on spring, *L*, are in contact. The result of these rapid fluctuations of the magnetic field is a continuous stream of hot, flaming sparks between the points of the plug, during the period in which the primary circuit is made, the number of impulses of the secondary current on the wires,



FIG. 340.—The American "Little Giant" Ignition Magneto. This generator consists of six magnets placed end to end as shown. An armature of the ordinary dynamo pattern, rotates within the pole pieces, generating a powerful current at any speed between 800 and 1,500 revolutions per minute, and developing between 10 and 15 volts and from 6 to 8 amperes. By a combination of permanent magnets and field windings, the field is constantly maintained, while the spark produced is the most powerful that could be generated by any machine of its size and weight.

R and *S*, to the two terminals of the sparking plug, *T*, being greatly increased.

The Sources of Current: The Magneto-Generator.—The general plan with electrical ignition circuits, producing a spark from a secondary current, is to use some form of chemical battery, preferably of the dry-cell, open-circuit variety, as the source of energy. Such chemical cells are necessarily of the

open-circuit variety, since it would not be practicable to periodically interrupt the current from a closed circuit cell without using much more complicated machinery, and wasting an immense percentage of the total output. There are numerous open-circuit dry cells that are suitable for use in connection with the ignition circuits of gasoline vehicles; but it is not necessary to dwell upon their construction and properties, since the sole requirements seem to be reasonable durability and an average output capacity: such cells, averaging from 1 to $1\frac{1}{2}$ volts, are connected in batteries of three or four, so as to be capable of pro-

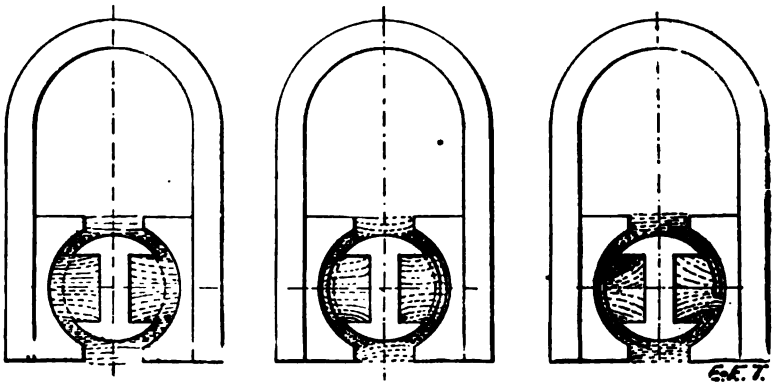

FIG. 341.—Diagram of the Construction and Operation of the Sims-Bosch Igniting Magneto. In this machine the armature is stationary, the lines being cut by an open sleeve rotating between it and the field pieces. The first diagram shows the convergence of the lines of force before the rotating sleeve has been inserted; the second shows the lines when the sleeve is directly across the magnetic lines; the third, where the sleeve is in position at oblique angles to the lines. As may be understood, this arrangement produces a very powerful variation of the field and a very strong output of E. M. F.

ducing a current of from $1\frac{1}{2}$ to $3\frac{1}{2}$ amperes, the average for gasoline carriages.

With gasoline vehicles using a primary sparking circuit, the source of electrical energy is practically always some form of small dynamo or magneto-generator. The primary distinction between these two forms of electrical source, as the words are generally used, is that the magneto-generator has a permanent magnetic field, being composed of several permanent magnets, between the poles of which the lines of force are regularly cut by a rotating armature. The word dynamo, on the other hand, is commonly used to designate the mechanical source of elec-

trical energy, having a separately excited magnetic field, generally consisting of an even number of pole pieces or cores, each of which is wound with a suitable length of insulated wire, connected in series to another length of opposed polarity throughout the entire length of the field. Between these pole pieces rotates an armature composed of a suitable drum or bar, wound about with a suitable length of insulated wire, the two terminals of which connect through the commutator to the outside circuit, which begins and ends at the commutator brushes.

The Construction of Magneto-Generators.—The commonest form of magneto-generator consists of two or more horse-shoe magnets set in suitable pole pieces, between which rotates a shuttle-shaped armature wound about with a suitable length of fine insulated wire. As may be seen in the accompanying illustration, the lines of force extending between the poles of these magnets are variously distributed according to the point occupied by the armature in its rotation. It may thus be understood that any movement of the armature on its spindle, either in making a complete revolution or in oscillating backward and forward, must operate to deflect and distort these lines of force in such a manner as to set up powerful induced currents in the armature winding. Since, however, the paths of the magnetic forces are thus continually shifted from the lines of the least resistance to the lines of the greatest resistance, it follows that the current delivered from the terminal connections will have a constantly shifting potential, and will hence be an alternating current—that is to say, a current flowing first in one direction and then in another. This is the very thing that is required in telephone circuits, for which magneto-generators are commonly used, to produce a current for operating the switchboard drops and transmitting call-bell signals. For this purpose, one end of the armature winding is connected to the centre of the rotating spindle, which is insulated; the other to the frame of the machine. Generators of precisely similar construction and wiring may be used for gas-engine ignition, provided the cut-off of the current be timed to occur at precisely the point of highest potential or greatest intensity, which is to say, when the longitudinal flange pieces of the shuttle-shaped armature are in a vertical position. For ordinary ignition circuits, however, the alternating

current is not used, and consequently the magneto is equipped with a rotating commutator and terminal brushes, such as are used on direct-current dynamos.

The Operation of a Magneto-Generator.—The general operation of the magneto-generators depends upon a few obvious principles of construction, which we may sum up under the following heads: 1. The quantity of the current depends upon the strength of the magnetic field and the number of lines of force passing through the armature. 2. The electromotive force produced depends for its amount upon the length of the armature



FIG. 342.—A Typical Ignition Dynamo—the Apple Dynamo Igniter. This shows the interior of the machine, the cover at the rear of the case being opened. The parts shown are the winding of one pole, the commutator brushes, the spider supporting the rotating spindle of the armature, and the wick-feed oil cup for lubricating the bearing of the spindle.

winding, and the rapidity with which the armature is rotated, cutting and deflecting the lines of magnetic force. If the armature be wound with comparatively thick wire, which would give a short winding, the E. M. F. will be low; but if it be wound with a finer wire, giving a much greater length, the E. M. F. will be higher in ratio to the diameters of the wires used.

A Stationary Armature Magneto-Generator.—Although most of the magneto-generators manufactured for use in igniting gas engines conform to the general characteristics of the ma-

chines just described, an interesting variation is found in the Bosch & Simms stationary armature generator, which operates without a commutator, the terminals being connected to the outside circuit, as in the ordinary telephone magneto. The armature of this machine is of the shuttle-shaped pattern, wound with insulated wire as already described, but it is fixed rigid at one end in such position that the lines of magnetic force strike directly through the insulated coil of the winding. The armature, however, is of somewhat smaller relative diameter than is used on the other types of magnetos, in order to leave a clearance for

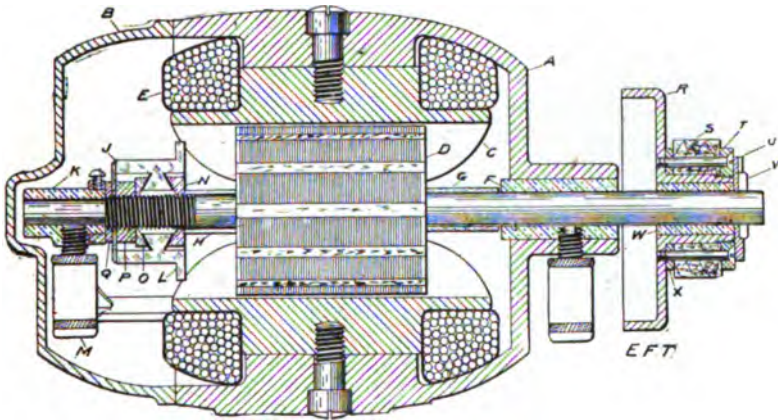

FIG. 343.—Sectional Diagram of the Apple Igniting Dynamo. The parts shown are: A, cast iron body containing the moving parts; B, the hinged lid of the body; C, the one-pole piece of the field magnets; D, the armature; E, the coil of one of the field magnets; F, brass bearing of the armature spindle; G and H, fibre tubes surrounding the spindle; K, brass spider supporting the spindle; L, commutator; M, wick feed oil cup; N, beveled nut supporting the commutator; O, P, Q, supports of the commutator; R, the driving disc; S, lever friction pinion.

an intervening sleeve or open-sided cylinder of soft iron to be oscillated on the same axis between it and the pole pieces. This sleeve is caused to oscillate through about one-half a revolution by the connecting rod and crank geared to an adjustable cam on the secondary shaft of the engine, the difference in throw between the crank geared to the spindle of the sleeve and the radius of the cam operating to prevent a full revolution. This cam also operates to break the circuit at the contact points within the cylinder, at a predetermined point in the stroke, which is always made to occur at precisely the point when the oscillating

sleeve is in position to cut through the greatest number of magnetic lines, thus producing the maximum E. M. F. The spark may be advanced by a feather on the cam, and a spiral groove cut on its spindle, so that when it is moved lengthwise the operation of the contact breaker may be varied, although maintaining the sparking point at the same maximum position of the oscillated sleeve.

The Ignition Circuit of the Simms Magneto.—The ignition circuit arrangements used in connection with this form of gen-

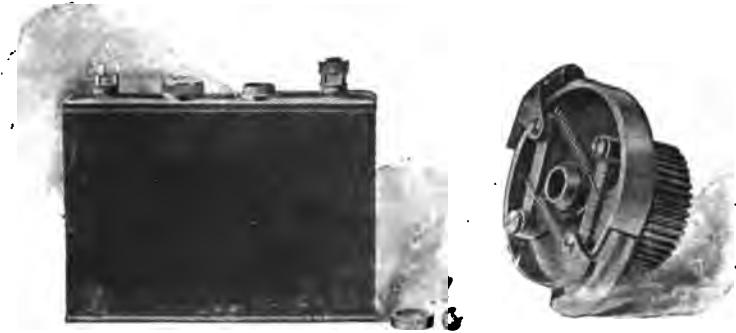

FIG. 344.

FIG. 345.

FIG. 344.—Apple Storage Battery, used as starter in the ignition of the Apple dynamo. This is a two-cell battery of excellent construction, having a capacity of 4 volts. As shown in the circuit diagrams in Figs. 329 and 346, it may be used either with or without the dynamo, or simply for starting the engine, until the latter has taken up its speed.

FIG. 345.—Centrifugal Governor, used on the Apple Dynamo for modifying the speed within required limits. The centrifugal weights of this governor are contact shoes, which normally bear upon the circumference of the pulley. When the speed has exceeded a predetermined limit the weights fly outward as far as the adjustable springs will permit, thus disconnecting the spindle attached to the pulley from the main shaft rotated by the spur wheel, and keeping the rotation of the armature at the required speed.

erator are the simplest possible, although its sparking efficiency is very high. The positive terminal is on an insulated binding screw at the top of the armature, the path of the return current being through the metal of the engine cylinder, to the base of the magneto-generator. In general, the method adopted for driving the rotating portion of the magneto is to connect it direct to the fly-wheel of the engine, either by a belt or a brushing roller. With this arrangement it has usually been found that a current sufficient to begin sparking may be produced by the act of turning over the fly-wheel to start the motor. Several manu-

facturers, however, include a battery of galvanic cells in the ignition system, so as to supply the required strength of current at the first break between the sparking contacts. This battery is cut out of circuit as soon as the current from the magneto is thrown in by means of an electro-magnet in the circuit, which attracts its armature and breaks the connections of the chemical battery.

The use of a magneto-generator as a constant source of current involves but one objection, which is that the permanent magnets will gradually lose their magnetism, with the result that the strength of the current produced will constantly decrease, although with magnets made of suitable steel and fully mag-

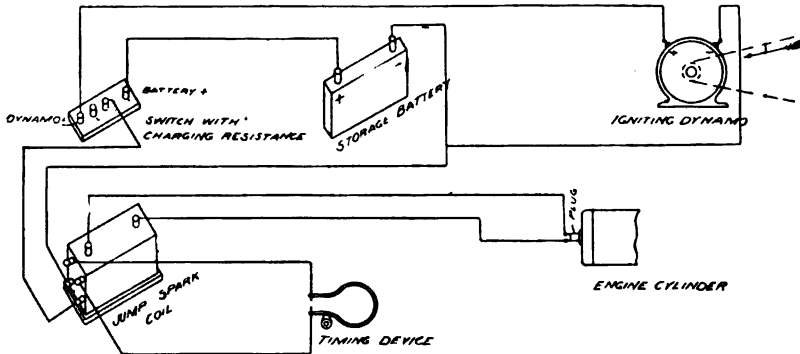

FIG. 346.—Ignition Circuit, containing a Dynamo Generator and Storage Battery. Both terminals of the secondary winding of the induction coil have visible leads to the sparking plug. An adjustable vibrator on the coil enables the timing of the spark. As in Fig. 320, the storage battery furnishes current for sparking until the dynamo has taken up its speed, and may then be cut out of circuit, as desired.

netized this event may be very long deferred. In order to delay it as far as possible, and at the same time obtain a current carried at the maximum pressure, one American manufacturer has produced magneto-generators in which the entire length of the magnets above the pole pieces is wound with a continuous length of insulated wire, this coil being connected in series in the circuit with the terminal brushes on the commutator. As has been claimed, the current traversing the coil acts to increase the degree of magnetism to the point of saturation, a large part of the effect being retained, with the result that the maximum of residual magnetism is supported and re-enforced when the ma-

chine is in operation. At the same time the core winding in such a generator performs the double duty of increasing the intensity of the magnetic field, and, by its self-induction, adding to the intensity of the spark, without seriously affecting the magnetism at the moment of break, which result would certainly follow with the use of a series wound dynamo with separately excited field.

A Typical Ignition Dynamo.—One of the best known American-made dynamos for supplying the current for a gas-engine ignition circuit is the Apple generator, the details of which are shown in several accompanying illustrations. This is a small two-pole, constant-current dynamo, giving about 8 volts at between 1,000 and 1,200 revolutions. The armature coil is laminated after the most approved style in large power dynamos, being composed of a number of thin-toothed discs, punched from charcoal iron and hung on a shaft of one-half inch diameter. The armature winding is so effectually insulated that the machine is positively guaranteed against ground or short circuiting. The commutator is insulated throughout with mica, and the arrangement of the brushes is such that the commutator shaft may be rotated in either direction without injury. The brushes themselves are built up of fine copper gauze, between the folds of which is inclosed a carbon preparation, which at once prevents ragging out and cutting the commutator, and also furnishes a desirable lubricating element. The bearings of the armature shaft are lubricated by wick cups, the wick being held against the shaft by a suitable spring, which insures the necessary lubrication without danger of flooding. One of the most excellent features of this generator is the simple centrifugal governor which acts to maintain the speed within the proper limits by interrupting the driving connections, which may be by belt, gear wheels or simple friction, thus preventing burning out of the fields, which would certainly occur should the speed be maintained at too high a rate. By the use of this device for maintaining a constant speed of armature rotation, independent of the speed of the engine, the ratio may be so adjusted that a fly-wheel, capable of an average good speed at starting, the generation of current may be begun without the use of a separate starting or igniting source.

CHAPTER THIRTY-ONE.

TRANSMISSION GEARS AND SPEED-CHANGING DEVICES FOR GASOLINE VEHICLES.

Speed-Changing Devices for Motor Carriages.—A gasoline motor carriage, like a machine-shop plant, is necessarily equipped with some kind of a mechanical geared device for changing the ratio of speed and power between the motor and the running mechanism. The principle upon which the typical speed-changing devices depend is well illustrated by the familiar cone or stepped pulleys, such as are used on lathes and some other mechanical contrivances. In such a device as this, the desired change of ratio of speed and power is obtained by shifting the belt in a direction lengthwise of the shaft, which act enables the variation of the speed by connecting a pulley of small diameter on the main shaft with one of large diameter on the secondary shaft, for example, or when the opposite effect is required, connecting a large pulley on the main shaft to a small one on the secondary, the total length of belt, of course, always being the same. It is perfectly possible to obtain the same effect of variation by belting together two pulleys of simple conical contour, their apexes being disposed in opposite directions. The effect of increasing speed with such devices means, of course, a dissipation of a considerable part of the available power, while on the other hand a decrease of speed at the driving end involves a larger percentage of available power.

Speed-Changing Gears and Engine Throttling.—A speed-changing mechanism of some description is necessarily used on vehicles propelled by gasoline motors, principally because it is less difficult to shift a mechanical gearing than to properly throttle the charge, which is the only really practical method of varying the speed of the piston. With explosive motors, operating with an automatic governor of any description, and having no provision for throttling by hand, a speed-changing gear is a positive necessity, on account of the fact that, with a properly proportioned fuel mixture, the speed is maintained at a practically

constant rate. As a matter of fact, the mechanical speed-changing devices were first adopted in carriages propelled by automatically governed engines, but since the greater perfection of certain details has made possible a reliable throttling connection, they are in general far less complicated and somewhat less important. There are two purposes, however, for which a changing gear of some description must always be included; the one is for reversing the travel of the carriage, the other for securing a proper proportion of available power for hill-climbing. With

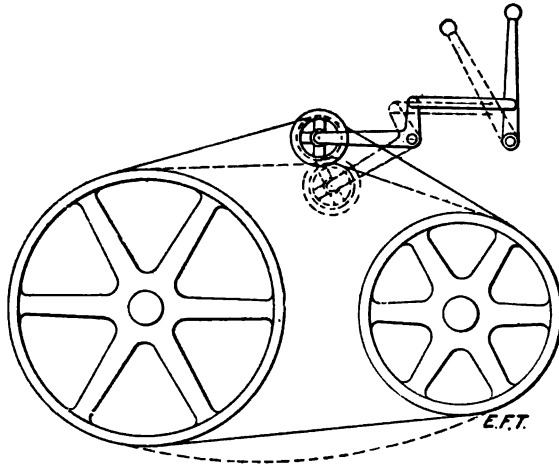

FIG. 347.—Diagram of the Belt Transmission, used on the early Daimler carriages. As shown in the cut, two pulleys of different diameters—any diameter ratios may be used—are connected by a belt. This belt is normally loose, but may be tightened by a jockey pulley mounted on one arm of a bell crank lever, so as to tighten or loosen the belt, according to the position given it by the hand lever, as indicated by the full and dotted lines.

a steam engine, as we have seen, the best results may be achieved by reversing the movement of the engine, and, secondly, by delaying the point of cut-off so as to admit more steam at each stroke and depend less upon its expansive action. But a gas engine may not be reversed and its available power pressure may not be increased beyond a certain definite limit.

The Daimler Belt and Pulley Transmission.—Very nearly the simplest practical device ever employed for shifting the speed and power ratios was the belt transmission, used with some of

the earlier Daimler carriages. Briefly described, it consisted of four pulleys regularly increasing in size, keyed to the main shaft, and four others regularly decreasing in size in the same order, keyed to the countershaft. Four belts

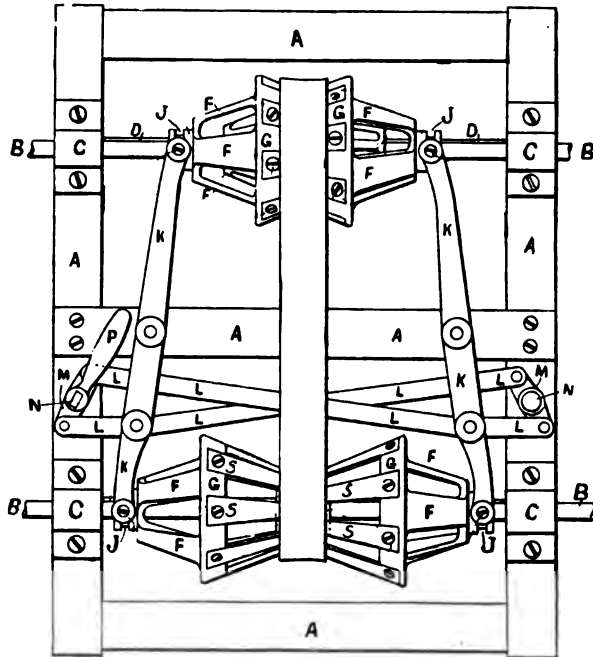

FIG. 348.—Diagram of a Variable Cone Pulley Transmission, by which the relative speeds of the driving shaft and counter shaft may be varied by changing the diameters of the driving and driven pulleys. In this figure, A is a frame on which are mounted the two shafts, B and B', turning in the bearings, C and C'. On each of these shafts is a feather, D, on which slide double cones, F, F, F, F. To the apex, J, of each of these cones, are attached fingers, S, S, S, S, which are screwed to the heads, G, G, G, G, as shown. A handle, P, pivoted at N, may be turned in either direction, actuating the levers, L, L, L, L and K, K, K, K; thus modifying the belted diameter of either pulley from that shown in the upper of the two to that shown in the lower one. Thus the speed ratios in the two may be varied to any desired point. The levers, K, K, K, K, by forked connections, actuate the cones, causing them to slide along the feathers, D, D, D, D, at the spools, J, J, J, J. The device shown in this illustration is the subject of an American patent; but similarly arranged and operated cone pulleys have been employed on the Foulliarion carriage and others.

connected these eight pulleys, and the power was thrown into any one pair as desired, by tightening the belt with an idler pulley mounted on a suitably disposed bell crank. By this method it was possible to obtain four speeds forward on

an even roadway, or to vary the power to suit the requirements of various ascending grades. There was no provision, however, for reversing the movement, the only method of turning the carriage in a short radius being to bring the centre pivoted front axle all the way around, so that the small forward wheel cut under the body, as in a horse-drawn vehicle. It would be perfectly possible, however, to obtain a reverse motion by such a belt transmission as this, by simply crossing one of the belts in the manner frequently seen in stationary power plants of all descriptions, although it is doubtful if a cross belt, unless of unusual length, could be tightened with an idler pulley as with others. A loose pulley on both shafts of a belt-shifter would seem to furnish the only really practical means of manipulating a reverse movement of such a description. The method of using fast and loose pulleys and shifting belts has been successfully applied in several types of motor carriage, among which may be mentioned some of the light Benz carriages made in Germany, and one or two of the carriages manufactured by the English Daimler Motor Co. In both these instances, however, the shafts are arranged at a sufficient distance between centres to enable an easy shifting of the belts.

Stepped Cone Pulley Transmissions.—Among the few examples in which step pulley shafts have been used for transmission and speed changing in a motor carriage, may be mentioned the Darracq-Bollee machine, widely used in France. In this case the belt is shifted on oppositely tapered pulley cones, by means of an ordinary shifter, by which means five speeds forward can be readily obtained, without the jar and friction experienced with some other types of speed gear. The reverse gear used with this carriage was of a highly effective and ingenious description for the method of transmission. The stepped or cone pulley on the main shaft turned on a sleeve, which was made rigid with the fly-wheel for forward movement, by interlocking of a spur pinion screwed to the end of the sleeve, an internal gear upon the circumference of the fly-wheel and the idler pinion meshing with both. In forward driving this idler pinion was rigidly clutched, so that it could not rotate on its own axis. When, however, the motion of the carriage was to be reversed, the clutch was thrown out by a special lever coming to the driver's hand,

and the idler pulley, then rotating on its own axis, transmitted the motion from the internal gear in the reverse direction, to the spur pinion on the end of the rotating sleeve carrying the stepped pulley.

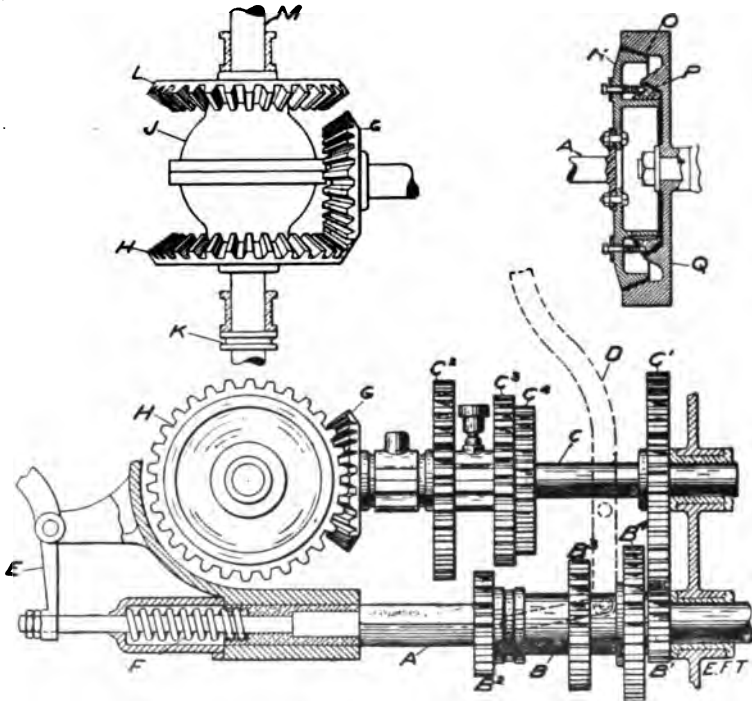

FIG. 349.—Details of the Panhard-Levassor Change Speed Gear. A is a square section of the main driving shaft connected to the motor by the cone clutch shown in the right hand upper diagram of the figure. B is a sleeve caused to slide on A by means of lever, D, which carries four spur pinions, B¹, B², B³, B⁴, which are of such diameter as to match respectively with pinions, C¹, C², C³, C⁴, keyed on the counter shaft, C. The motion being imparted from the main shaft, A, through sleeve, B, through any one pair of pinions to the shaft, C, causes the rotation of the bevel pinion, G, which, as shown in the left-hand upper diagram of the figure, may mesh with either bevel gear, H or L, which are secured to a sleeve sliding on a feather on shaft, M. At K is shown the spool to which is connected the fork of the shifting lever, the object being to alter the direction of the motion according as H or L is in gear. J is a differential gear drum. The main clutch is thrown on or off by means of the lever, E, and is held in position by the spring, F. The construction of the clutch shown is as follows: On the end of the shaft, A, are mounted the double male cones, N and P. On the end of the crank shaft of the engine are the double female cones, O and Q. When under the force of the spring, F, the two cones adhere by friction contact, thus transmitting the motion of the crank shaft to the main shaft, A, by throwing out the clutch, the engine may continue moving without driving the carriage.

Speed-Changing by Shifting Gears.—At the present time belt transmission for motor carriages has been nearly, if not

entirely, abandoned in favor of spur gear or sprocket, so that the several devices for belt shifting or tightening have been necessarily superseded by interlocking or shifting spur wheels, or some combination of clutch and planetary gears. The typical method of shifting the speed and power with a spur wheel system is to have several spur wheels of as many different diameters, keyed to a countershaft, with the same number of spurs, whose diameters vary inversely, keyed to a sleeve, arranged to slide on a key on the main shaft or on a square section portion of the shaft. The latter construction is the most usual, as affording the most reliable method of holding the sleeve rigid and securing a proper transmission of power. The driving shaft, whose speed is varied according to the position of the gear-carrying sleeve, transmits the power to the drive wheels, either by sprocket or gear connection. In all transmission systems using shifting gears on the main shaft it is necessary to throw out the main clutch, before attempting the operation of shifting the speed, since to do otherwise would mean not only a very probable difficulty in effecting the desired connection, but also, in a great majority of cases, would involve very serious friction or complete stripping of both gears. In fact, this is the almost fatal objection to this method of speed changing, since all but the most experienced drivers will occasionally neglect to throw off the clutch. Under the most advantageous circumstances, and with the most careful handling, there is necessarily such a large amount of wear and friction that the gears must be periodically removed. For this reason a host of inventors have set themselves to the work of perfecting a method of speed changing which shall involve neither too much experience in the driver nor too much wear or shock consequent on moving from a lower to a higher speed. As must be obvious also, it is easier to change the gear from a low to a high speed than vice versa, since the attempt to throw on the low speed when the car has obtained some momentum must result in an uncomfortable jerk, if not in irreparable damage, when the shifting is carelessly performed.

The Panhard-Levassor Speed Gear.—One of the most representative and complicated change-speed mechanisms of the spur gear type is the modified Daimler transmission used on the Panhard-Levassor carriages. As shown in the accompanying

illustration, it consists of two spur shafts, *A* and *C*, the former carrying on its square portion the sleeve, *B*, upon which, as shown, are four spur gears of varying diameter. On the shaft, *C*, are also arranged four gears, whose diameters vary inversely with those on *A*. At the right hand extremity of the shaft, *A*, is carried the male cone of the main clutch, which, when held in gear by a pressure of the spring, *F*, enables the transmission of power direct from the crank to the shaft, *A*. The clutch may be thrown out by lever, *E*, which acts to pull the shaft, *A*, to the left, compressing the spring, *F*. The sleeve, *B*, may be shifted on the main shaft by a lever, *D*, which is connected as indicated. When, as in the cut, the gear, *B*¹, is meshed with the gear, *C*¹, the car will have its slowest speed forward, and the act of shifting the gears to the left from that position will raise the speed at a regularly increasing ratio; the meshing of *B*² and *C*², giving the second speed forward, and the other gears the next two increasing speeds. Similarly, also, in the act of shifting the sleeve from the extreme left position, when gear, *B*⁴, is meshed with gear, *C*⁴, there will be a similarly regular decrease of ratio in their speed. This is an exceedingly excellent feature of this device, which reduces the danger of stripping the gears to the lowest point with proper handling.

The method of transmitting the motion from shaft, *C*, is through the bevel gear, *G*, which, as shown in both sections of the cut, meshes with another bevel, *H*. This bevel, *H*, together with a similar bevel, *L*, on the case containing the differential gear, are keyed to the sleeve, *M*, which works over the centred shaft, at two extremities of which are the sprocket pinions for driving direct to each of the rear wheels. As long as the bevel, *G*, drives on *H*, as shown, the motion of the carriage is forward, at any speed determined by the relative position of the shifting gears on the two shafts, *B* and *C*. In order to reverse the motion of the carriage, the sleeve, *M*, is shifted upon the lever, acting on the thimble, *K*, so that *H* is pushed out of mesh with *G*, and *L* is thrown in. By this process, as is obvious although the rotation of *G* continues in the same direction, the movement imparted to *L* will be the reverse of that previously imparted to *H*. Another advantage involved in the device is that the reverse has the same number of speed and power combinations as the forward motion, thus providing for all possible

conditions of grade and road surfaces. It is also obvious that, by shifting the sleeve, *M*, a certain distance, the driving connections to the main shaft, through the differential, *J*, will be thrown off altogether. This is the operation necessarily preceding the throwing on of the brake, the drum of which is on the counter-shaft, just beyond the thimble, *H*. By simultaneously disconnecting the main clutch, by turning the lever, *E*, and compressing the spring, *F*, and disconnecting the driving connections from *G* to *H* or *L*, the act of shifting the gears on *B* and *C* may take place with the least possible danger of breakage.

The Daimler Reversing Device.—Although the change-speed gear just described is an exceedingly effective and readily-oper-

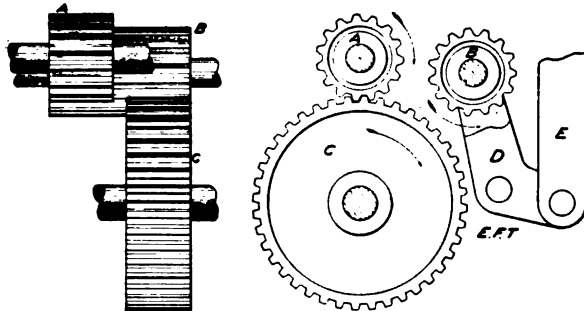

FIG. 350.—Details of the Reverse Gear used on the Daimler-Maybach Carriages. The change speed gear used on these carriages is identical with that used on the Panhard-Levassor, except for the bevel gear reversing arrangement. Instead of using this device, the pulley, *A*, on the main shaft, is thrown into gear with pulley, *C*, upon the second shaft, through the spur pinion, *B*, carried on the bell crank, *D*, and moved in or out of gear by lever, *E*. Thus the motion of *A* is transmitted to *C* in the reverse direction, although none of the gears on the first and second shafts may be in mesh.

ated mechanism, capable of producing the best results, both in carriage operation and the saving of breakage, as far as possible, the principal objection to be urged against it is the complication and consequent costliness. In order to eliminate one element of complication and possible uncertainty of action, the method of reversing is considerably modified in a precisely similar system of transmission, used on the carriages of the Canstadt-Daimler Co. Although their device resembled the one just described in having the shifting sleeve, *B*, on the main driving shaft, *A*, carrying spur gears intended to be meshed with others on shaft, *C*, which drove a bevel gear, *H*, through the bevel pinion, *G*,

there was no provision for shifting the sleeve, *M*, in order to throw in a bevel gear corresponding to *L*. The method of reverse was accomplished, briefly, as follows: the sleeve, *B*, was shifted to a neutral point, at which point none of its gears meshed with gears on *C*. In this position, as may be readily understood, at least one of the gears will be at a point just previous to meshing with its gear on *C*, although there is no contact whatever between them. At this point, which is indicated by the relative positions of gears *A* and *C*, in an accompanying illustration, the elongated idler pinion, *B*, in a fork on bell crank, *D*, is thrown into mesh with both *A* and *C*, by operating the lever, *E*. The effect of this act, as may be readily understood, is to transmit the motion of the driving pinion in the reversed direction to the driving shaft, with the result that the bevel gear, *G*, carried on the driven shaft, transmits its movement in a reversed direction. As may be seen, it is necessary to throw off the clutch, before throwing the idler into mesh with *A* and *C*.

Constantly Meshed Spur Gear Transmissions.—Although the method of shifting gears is an effective means of regulating the speed of a carriage, and next to the scheme of using loose pulleys or belt-tightening idlers, is also, as it seems, the simplest and readiest, a vast friction and wear following even the most careful handling, renders it exceedingly advisable that some means should be devised for having all the gears constantly in mesh, with one of every pair turning loose on its own shaft and being thrown in by some kind of clutching device, whenever it might be desirable to drive through it. A large number of combined clutch and gear transmissions have been placed upon the market, but since they all operate upon a few simple principles it is necessary to describe only one or two that seem typical.

The Montauban-Marchandier Speed Gear.—Among the most noteworthy transmissions of this general description may be mentioned the Marchandier, a sketch of which is shown in an accompanying illustration. Here, as may be seen, there are two shafts carrying spur gears, all of which are constantly in mesh. Four spur gears are keyed to the shaft, *A*, and four others turn loose on a sleeve over the shaft, *B*. The power is transmitted from the motor through the bevel gear, *C*, which is always in

mesh with two other bevels, *D* and *E*, which turn loose on shaft, *A*. By means of the shaft clutch, *F*, either one of these may be thrown into rigid relations with the shaft, *A*, thus insuring either a forward or a reverse transmission from bevel, *C*. In order that the motion may be transmitted to the countershaft, *B*, which carries a driving sprocket on either extremity, it is necessary that some one of the four loose turning pulleys carried on its sleeve be thrown into gear by the shifting of precisely similar shaft clutches. The operation of shifting these clutches on shaft,

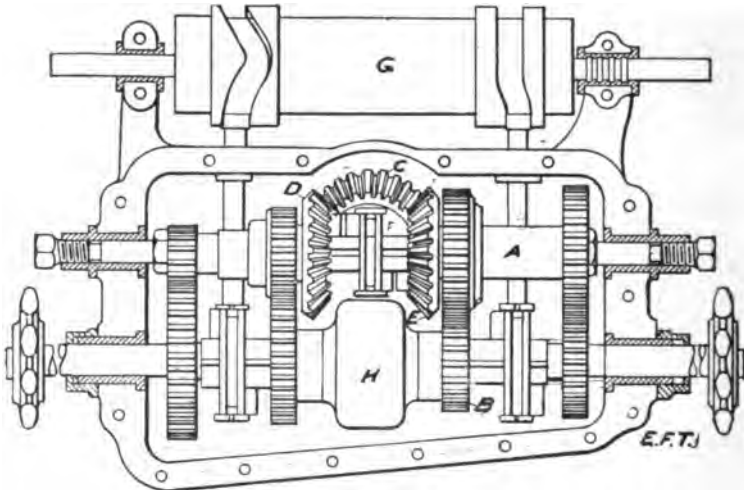

FIG. 351.—Details of the Montauban-Marchandier Change Speed Gear. *A* is the first motion shaft, to which are keyed four spurs of different diameters; *B*, the second motion shaft, carrying four loose spurs, capable of being engaged by clutches. *C* is a bevel on the drive shaft of the engine. *D* and *E* are bevels in mesh with *C* and capable of being tightened or loosened by the sliding shaft clutch, *F*, thus varying the direction of travel. *G* is a cam drum, by rotating which any desired spur on *B* may be clutched and thrown into gear with its mate on *A*.

B, is performed by means of a cam spindle, *G*, which carries on its surface two such cams as are shown in the illustration. The cams are so laid out that no two of the gears on *B* may be clutched at the same time, the proper connections for the desired speeds being, of course, indicated by notches on the quadrant of the shifting lever, or in some similar fashion. The power transmitted from *C* to *D* or *E* of the shaft *A* rotates the sleeve on shaft *B* through the spur that is held in gear by the cam-operated clutch. The rotation of the sleeve on *B* being thus accom-

plished, the shaft, *B*, and its sprocket pinions are driven in the desired direction, through the differential system at *H*. The advantages of this device are obvious, since it required no shifting of the gears whatever, and as all changes of speed and power ratio are controlled by a readily manipulated clutch mechanism.

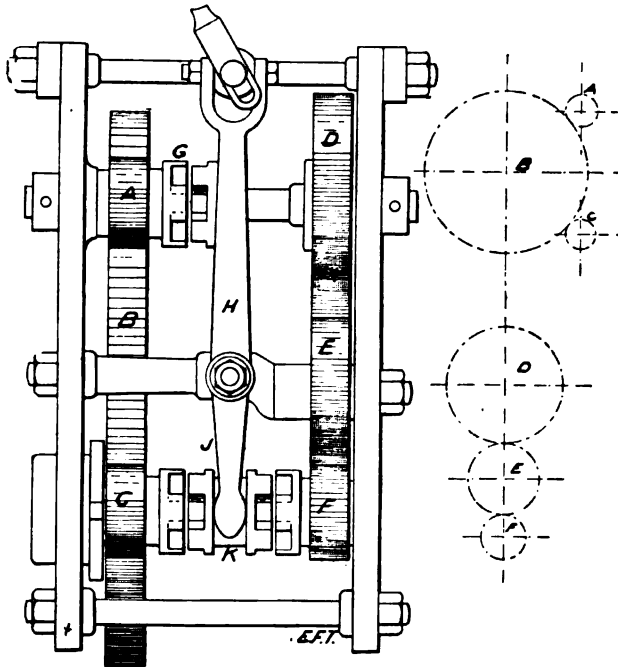

FIG. 352.—The Didier Two-speed Tricycle Gear. A rotating clutch pulley, *K*, slides on a feather on the main shaft, its position being shifted to the right or the left by the arm, *J*, of the lever, *H*, actuated by the handle as shown at the top of the figure. When it is moved to the left it engages the spur pinion, *C*, which meshes with the main drive gear, *B*, thus driving the cycle at the first or lowest speed. When it is moved to the right it engages the spur pinion, *F*, the rotating clutch, *G*, also engaging the pinion, *A*, on the second shaft, so that *F* drives *D* through *E* and *B* through *A*, thus giving the second speed. The relative position of the six gears is indicated by the diagram to the left of the figure.

The Didier Speed Gear for Cycles.—Another form of speed-changing device, constructed with permanently meshing spur-wheels, which may be thrown in and out of gear by the use of suitable clutches, is the Didier two-speed transmission for motor tricycles. As shown in an accompanying illustration, it consists of two sets of gear wheels, arranged on opposite sides of a suit-

able frame. A square portion of the crank shaft carries a pinion, *K*, having two claw-clutch surfaces, which may be slid in either direction by the lever bearing on its thimble. When the claw clutch is moved to the left, as shown in the figure, by operating the lever, *H*, the loose pulley, *C*, is thrown into gear with the

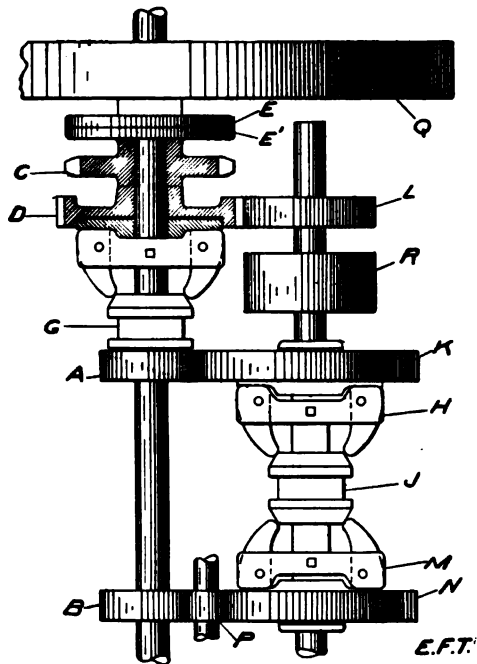

FIG. 363.—The Winton Change Speed and Reversing Gear. *A* and *B* are spur gears keyed to the crank shaft of the motor. *C* is a sprocket and *D* a gear, of one piece with it, which turn loose on the main shaft. *E* and *E'* are friction discs which connect *C* and *D* to the main shaft when the clutch, *G*, is thrown in. *K*, *L* and *N* are spur gears keyed to the counter-shaft, and meshing with *D*, *A* and *E* as shown. When clutch *G* is thrown in, the first speed forward is obtained; when clutch *H* is thrown in, the second speed forward; and when clutch *M* is thrown in, the reverse. The clutches, *H* and *M*, are operated by a lever actuating spool, *J*. *P* is an idler pinion reversing the motion transmitted from *B* to *N*. *Q* is the fly-wheel of the engine and *R* the sprocket drum.

rotating shaft, and turns the main drive-wheel, *B*, at the lowest speed. The second and higher speed forward may be obtained by shifting the clutch, *K*, to the right, so as to bring the loose spurs, *A* and *F*, into gear, thereby enabling the motion of the

motor to be transmitted through wheels, *F*, *E* and *D*, to pinion, *A*, which also drives the main drive-wheel, *B*, at a speed proportionate with the reduction obtained through the interaction of *F*, *E* and *D*. This is a simple example of speed-changing device, having several points in its favor, although it is hardly suitable for use on vehicles larger than tricycles. It gives a general idea of the mechanism employed for clutching loose gears on a rotating shaft.

The Winton Change Speed Gear.—The Winton change-speed gear, shown in an accompanying illustration, is a simple practical mechanism of the general type under discussion, which, by the use of three pairs of interlocking spurs and three friction clutches of familiar type, can give two forward speeds and a reverse. Briefly explained, the mechanism is operated as follows: The shaft of the engine carries two spur wheels, *A* and *B*, keyed in the position shown, and a sleeve carrying the sprocket, *C*, and the spur wheel, *D*. The main shaft and the sleeve are caused to rotate together through the contact surfaces of the friction clutch, *E*. To obtain the slow speed forward, the clutch, *F*, is thrown on by shifting the thimble, *G*, thus bringing the sleeve, carrying the sprocket, *C*, and the gear, *D*, into operative relations with the main shaft through the friction clutch, *E*. The second speed forward may be obtained by throwing in clutch, *H*, by sliding the thimble, *J*, and power is then transmitted from the gear, *A*, which is fast on the main shaft, through *K* and *L* on the countershaft to spur, *D*, which is screwed to the sleeve on the main shaft, in rigid relation with the sprocket, *C*. Similarly, the reverse movement is obtained by throwing on the clutch, *M*, by sliding the spindle, *J*, in the opposite direction, with the result that the motion is transmitted from the main shaft to gear, *B*, to gear, *N*, through the intermediate idler gear, *P*, to the countershaft, and thus, through *L* and *D*, to sprocket, *C*. While this gear is exceedingly simple and practical, it would be obviously difficult to obtain very many more speed variations without a suitable application of levers and shifting devices. However, since the motor of the Winton carriage is regularly controlled by an ingenious throttling device, to be explained later, it is not so essential to provide for a much more extensive range of mechanically shifted speed.

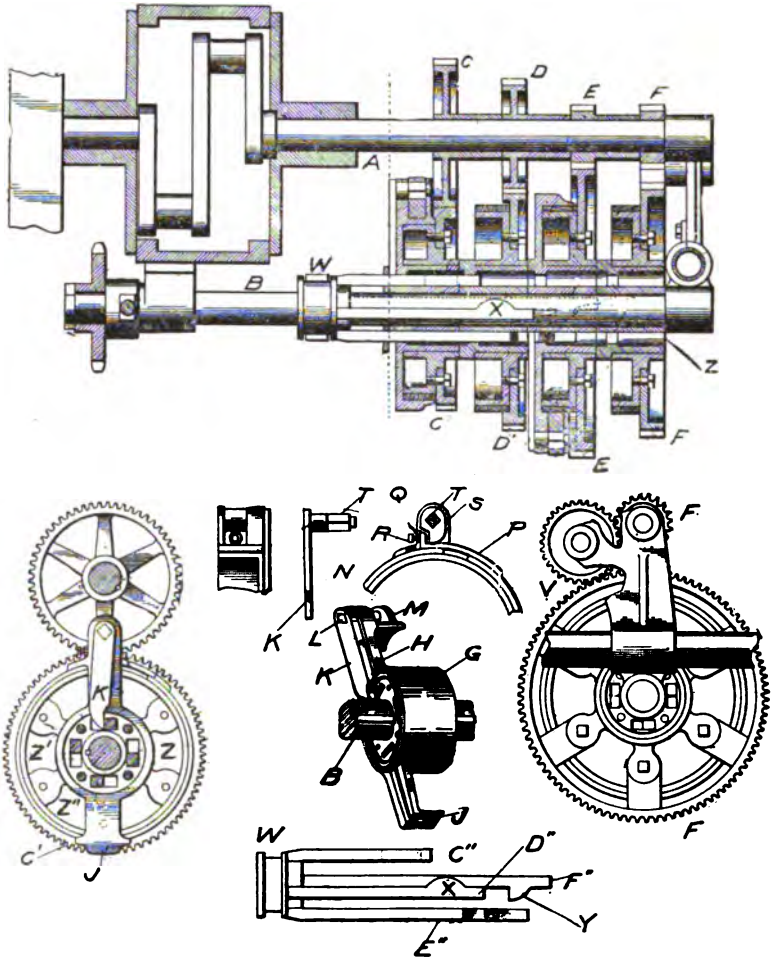

FIG. 334.—The Haynes-Apperson Change Speed and Reversing Gear. A is the first motion shaft; B, the secondary shaft; C, D, E and F, spur pinions keyed to A; C', D', E', F', pinions turning loose on B; G, drum keyed to B, on which the gears rotate loosely; H and J, arms cast integral with G; K, a lever arm pivoted at L on pin connected between bearings, M and N; P, forged nut of the strap around drum turning on G; Q, lug at end of P; R, an adjusting screw bearing against dog, S, carried on the same pivot as K; T, square portion of the pivot of K, to which is attached dog, S; V, an idler pinion giving reverse movement between A and B when gears F and F' are in gear. W is a spool for engaging a lever in sliding the sleeve, having the four fingers, C', D', E', F"; X and Y, lugs for clutching lever, K, on C', D', E' and F'; Z, channels in which the four fingers of the sleeve slide.

The Haynes-Apperson Change Gear.—A considerably more complicated clutch and loose gear speed-changing mechanism is found in the Haynes-Apperson transmission, the details of which are shown in accompanying illustrations. It consists of two parallel shafts, *A* and *B*, the former being driven direct from the crank as shown, and having four gears, *C*, *D*, *E* and *F*, keyed in its length. The countershaft, *B*, also carries four loose gears, *C'*, *D'*, *E'* and *F'*, each of which, as will be subsequently explained, is bolted to a drum, as shown in the illustration. Each of these brake drums, with its attached gear, turns loose on a separate drum, *G*, which is keyed to the countershaft, all of the attached gears, however, being able to turn through the motion imparted from their mates on the main shaft, without transmitting power to the driving mechanism. As may be readily understood, in order to transmit power through any one of the gears on the countershaft, it is necessary to make it rigid with its drum, *G*, which is keyed to the shaft, as already stated. For this purpose a somewhat complicated mechanism is employed.

As will be seen in the separate cut, each one of the drums, *G*, carries two arms, *H* and *J*, fixed diametrically opposite one another. On the arm, *H*, is carried a lever arm, *K*, pivoted at *L*, and having a short angle of movement by the attachment of its pivot to the bearings, shown at *M* and *N*. On the two extremities of the arms, *H* and *J*, are carried brackets, which hold the leather brake band against the circumference of the drum turning loose on *G*. One end of this brake band is riveted to the brake on *H*, the other to a forged strap, *P*, having at its extremity the lug, *Q*, through which works the adjusting screw, *R*, whose point bears against the dog, *S*. This dog, *S*, is carried on the square section, *T*, of the shaft attached to the lever arm, *K*, already mentioned; so that a slight movement of the lever, *K*, to the left, is imparted to the dog, *S*, whose point bears against screw, *R*, on the lug, *Q*; thus drawing the strap, *P*, tight around the drum, which is thereby made rigid with the sleeve, *G*, keyed to the shaft, *B*. By this means the gear attached to that particular drum imparts the motion transmitted to it from its mate on the shaft, *A*, to the countershaft, *B*, such motion varying in speed according to the ratios between the meshed gears. The act of giving the required axial movement to the lever arm, *K*, is performed as follows:

The sleeve, *W*, sliding on the countershaft, *B*, carries four fingers, *C''*, *D''*, *E''*, *F''*, of differing length, as shown in the figures. In the extremity of each of these fingers is a lug, such as is shown at *X* and *Y*, the object of which is to engage the point of the lever, *K*, on some one of the four arms, *H*, thus causing it to move its dog, *S*, and tighten the brake band, as already explained. In order to accomplish this act without interference, the positions of the levers, *K*, and of the dogs, *S*, differ in each brake drum. On drum, *C'*, for example, it is at the top of the shaft; in *E'* it is at the bottom; while in *D'* and *F'* it is on the right angle in either direction. For this reason, as may be understood from the cut, the four fingers carried on the sleeve, *W*, are similarly disposed, in order that their lugs, *X* or *Y*, may engage the point of the particular lever, *K*, which it is intended to actuate, without interference. In order that the fingers, *K*, may slide through the drum, *G*, keyed to the shaft, *B*, four suitable channels penetrate the entire series of drums, *G*, as shown at *Z* in the several cuts.

The sliding sleeve, *W*, is shifted by a lever working on the thimble on its outer extremity, and by causing its fingers to penetrate the channels, *Z*, more or less, can give three speeds forward and a reverse. The reverse is accomplished when the lug on the finger, *F''*, engages the lever, *K*, on the sleeve, *G*, belonging to drum and gear, *F'*, which act enables the motion of pinion, *F*, on shaft, *A*, to be transmitted through the idler, *V*, to *F'*, which will, of course, rotate in an opposite direction to *F*, thus reversing the motion of the shaft, *B*. The carriage is driven by a chain hung on the sprocket at the end of shaft, *B*.

The Duryea Transmission Gear.—The transmission gear used on the Duryea carriages, as shown in section and part plan in the accompanying illustrations, is a very efficient type of transmission operated entirely by friction clutches of large surface, which secures long life and easy operation, besides doing away with the wear and constant danger of breakage involved in the use of shifting gears. As indicated in these cuts, the small gear, *A*, is secured to the motor shaft against the fly-wheel flange by screw threads. Meshing into the gear, *A*, are three planet or idle gears marked *A'*, which are journaled upon studs provided on a triangular frame to receive them. This triangular

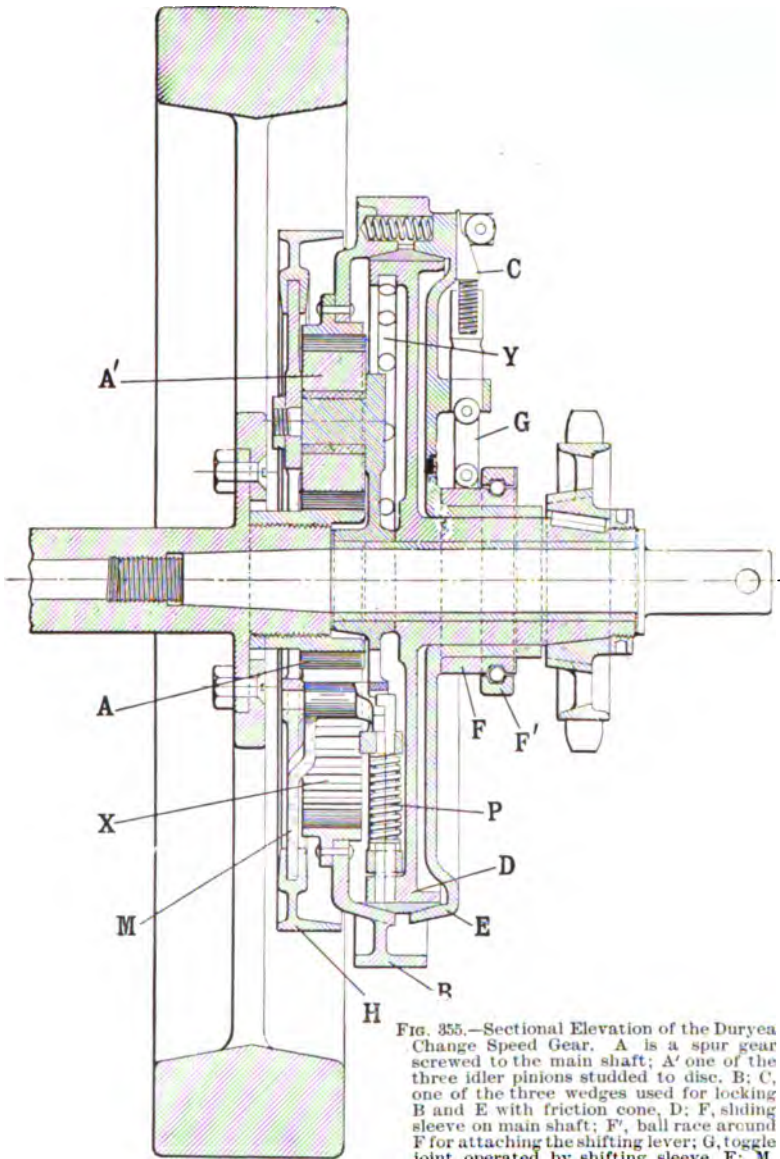

FIG. 355.—Sectional Elevation of the Duryea Change Speed Gear. A is a spur gear screwed to the main shaft; A' one of the three idler pinions studded to disc. B; C, one of the three wedges used for locking B and E with friction cone; D; F, sliding sleeve on main shaft; F', ball race around F for attaching the shifting lever; G, toggle joint operated by shifting lever, F; M,

lever for raising or lowering pin, P; X, an internal gear on disc; B; Y, a groove containing perforations for admitting pins, P, when H and B are locked together.

frame is journaled upon an extension of the motor shaft, by which arrangement the planet gears are held concentric with the driving gear, *A*, and both the gears and their supporting framework are further held in alignment with the various parts to which they may be attached in making the several changes. This triangular frame is double, one part being formed integral with the studs and the other part attached to the studs by nuts

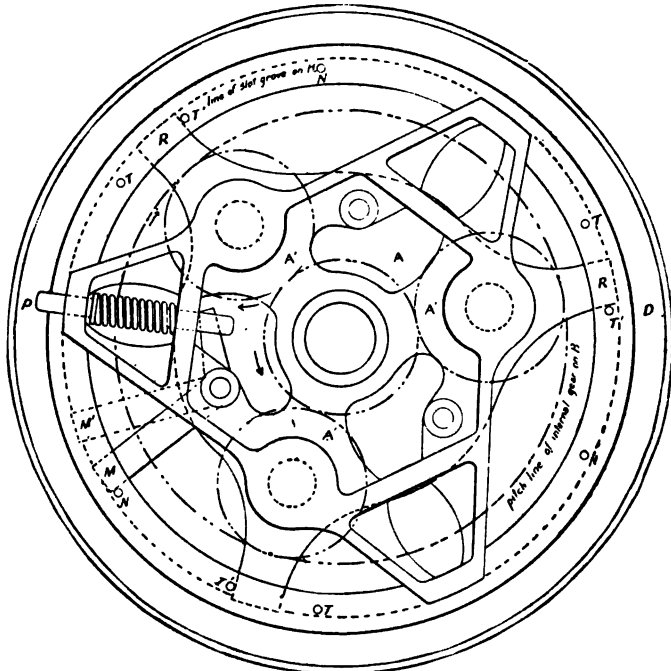

FIG. 356.—Front Elevation of the Duryea Change Speed Gear. The lettering here refers to the same parts as in the previous figure. *N* marks the position of the lever, *M*, when pins, *P*, are inserted in holes, *Y*, in *D*. *M'* marks the position of lever *M* when pins, *P*, are raised from holes in *D*. *R* and *R'*, arms of the spider, carrying the three idler pinions, *A'*, and sliding in a groove on *H* to the pins, *T* and *T'*.

on their projecting ends, which latter part carries the reverse ring, *H*, while both parts of the frame form supports for the clutch pins, *P*, and their actuating levers, *M*, of which the functions will be described later. Encircling the planet gears, *A'*, is an internal gear, *X*, attached to the slow-speed ring, *B*, which is supported upon the disc, *E*, by projecting lugs; while the disc,

E, in turn, is journaled so as to remain concentric with the motor shaft, and thus support the internal gear, *X*, in concentric relation and proper alignment with the other parts. Friction bands, not shown, are attached to the framework of the vehicle and encircle the ring, *H*, and the ring, *B*, being provided with levers by which either band may be caused to grip its corresponding ring at the will of the operator. If the reverse ring, *H*, is gripped by its band, the planet gear studs, with the attached framework, will be held stationary and the motion of the motor will be transmitted from the gear, *A*, through the planet gears, *A'*, to the external ring, driving same in a reverse direction, as shown by the arrows in the plan. If the slow-speed band is gripped upon its ring, *B*, the internal gear will be held in a fixed position and the motion of the motor will cause the planet gears, *A'*, to roll around inside the internal gear in the same direction as the gear, *A*, carrying the studs of the planet gears, *A'*, with their framework, slowly in a forward direction, as will be explained later. If all parts are locked together in any convenient manner so as to prevent relative motion, they will then move with the motor and cause the driving sprocket to move at high speed forward, while if no clutch is in engagement the motion of the motor will turn the gears idly without producing motion of the sprocket.

More specifically, these various motions are accomplished as follows:

The planet-gear frame is *normally* held in engagement with the sprocket carrying disc, *D*, by means of the pins, *P*, so that, holding the internal gear, *X*, by means of the slow-speed band—the other clutches being released—it carries the sprocket forward at slow speed. Since the planet-gear frame and the disc, *D*, are normally in engagement, it is evident that clutching the ring, *X*, to the disc, *D*, will prevent relative motion of the planet gears and the internal gear, and thus cause the sprocket to be carried at the speed of the motor. This effect is produced by means of conical friction surfaces on *D*, engaged by complementary surfaces inside the ring, *B*, and the disc, *E*, which surfaces are brought in contact by means of the wedge, *C*, bearing against the disc, *E*, under the roller attached to the lug projecting from the ring, *B*. This wedge, *C*, is operated by a shifting collar, *F*, and toggle link, *G*; a shifting lever, not shown, being attached to the outer ring of the ball bearing, *F'*. The section

shows these surfaces in engagement; releasing being effected by moving the shifting collar, *F*, toward the sprocket, which withdraws the wedge, *C*, and permits the friction surfaces to be separated by the spring shown. The large surfaces and the toggle and wedge arrangement for closing them, secure a very powerful pressure with little shifting effort, while the disc, *D*, is ordinarily surfaced with brass, which, having a higher expansion co-efficient than the cast iron against which it bears, is rapidly heated, in case of slipping, and becomes self-tightening by expansion. Releasing all the clutches allows the sprocket with its disc, *D*, and the planet-gear frame to stand idle while the internal gear revolves freely in a reverse direction, as shown by the arrows, although the motor may be running.

The reversing effect is secured by holding the ring, *H*, which is mounted on the arms of the planet-gear frame, in such a manner that the frame may move a short distance before it is stopped by pins, *T'*, which motion moves the lever, *M*, into the dotted position, *M'*, and withdraws the pin, *P*, from engagement with the disc, *D*, thus separating the planet-gear frame from the sprocket disc, *D*. Since the pins, *T'*, prevent further movement of the planet-gear frame, while the disc, *D*, is free to move in any direction, it is evident that the motion of the motor will drive the internal gear, *X*, in the reverse direction, and that clutching the gear, *X*, to the sprocket disc, *D*, by means of the high-speed clutch, will cause the sprocket to be carried in the reverse direction along with the gear, *X*. It is further evident that releasing the high-speed clutch will stop the reverse movement of the sprocket, while releasing the reverse ring, *H*, will permit the pins, *P*, to resume their normal position, under the action of their springs.

The whole device is quite compact, and therefore readily placed by the side of the motor, on a short extension of the motor shaft, which being removable permits the entire power gear to be quickly assembled, or removed for inspection or repairs. Further, the power is transmitted from the driving gear, *A*, to the various clutch surfaces, in approximately a single plane, which lessens the torsion strains on the various parts and gives great strength with little weight of material. All parts are concentric or balanced, and, therefore, adapted for use at high speeds, while removable bushings secure long life.

The driving sprocket is the outermost portion of the gear and may be removed, for the substitution of a larger or smaller one, by loosening a single lock nut after the shaft bearing is removed.

The De Dion & Bouton Speed Gear.—The two-speed transmission of the De Dion & Bouton carriages is shown in two sections by accompanying illustrations. Briefly described,

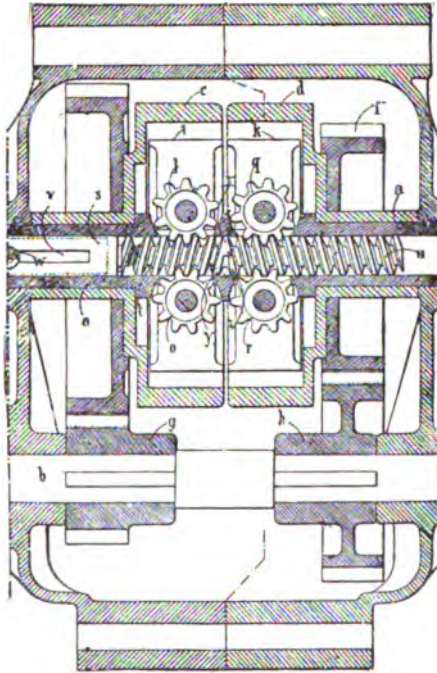

FIG. 357.—Longitudinal Section through the De Dion & Bouton Two-speed Change Gear.

it consists of a hollow driving shaft, *A*, on which are two loose gears and their clutch drums, *C* and *D*, and a secondary shaft, to which are keyed two spur pinions, *G* and *H*. Within the hollow driving shaft, *A*, slides a round shaft, *S*, upon the extremity of which is carried a right and left handed screw, *U*, as shown. This rod, *S*, is arranged to slide in the hollow shaft, *A*, its motion being controlled by a rack and pinion movement

operated by a sprocket, as shown in the external view of this mechanism. The object of sliding the rod, *S*, within the hollow shaft is that the right and left handed screw, *U*, may operate as a rack to impart a certain axial movement to the pinions, *O*, *P*, *Q* and *R*. As shown in the transverse section of this mechanism, these pinions are mounted on right and left threaded axles, screwing into adjustable bearings or sleeves. Consequently, as

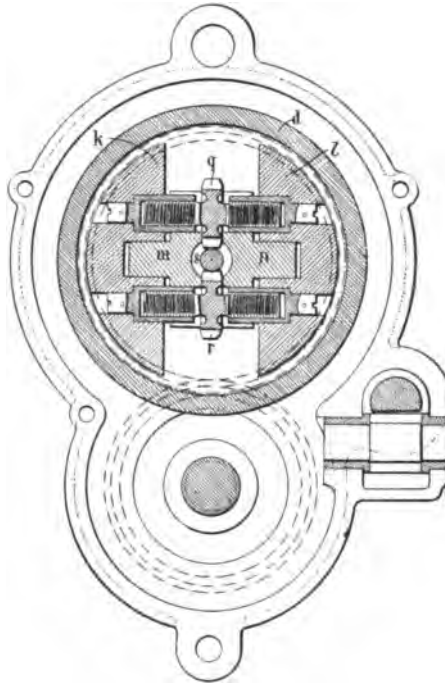

FIG. 358.—Cross Section through the De Dion & Bouton Two-speed Change Speed Gear.

may be understood, the longitudinal movement of the screw rack, turning the pinions on their screw axles, tends to force them in or out of the sleeves in which they work. The result is that the segments, *K* and *L*, shown in transverse section, are forced firmly against the internal circumference of the drum, *D*, thus clutching it and producing a rigid driving connection between the hollow rotating shaft, *A*, which, in its rotation, car-

ries around the entire system, including the internal rod, *S*, double screw, *U*, and the pinions, *O*, *P*, *Q* and *R*. This rotative movement is insured by the slides, *M*, *N*, with which the segments, *K* and *L*, are always in fixed relations. The operation of disengaging the one clutch is always contemporaneous with the engaging of the other, through the pinions, *O*, *P*, and the left-hand operation of the double screw. As may be understood, the speed of the carriage varies, according to the gear that is in mesh with the pinions on the countershaft, since, being of

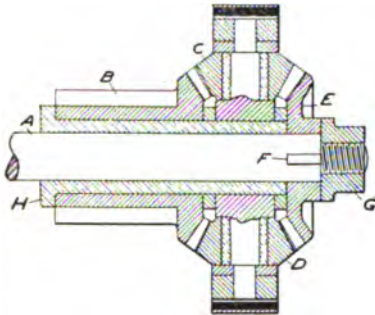

FIG. 359.

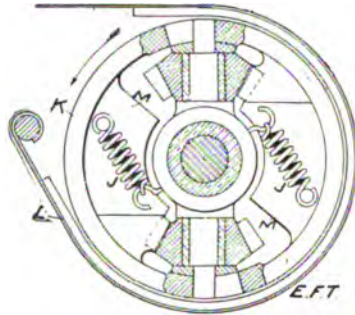

FIG. 360.

FIGS. 359, 360.—De Dion & Bouton Reversing Gear. *A* is the counter-shaft passing through the change speed gear; *B*, a spur pinion for driving direct to the differential gear, and having a bevel gear at one end engaging the bevel pinions, *C* and *D*; *E*, a bevel gear keyed to *A* at *F*; *G*, a nut holding *E* in place. *H* is a sleeve on *A*, on which gear, *B*, turns loosely. *J* and *J* are springs attached to the brake drum, *K*, and holding the bevel pinions, *C* and *D*, against the stop pieces, *M* and *M*. The reverse motion is obtained when the band, *L*, is tightened, preventing the rotation of *K* and drawing bevel pinions, *C* and *D*, from engagement with stop pieces, *M* and *M*, thus allowing them to rotate on their own axes and reversing the motion imparted by drive pinion *B* to its bevel gear end. The bevel pinions, *C* and *D*, are studded to a two-armed spider which, as shown, turns on shaft, *A*.

different diameters, the speed and power ratios are varied accordingly. In former models of this speed-changing gear a plain double-rack arrangement was employed, instead of the double-threaded rod, as shown in the present illustration. The advantages claimed for the improved device are that any wear may be readily adjusted without removing the rod from the hollow shaft, *A*, thus disarranging the entire mechanism; all that is necessary being to loosen the screw, *W*, fixed in the slot, *V*, and rotating the rod, *S*, to the required position.



FIG. 361.—A Forty Horse-Power Panhard-Levassor Racing Car, with tonneau carrying two additional passengers. The Panhard carriage represents the highest development of motor vehicle construction along the lines laid down by Daimler. They furnish the models on which the most approved styles of gasoline carriages are built.

CHAPTER THIRTY-TWO.

THE DEVELOPMENT OF THE GASOLINE MOTOR VEHICLE BY GOTTLIEB DAIMLER AND HIS SUCCESSORS.

Daimler's Contributions to Explosive Motor Construction.—

The use of explosive motors for propelling road vehicles was made possible by the inventions of Daimler, after whose designs practically all vehicle motors are constructed to the present day. The improvements introduced by him were principally those that made it possible to use a mineral spirit or liquid fuel, and the attainment of a higher speed than was possible with the older engines of the Otto type. With increased speed, a lighter weight and smaller proportions were made possible. The Otto engines in use until the date of his memorable inventions could attain only a very slow speed, both on account of the complicated and uncertain slide valve arrangements and also from the system of igniting the charge by the constantly burning gas jet and slide. Daimler struck at the root of the difficulties and constructed his earliest types of engine with the poppet valves, now in universal use, and with the familiar hot-tube ignition. This latter contrivance alone was largely instrumental in attaining the end of high speed, since, as already described, ignition is directly due to forcing of fuel mixture into the incandescent tube by the pressure of compression. This method of contact was, of course, impossible with the flame and slide ignition, as was also any very high degree of compression. Consequently, only the lowest speeds were attainable with the older Otto engines. Daimler, furthermore, constructed his cylinders with a stroke long in proportion to the total content, thus permitting such high compressions that the heat of the cylinder walls was sufficient to produce ignition of the charge, after the first few strokes ignited by the hot tube, or "priming-cap," as he called it.

Daimler Valve Governors.—The inlet valves of the early forms of Daimler engine were operated by atmospheric pressure acting against a vacuum created by the out-stroke of the piston, as in all gasoline cylinders of the present day. His ex-

haust valves were positively operated with the familiar cam-actuated push-rod, although the cam mechanism, instead of working on a secondary shaft, as at present, consisted of two eccentric grooves on the face of one of the inclosed fly-wheels, in which traveled a feather at the end of the valve rod.

By means of a switch operated by a simple governor, the

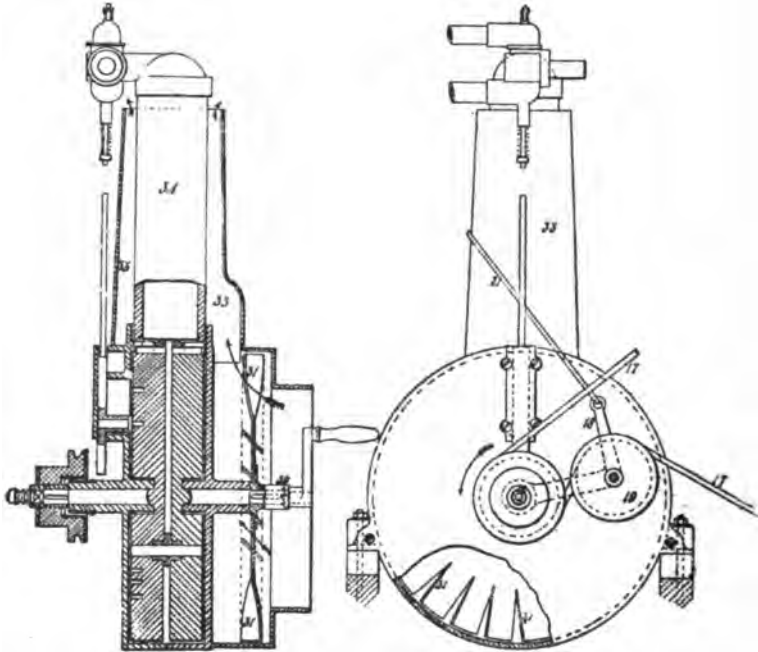

FIG. 302.—Diagram of the earliest Daimler Gasoline Motor; used on Daimler's first bicycle. The parts are indicated by numbers as follows: 17 is the driving belt passing around the pulley on the main shaft and tightened by jockey pulley, 19, and link, 21. 31 is a rotary fan, consisting of a number of radial fins as shown, which keeps a current of air passing through the air jacket, 33. 34 is the cylinder shown in part section.

feather running in the cam groove could be shunted from its regular course, so as to run in a nearly circular path, thus giving no motion to the exhaust valve, and keeping it closed. So soon, however, as the speed began to fall to the normal, the governor again shifted the switch, with the result of again resuming the operation of the valve, and exhausting the burned-out gases con-

tained within the cylinder. The shunting governor was speedily replaced by another form of valve-controlling device, in which a centrifugal ball governor on the main shaft was arranged to move a sliding sleeve outward and actuate an upright lever. The upper

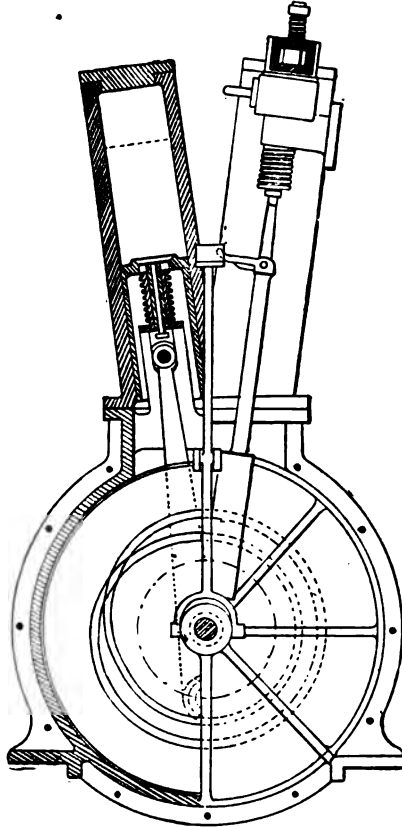

FIG. 363.—Part sectional view of the Daimler V-shaped Gasoline Engine, showing the air valve in the piston and eccentric cam grooves on the fly-wheel disc. The method of opening the exhaust valve is also indicated.

arm of this lever, moving inward toward the cylinder, deflected the push-rod working in the cam grooves, so as to make it miss the end of the valve rod, thus causing the valve to remain closed until the speed again falls to normal. A governing device of this description is shown in an accompanying figure.

The Piston Air Valve of the Daimler Engine.—Another feature of the earlier Daimler engines was the supplementary air valve in the piston, the location and general construction of



FIG. 304.—The Daimler V-shaped Gasoline Engine, with carburetter and parts attached. The object of constructing an engine with cylinders arranged as shown is to double the power capacity without correspondingly increasing the weight. This style of motor has been practically abandoned, and is no longer manufactured by the Daimler Companies.

which is shown in the half-sectional view of the V-shaped engine. The object was to compensate the imperfect operation of the surface carburetters used with these engines, and secure the in-

jection of a sufficient additional quantity of air to secure the combustion of the charge. The operation of this valve involved that the crank chamber should serve as a reservoir for air admitted through a valve in its wall under suction of the piston during its in-stroke. On the out-stroke of the piston which draws in the fuel mixture through the inlet valves, the piston air valve is caused to open, by the superior pressure of the air in the crank chamber and in front of the piston. As shown in the half-sec-

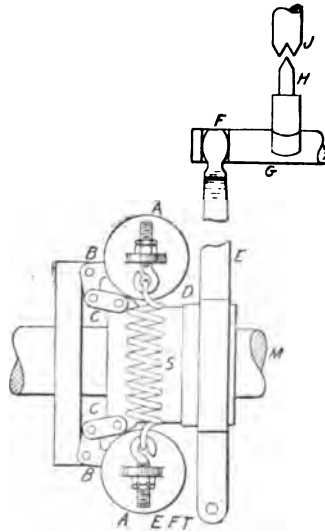

FIG. 365.—One type of Gas Engine Governor, which is an improved variation of the device used on the early Daimler motors. The parts are as follows: A and A, ball weights; B and B', bell cranks actuating the links, C and C', as the balls move outward resisting the tension of spring, S, and sliding sleeve, D, on the shaft, M. E is a lever arm attached to D, which moves the shaft, G, by contact at F, as shown, thus throwing the pick blade, H, out of contact with the end, J, of the exhaust valve rod.

tional drawing of the V-shaped engine, the valve spring bears at one end against the inside end wall of the trunk piston and at the other against a shoulder sliding on the valve stem. On the out-stroke, accordingly, this shoulder comes into contact with the fork shown on an upward inside projection from the lower end of the cylinder, being forced upward and compressing the spring against the upper wall of the piston. The valve rod, being thus relieved from spring pressure, is free to rise in obedi-

ence to the superior pressure of the air within the crank case, which is forced in as the fuel charge enters from the opposite end. During the firing stroke the spring is similarly compressed, although, owing to the greater pressure of the expanding gases behind the piston, the valve is held in its seat. This piston valve

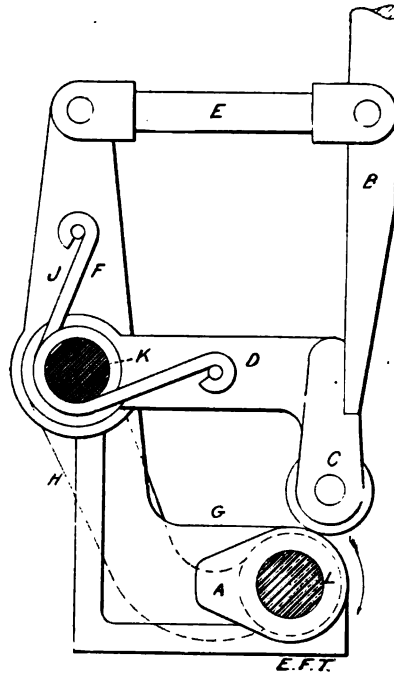

FIG. 396.—Governor Mechanism of the later Daimler Motors. As shown in this cut, the cam, A, bearing upon the roller, C, lifts the arm, D, pivoted at K, and held in position by a spring, J. By lifting arm, D, it also lifts pushrod, B, which opens the exhaust valve. When, however, the speed of the motor has increased beyond the predetermined limit a sleeve of varying diameter, sliding on the same shaft, L, to which the cam, A, is fixed, is moved so that the larger diameter is brought to bear against the downward extension, H, of the arm, F, thus causing F to incline on the pivot, K, toward the cylinder (at the right as in the cut), hence pushing rod, B, by link, E, out of range of arm, D, as it is moved upward by impulse from cam, A. In this case the exhaust valve is not opened and the products of combustion being retained in the cylinder, there is no feeding of fresh fuel gas.

was used on Daimler engines for only a few years, its function being afterward discharged much more satisfactorily by adjustable air inlet valves in connection with the carburetting and mixing chambers.

The V-Shaped Two-Cylinder Engine.—The Daimler motors are now manufactured on two well-known models: single upright cylinder and double upright parallel cylinder engines. The V-shaped engine was at one time the typical Daimler engine. The object sought in its design was to secure an upright construction, with the full effect of two cylinders operating on the same crank, thus saving both space and weight, in a manner impossible with opposed cylinders of long stroke.

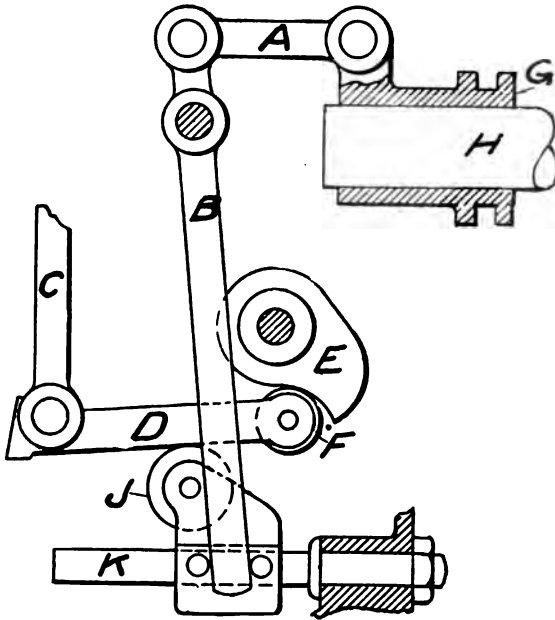

FIG. 367.—Mechanism of the Peugeot Variable Exhaust Valve Lift. A is a link attached to spool, J, sliding on the rotating shaft, H, as shaft G is slid backward or forward according to the impulses of the centrifugal governor. The link, A, actuates the lever, B, sliding the roller, J, on shaft, K. The roller, J, forming the fulcrum of lever, D, being thus slid backward or forward, varies the lift of valve rod, C, as actuated by the cam, E, bearing upon the roller, F.

Water Cooling and Ignition Devices.—In the early engines of the Daimler pattern the cylinder cooling was accomplished by means of a rotary fan worked on the crank shaft of the engine, and forcing the air through a form of jacket surrounding the entire upper portion of the cylinder. The floats of this fan are

shown at the points marked 31 in an accompanying illustration, and the jacket at 33. By this device a constant current of cold air was forced against and around the cylinder. Of course, the later Daimler motors, designed for vehicle use, have the ordinary water-jacket cooling system, any form of air-cooling being evidently inadequate to the demands of even average traffic.

The hot-tube ignition is still used by the Daimler companies of Germany, England and America, as also by several of the French motor-carriage builders using the Daimler engines. This system is successful on account of the long stroke, characteristic of the Daimler cylinder, which gives a correspondingly high

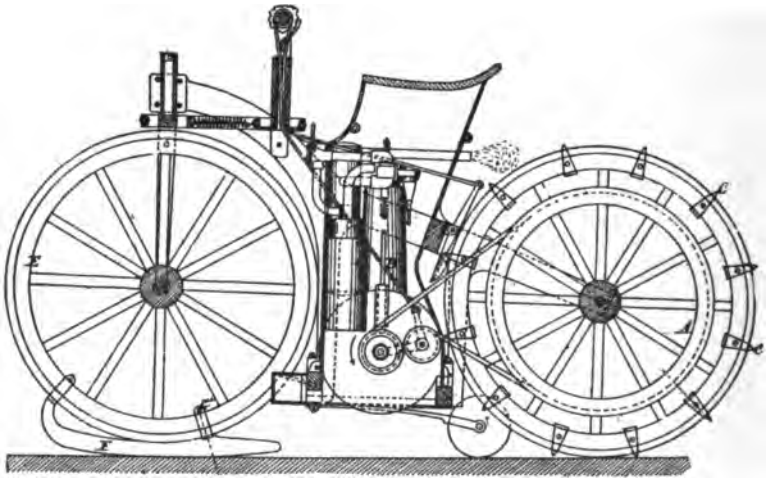

FIG. 388.—Sketch of Daimler's First Gasoline Propelled Bicycle. This machine is shown arranged for sliding on ice, having teeth, C, in the rear wheel, and the runner, F, secured to the forward wheel, E. A is the driving pulley on the rear wheel; B, the cylinder of the motor.

compression ratio, involving certain and efficient ignition of the charge at high speeds. However, certain European automobiles, such as the Mercedes-Daimler, have latterly been constructed with the primary circuit break-contact system, with current supplied by magneto-generators. Some of the later Panhards are equipped with the jump-spark ignition.

Daimler's Early Motor Carriages.—The first application of the Daimler motor to the work of propelling road vehicles was

made in 1885, when Daimler built the motor bicycle, or velocipede, shown in an accompanying illustration. The motor was hung between the wheels from a heavy iron framework, and directly above it was the seat. Just below the motor, and connected to the platform on which it rested, were two auxiliary rollers or small wheels, which could be drawn up or lowered by the pressure of the driver's feet on a pedal. The object of these rollers was to afford a support for the vehicle when the motor was not in operation.

On the earliest bicycle of this type, which saw its first success-



FIG. 369.—The First Daimler Motor Carriage. The motor was connected to the driving axle by two belts; one for high speed, the other for climbing; either being thrown into action as the belts were tightened by jockey pulleys, as shown in Fig. 347. Both could be thrown out of action to stop the carriage without stopping the motor. The forward axle of this carriage was centre-pivoted and turned on a fifth wheel, as in horse carriages; the steering being by upright pillar rising before the driver's seat.

ful trial on November 10, 1885, the driving was by a belt from a pulley carried on the crank-shaft to another one of larger diameter, attached to the rear wheel. The motor was started by a crank in the usual manner, and the power was thrown upon the vehicle wheels by drawing up the jockey pulley, thus tightening the belt. While there were no provisions on this bicycle for varying the speed during travel, it was possible to shift the belt between two pulleys of different diameter attached to the driving-wheel, thus securing some slight variation.

The motor used in connection with this bicycle was a Daimler

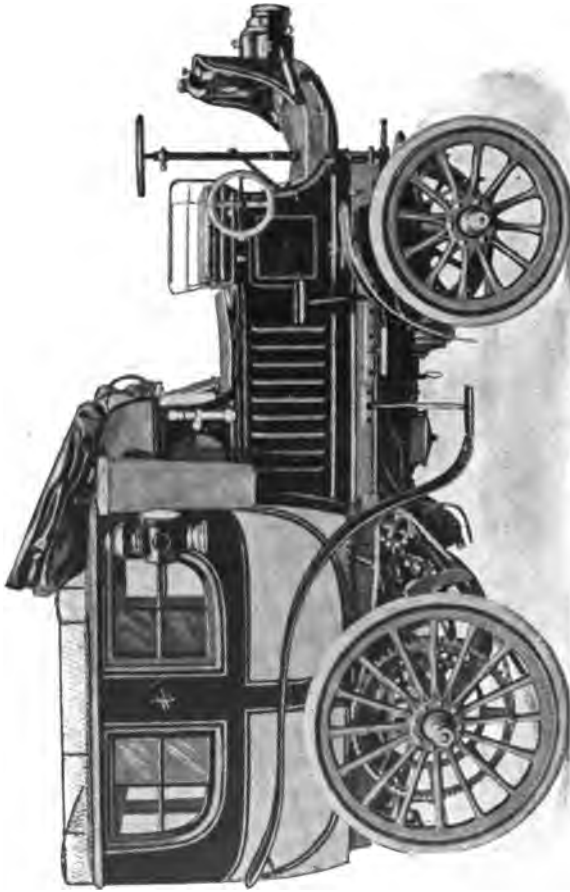

FIG. 370.—12 H. P. Coach, built by Panhard-Levassor. This coach has a capacity for carrying twelve passengers, including the driver, and represents a type that has given good service, both in town and country use.

upright single-cylinder engine, such as has already been described. The connections and manner of shifting the jockey pulley or idler, used for tightening the belt, are shown in the detailed cut of the motor. The belt transmission used on the early bicycles is practically the device used on Daimler's motor carriages for a number of years. As a matter of fact, numerous writers speak of this form of transmission as a typical feature.

The earliest four-wheeled vehicle propelled by a Daimler motor was built in 1886. It seems to have been a modified horse carriage, having the forward axle turned by an upright steering

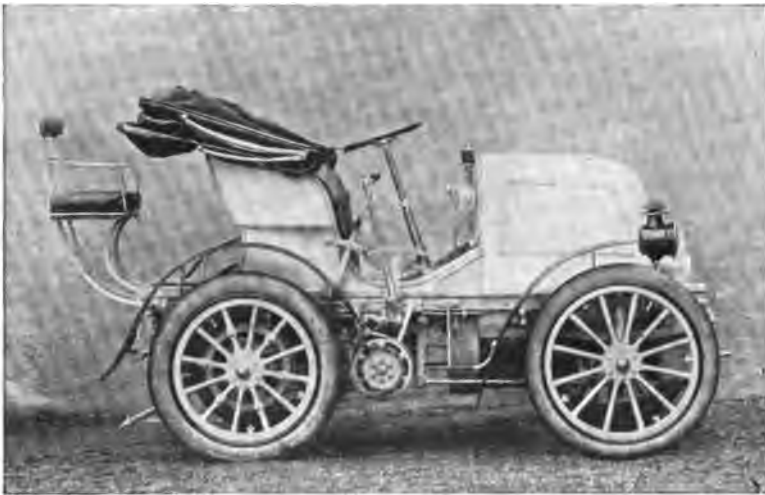

FIG. 871.—Two-seated Pleasure Carriage for general use; built by the Cannstadt-Daimler Co.

pillar and hand-wheel, and with driving pulleys secured to each of the rear wheels. As shown in an illustration, which was reproduced from a German book, a motor of the same general type as that used on the bicycles was placed behind the forward seat, and imparted its power direct from the main shaft to the driving pulleys on the rear wheels. In the later Daimler carriages four speeds were obtained by four pulleys of different sizes on the main shaft, and four others on a countershaft, the system of tightening the belts by idlers being still followed, as explained in the chapter on speed gears.

The Work of Panhard-Levassor and Others.—One of the most important chapters in the history of gasoline motor-vehicle development is to be found in the work of the French firm of Panhard & Levassor, whose name is still regarded as among the foremost in the automobile world. This firm were originally manufacturers of various kinds of industrial machinery, and brought to the manufacture of motor vehicles a long experience and a well-equipped plant. Evidently foreseeing the possibilities of the Daimler engine and carriage, they, in 1890, secured the French rights to manufacture both. Thereafter, for several years, other French manufacturers of motor vehicles using the



FIG. 372.—Heavy Victoria Touring Carriage; built by the Cannstadt-Daimler Co. This type of carriage has been widely used in various parts of Europe for touring, and has a high reputation for hill climbing.

Daimler motors were obliged to obtain their engines from Panhard-Levassor.

Not only are the Panhard vehicles notable from the fact that they were among the earliest successful carriages, but also because, owing to the vast skill and experience of their manufacturers, they embodied principles of design which are recognized as the most excellent for motor carriage purposes, and some of which must certainly continue permanent. Among these excellent elements of construction may be mentioned the fact that from the very first they adopted a wooden underframe, at

first sheathed with angle-iron, later consisting of wooden bars, and at no time in the development of their vehicles did they waste time and ingenuity on the steel tubular framework, which many manufacturers still seem to consider essential for securing the combined ends of strength and lightness. Among the earliest

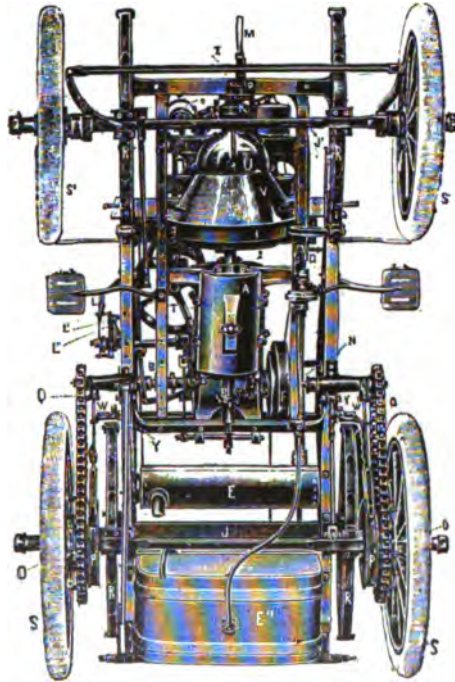

FIG. 373.—Plan of the body and underframe of the average weight Panhard-Levassor Carriage, showing machinery and general apparatus in position. A is the case containing the change speed gear; B, the reversing connections; C, the carburetter; D, the circulation pump; E, the muffler; E', the water reservoir; F, the differential gear case; L, the braking lever; L', the reversing lever; L'', speed changing lever; O, the sprocket on the rear wheels; Q, the driving chain; S, the rear wheels; S', the forward wheels; T, the steering gear; U, the motor case; V, the case enclosing the flywheel and main clutch; W, the attachment for controlling the brakes; X, the adjustable distance rod between the carriage body and the rear wheels; P and P, drums for the band brake; (1), female cone of the main clutch; (2), male cone of the main clutch.

known examples of steel tubular construction was the Peugeot-Daimler carriage of 1895.

The general designs of Panhard-Levassor were adopted by the English Daimler Motor Co., and also had a great effect on the



FIG. 874.—A Heavy Delivery Wagon, manufactured by the American Daimler Co.

subsequent construction of the German manufacturers. The earliest types of their carriages, as also manufactured by Peugeot Brothers and the English Daimler Motor Co., were equipped with the famous V-shaped Daimler engine, which was, however, of not more than 6 H. P. Very early in the development of their

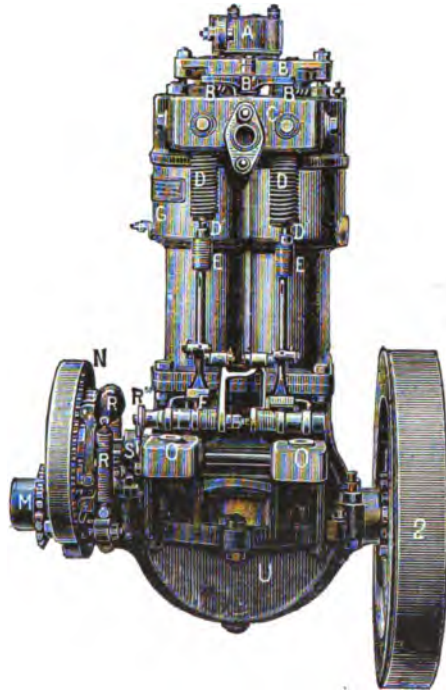

FIG. 375.—The Phenix-Daimler Double-vertical Cylinder Carriage Motor, as used by Panhard-Levassor. A is the port for admitting fuel gas under piston suction; B, the inlet valve; B', the exhaust valve; C, the ignition apparatus; D, spring on the exhaust valve; D', exhaust valve rod; E, pushrod actuated by the cam; F, governor attachment; N, wheel on the cam shaft, carrying the governor; R, the centrifugal weights of the governor; R', the governor springs; R'', sliding cam shaft; S, the cam actuating the exhaust valves; U, the engine flywheel carrying the female cone of the main clutch.

carriages, also, this firm devised and constructed the speed-changing gear, which has already been described under their name. A very similar structure was used on the Peugeot carriages, the principal difference lying in the fact that the reverse motion was accomplished by throwing into gear an extra spur-

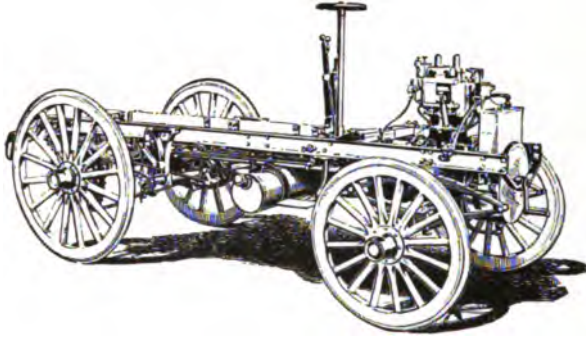

FIG. 376.—Running Gear of the Heavy Delivery Wagons manufactured by the American Daimler Co., showing the motor and machinery in position.

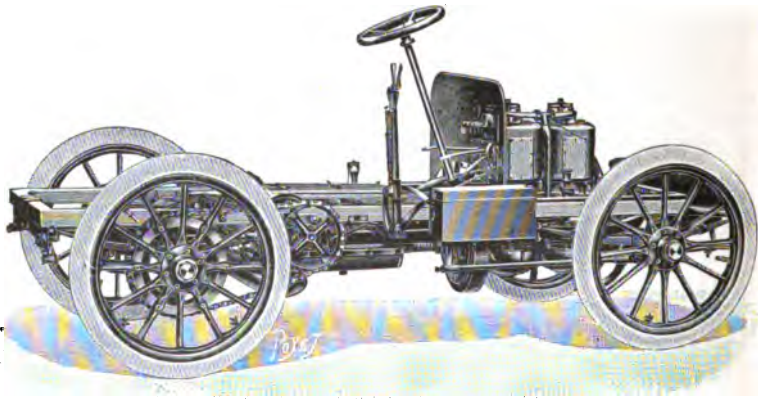

FIG. 377.—Running Gear of the Charron carriage; one of the newer makes of French automobiles, constructed on the general models of the Panhard-Levassor. The completed carriage is shown on page 330.

wheel or idler, which was of sufficient length along its spindle to connect together two spurs on the interacting shafts, apart from the ordinary process of shifting. The latter description of gear is the same in general principles as was used on some of the later cars constructed by the Cannstadt-Daimler Co.

Another structural feature of the Panhard carriages was, following along the now accepted Daimler lines, placing the motor over the forward wheels and covering it by a sloping fore-structure

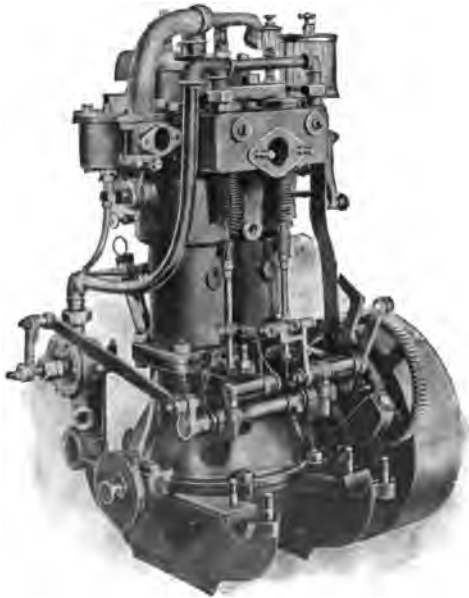

FIG. 378.—Double-vertical Cylinder Motor, used on the wagons manufactured by the American Daimler Co.

ture or bonnet. With the Peugeuts, Benz, Mors, De Dion, and several other well-known designers and builders, the usual plan was from the start to hang the motor over the rear axle, and some of the earlier carriage constructions resulted in so overloading the rear wheels, that, according to some authorities, steering was rendered difficult. As the science of vehicle construction increased, however, this difficulty was fully overcome,

and it is now a well-accepted principle of construction that, while the forward axle should bear its own part of the load, the bulk of the weight should rest over the rear axle.

Another departure soon made was the abandonment of the V-shaped Daimler motor and the substitution of the parallel double-cylinder type, now in common use. One notable feature in the development of this type of engine is worthy of mention. In the earlier models used by Panhard-Levassor and by the English Daimler Motor Co. the cranks were set at 180 degrees, so that while one cylinder was performing its out-stroke, the other was at the in-stroke. This arrangement was adopted for the purpose of securing a balanced movement by the neutralization

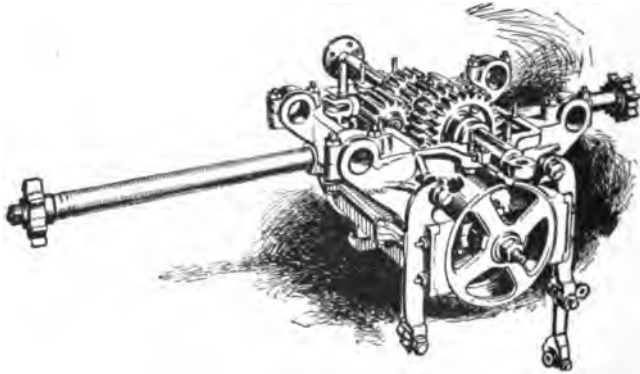

FIG. 379.—Change Speed Gear, used on the heavy gasoline delivery wagons manufactured by the American Daimler Co.

of vibration. With the later Panhard vehicles, however, both connecting rods were made to work on the one crank, with the result that both pistons performed their out-stroke and in-stroke simultaneously. The balance of movement and the end of securing an explosion for every revolution of the crank-shaft were, however, attained by making the explosion stroke in one cylinder contemporaneous with the suction stroke in the other, and the succeeding strokes of the cycles in both in the same order.

CHAPTER THIRTY-THREE.

THE DE DION CARRIAGE AND MOTOR.

The De Dion & Bouton Engine and Carriage.—Among the machines of French manufacture that have attained to almost as wide a reputation as the Panhards and others following the Daimler model, we may mention the carriages manufactured by the firm of De Dion & Bouton, of Puteaux. The accompanying illustrations of the De Dion motors and carriages give an idea of the constructions familiar in this country. The motors, although built on the same general plan as the typical Daimler vehicle engines, with the enclosed crank and fly-wheel cases, differ from them in a number of other particulars. As may be seen in the accompanying cuts, the cylinder has a shorter stroke in proportion to its total content than has that of the typical Daimler. The water jacket, also, extends through the greater portion of the stroke instead of covering only the cylinder head and the area included in the combustion chamber. The exhaust valve is opened by a push rod actuated by a cam on a secondary shaft, but no provision is made for governing the speed, as is the rule with the Daimler engine. That function is accomplished solely by throttling the charge by means of a lever at the driver's hand, as in a number of other carriages, American and foreign. The De Dion motor was one of the earliest, after Benz, to use the method of igniting by jump-spark, the details of the circuit arrangements having been already explained.

As shown in Fig. 64, the running gear or underframe of the De Dion carriages is of steel tubular construction. The body also rests upon another tubular framework, which is hung upon the springs carried on the two axle shafts, although, like the majority of French machines, the general mechanism is, from the American point of view, somewhat complicated. The numerous excellent features included entitle this carriage to consideration among the best of its class. The compensating device for securing a steady operation of the steering mechanism in spite of the vibration of the springs, has already been described in connection with Fig. 79. Also the system of universal joints

on the rear axle, enabling the differential gear drum to be hung from the body frame, thus permitting an uninterrupted spur drive, as shown in Fig. 80.

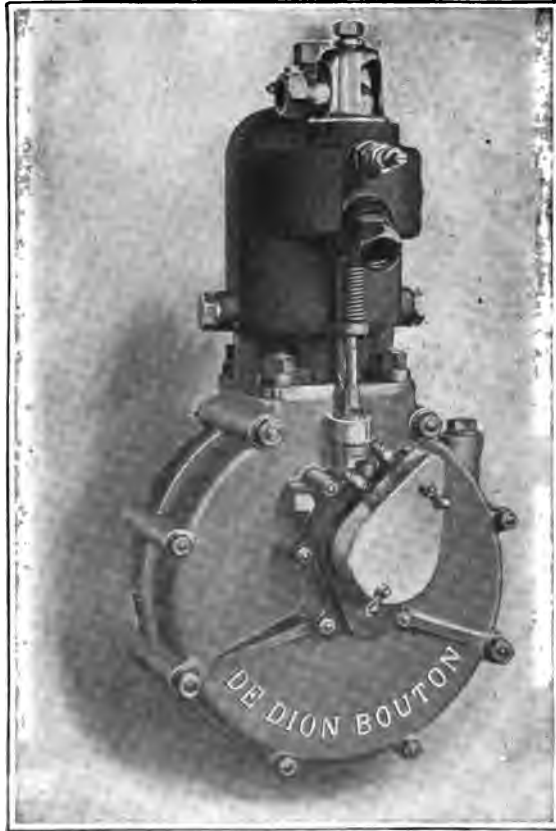

FIG. 80.—De Dion & Bouton Water Jacketed Carriage Motor, of the style used on light road carriages, and rating between $8\frac{1}{4}$ to 5 H. P.

Power Transmission and Braking.—The main shaft of the engine is connected direct through the coupling sleeve with one shaft of the change-speed gear, as already described in a previous chapter, and the secondary shaft of this same gear carries a spur pinion, which drives on the spur attached to the compen-

sating gear drum. The speed-changing gear is operated by a special lever on the common steering and operating pillar before the driver's seat, and the reverse is attained by manipulating the spur lever, which throws on a small positive clutch, thus reversing the motion of the countershaft, as already described. There are three brakes, one having its drum directly to one side of the differential gear, which is operated by a pedal directly in front of the driver's seat; the two others for use in emergencies, the drums of which are attached to the hubs of the driving wheels, and may be manipulated by pressing down on the reversing lever, already mentioned. The motor may also be used as an effective auxiliary brake, especially when coasting down hill, by simply cutting out the electric circuit and leaving the clutch



FIG. 381.—One model of the De Dion & Bouton Voiturette, seating two persons, with an additional forward seat on the boot in front. This carriage is fairly representative of most of the models of this make.

connected—allowing the cycular operations to be directly reversed. In this case the wheels drive the motor as an air compression pump.

The various operations involved in operating and controlling a De Dion carriage are explained in the diagrams.

Explanation of the Diagrams—The Steering and Control.

—Fig. 383 is a diagram plan of the De Dion carriage, illustrating the steering and gas circulation systems and the connections of the control levers for regulating the gas supply and spark. The steering connections are indicated by the lines in the diagram as follows: At *A* is shown the steering handle on the combined steering and control pillar, which by spur pinions and rack connections operates the link, *B*, which turns the bell crank compensating gear, *C*, the details of which are shown in Fig. 79. As

may be understood, from reference to the last named figure, the link bar, by means of its pivoted connection to a knob at the base of the V-shaped pieces on the compensating device, moves the links, *D* and *E*, giving the required angularity to the steer-

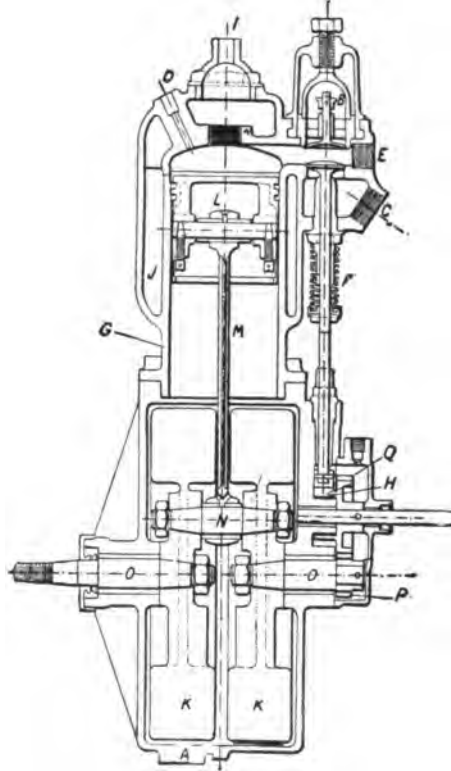

FIG. 382.—Section of the De Dion & Bouton Water-jacketed Carriage Motor, showing parts and construction of the engine shown in Fig. 380. The parts are as follows: *A*, the crank case formed by two cylindrical pieces bolted together; *B* is the inlet valve for the fuel mixture from the carburetter; *C* is the exhaust valve, formed of solid nickel steel, held closed by a helical spring, *F*, and opened at definite intervals by the cam, *H*; *D* is the opening for screwing on the compression tap; *E* is the threaded hole for screwing in the sparking plug; *F* is the spring on the exhaust valve rod, which normally holds the valve closed; *G* is the cast iron cylinder which is bolted to the crank case; *H* is the exhaust cam cast in one piece with the gear, *Q*, which is actuated by the pinion, *P*, on the crank shaft; *I* is the port of exit for the jacket water circulating through the jacket, *J*, the inlet being at a point near the base of the jacket; *K* and *K* are the fly-wheels, or crank-discs, which are joined together as shown, by the crank pin, *N*; *L* is the piston whose construction corresponds to that shown in Fig. 284; *M* is the connecting rod of drop-forged steel; *N* is the crank or wrist pin connected to the fly-wheel as shown, and serving as a bearing to the lower end of the crank rod; *O* and *O* are the crank shafts, that on the right carrying the pinion, *P*, that on the left being threaded for connection to the driving gear; *P* is a pinion on the crank shaft meshing with gear, *Q*, on the cam shaft.

ing arms, *E E*, on the pivoted stud axles, *F F*. As previously explained, the compensating device enables a positive steering action, although the up-and-down movement of the springs may constantly alter the relations between the body and the running gear.

The gas circulation system is also indicated by letters, the parts being shaded in dotted lines. Here *K* is the gasoline storage tank, from which the liquid gasoline passes to the vaporizer float chamber, shown at *L*. From the float chamber it passes into the vaporizer mixing chamber, being there converted into gas by mixing with the air; and by the suction stroke of the piston, it is drawn into the combustion chamber through the tube, *M*, connected direct to the inlet valve of the cylinder. The tube, *J*, is fitted with a bell-shaped arrangement, which conveys hot air from the space surrounding the exhaust pipe to the mixing chamber of the vaporizer, thus insuring a perfect mixture of air and gasoline, as already explained in connection with the De Dion vaporizer.

The levers and connections controlling the gas and sparking systems are lettered as follows: Of the two directly opposite levers, shown at *R*, on the combined steering and control pillar, the upper one moves the link, *O*, bell crank, *N*, and the link, *H*, thus controlling the sparking. By moving this lever to the right the spark is retarded, by moving it to the left the spark is advanced. By this means the speed of the motor may be diminished or increased, as desired. The lower lever, *R*, regulates the quality of the gas and the quantity that is permitted to enter the motor cylinder. By means of link, *S*, its movement is communicated to a bell crank on the top of the vaporizer, as explained in connection with this instrument, thus enabling the desired variation of the gas and air inlets. This lever is the one used for controlling the speed of the motor by throttling the charge. It is the only governing action commonly used with this motor.

The Brakes and Speed Control System.—Fig. 384 similarly illustrates the connections and brakes of a speed controlling system. There are three powerful brakes on this carriage, one shown at the centre of the rear axle, at *K*, and the two auxiliary brakes fitted to the hubs of the rear wheels, at *I* and *I*.

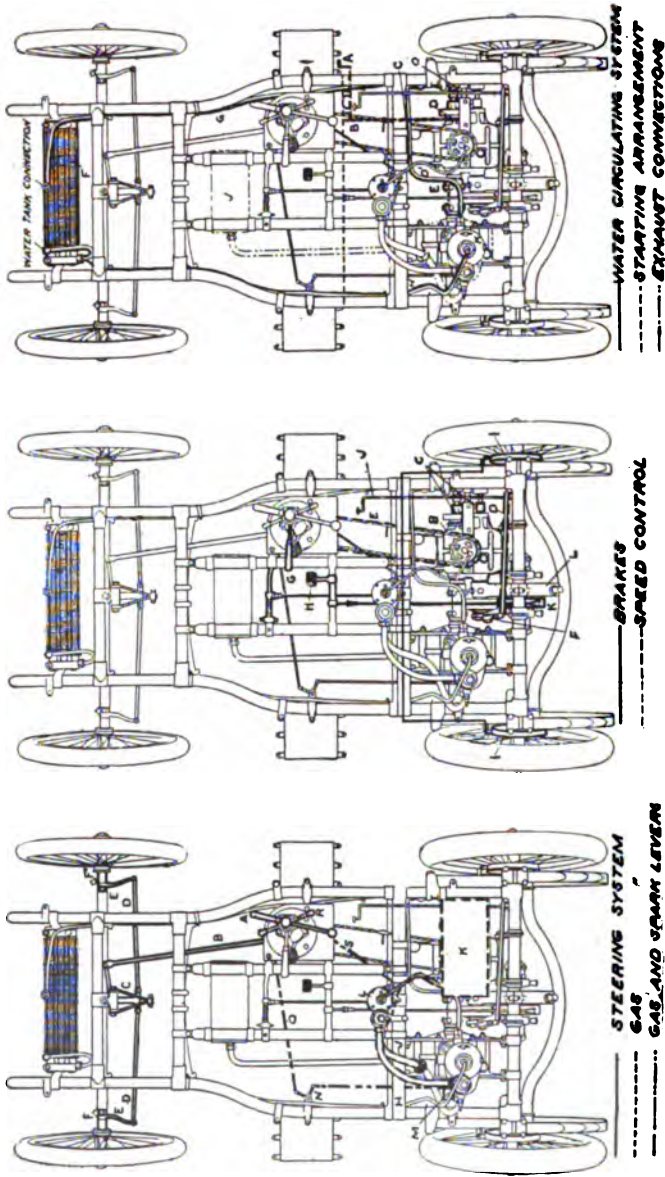

Fig. 883.—Diagram of the Steering and Gas Circulating System shown on the plan view of the De Dion Carriage, and of the levers controlling the gas supply and the timing of the spark.
 Fig. 884.—Diagram of the Brake and Speed Control Connections of the De Dion Carriage.
 Fig. 885.—Diagram of the Water Circulating System, the Starting Arrangement and the Exhaust Connections of the De Dion Carriage.

The band brake, *K*, on the differential drum, is operated by depressing the foot pedal, *H*, which rises through the floor of the carriage to the driver's foot. This brake releases itself as soon as the pressure of the foot is removed. To operate the auxiliary brakes it is only necessary to bring lever, *G*, to its natural position, thus throwing out both clutches, and then pressing down on the lever, which action depresses a vertical rod running in slides fixed to the steering standard. This motion, by means of simple lever connections, partially indicated in the diagram, thus compresses the bands on the brake drums, *I* and *I*.

As previously stated, the motor may be used as an effective brake, particularly on down grades, by interrupting the electric circuit at switch, *Y*, as shown in Fig. 332. Under usual conditions this act would cause the motor to stop, but when going down hill, with the clutch in gear, the motion of the carriage will drive the motor, exactly reversing the usual order. The air, being constantly drawn into the cylinder space, is compressed on the in-stroke of the piston, thus furnishing sufficient resistance to materially decrease the speed of the carriage.

The levers and links for controlling the speed and direction of travel are also indicated in this diagram. As already stated, the lever, *G*, in addition to its braking function, operates a clutch by a backward or forward motion. At the lower end of the rod, to which this lever is fixed, is a horizontal sprocket, for transmitting the motion given to the lever to the variable speed mechanism by means of the chain, *E*, to a second sprocket wheel, *B*. The position and functions of this sprocket have already been shown in connection with the description of the change speed gear. It actuates the clutches through a rack and pinion arrangement within the gear case.

The reverse is operated, as already explained, by means of a small positive clutch, *F*, which is operated by the rods, *H* and *D*, this clutch reversing the motion of the countershaft, under variable speed mechanism, as already explained.

Water Circulation and Starting.—Fig. 385 shows the connections of the water circulating system and starting device and the connections of the exhaust from the motor; the first being indicated by the full lines, the second by dotted lines, and the third by broken lines.

The water for cooling the cylinder of the engine by passing through the jacket space is contained in the supply tank built in the front of the carriage body, passing through the pipe, *G*, to the circulating pump, *O*, thence through the pipe, *O'*, to the cylinder jacket. The water enters the jacket through the side-port at the base of the cylinder, and then circulates as controlled by the heat of combustion, passing out through the port at the top of the cylinder, and forward to the radiating coils by way of pipe, *H*,

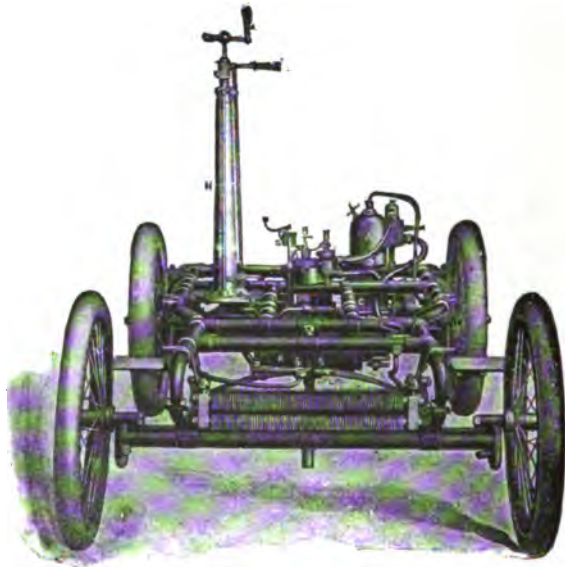

FIG. 386.—Front view of the Running Gear and Mechanism of a Typical De Dion Carriage. *A* is the motor; *B*, the vaporizer or carburetter; *H*, the combined steering and control pillar; *I*, the variable speed control and brake; *J*, the steering handle; *K*, the muffler; *L*, the radiating coil. This cut shows the relative position of the parts indicated in the last three figures.

whence it is returned to the supply tank through the connections shown at the left hand of the radiating coils. This arrangement of the jacket water circulation is typical for all carriages using centrifugal pumps.

The starting arrangements of this carriage are indicated by the dotted lines. As there shown, the small shaft is mounted in bearings fixed to the frame of the carriage body, to the outer end

of which is keyed the starting handle, *A*. At the opposite end is fixed a sprocket wheel, at *B*, which communicates the motion when the handle is turned by means of a chain, *C*, to the sprocket, *D*, on the main shaft, at the right-hand side of the change speed gear. From there, the motion is imparted to the crank shaft of the motor, through the coupling sleeve, *E*, the crank being turned until the engine has taken up its cycle, when the motor starts an automatic ratchet arrangement at the side of the

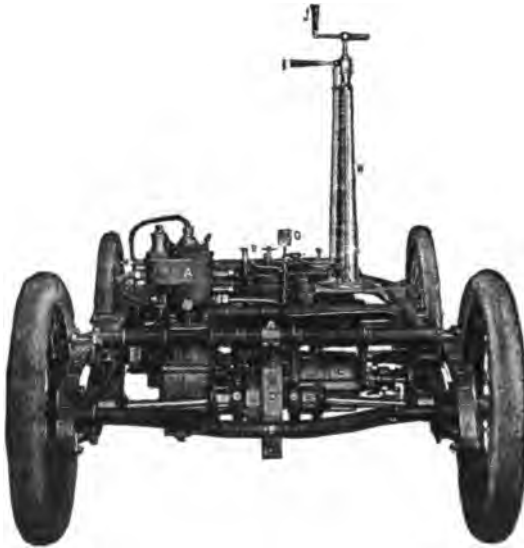

FIG. 387.—Rear view of the Running Gear and Mechanism of the Typical De Dion Carriage. *A* is the motor; *B*, the vaporizer or carburetter; *C*, the change speed gear; *D*, the differential gear, connecting to the universal jointed axle, described in connection with Fig. 80; *F*, the curved axle bar for maintaining rigid relations between the drive wheels; *G*, the pedal connecting to the auxiliary brake; *H*, the combined steering and control column; *I*, the variable speed control and brake handle; *J*, the steering handle.

sprocket, *D*, disconnecting the starting handle so that it remains stationary.

The exhaust connections of the motor are also indicated in this diagram by a system of broken lines. When the exhaust valve is opened, the burned out products of combustion rush through the exhaust port shown at *K*, through the pipe indicated by the broken line, to the muffler, *J*.



FIG. 888.—Duryea Four-Wheeled Gasoline Surrey.

CHAPTER THIRTY-FOUR.

SOME PROMINENT AMERICAN GASOLINE CARRIAGES IN THE ORDER OF THEIR DEVELOPMENT.

Duryea Engine and Carriage.—The engine used on the Duryea carriages is of the three cylinder type, each $4\frac{1}{2}$ bore by $4\frac{1}{2}$ stroke, giving, as is claimed, $10\frac{1}{2}$ B. H. P. at 600 revolutions. The three cylinders are cast in one piece, with water jacket surrounding the combustion chambers, which jacket has a single inlet opening at the bottom and single outlet for the mingled steam and water at the top, both connected with the water tank, placed higher than the water jacket, which permits a rapid circulation without the use of pump. As will be observed from the sectional drawings of this motor, the water jacket is of much less extent and capacity than that used on many other serviceable types of motor, as for example the De Dion, already noticed. This construction is purposely used to cool only that portion of the cylinder exposed to the most intense heat of the combustion, leaving the remainder of the cylinder uncooled in order that the temperature may be maintained at as high a point as possible during the expansion of the burned gases. The theory of the manufacturers is that since the heat is the source of energy, unnecessary cooling lessens economy and destroys efficiency, particularly at slow speeds, and much of the wide range of speed of the Duryea motors results, it is claimed, from the fact that the gases are not condensed by excessive cooling, but remain hot and powerfully expansive to the full end of the stroke, a fact of much importance in hard pulls at slow speed, as in climbing hills.

The ignition is by a primary spark, the electric current being supplied by a magneto generator driven from the fly-wheel. These generators are arranged to run at sufficient speed to cause ignition when the motor turns fifty or more revolutions per minute, while they are provided with a governor to prevent over-speeding, which device has been used by the manufacturers since 1896. One pole of the generator is grounded on the frame of the motor, while the current from the other is carried by visible

connections to insulated plugs or anvils let into the walls of the combustion space and provided with mica insulations. Binding nuts hold the anvils in place and insure tight joints, as shown in detail under the motor section. As shown in the sectional cut of the engine, a rocking contact breaker or hammer is pivoted in the exhaust valve stem and caused to oscillate by a pawl extending over the cam shaft, lifted at the proper instant by a cam shaped for the purpose. The lifting of the pawl brings the sparker hammer into contact with the insulated anvil, completing the circuit, since one pole of the generator is always connected with the motor. The sparker cam is abrupt on its rearward side which permits the pawl to drop, instantly, making a sharp break and producing a strong, hot spark. The operation of the exhaust valve comes at a different time, so that the sparker operation is not interfered with; while removing the exhaust valve likewise removes the sparker hammer and permits inspection when needed. The insulated anvils are connected in multiple to the single wire, marked *B* on the accompanying cut, and the electric arrangements are not different in other particulars from the mechanical generator systems now being used by others, as for example the Mors carriages.

Governing and Balancing the Motor.—The motor is operated without automatic governing mechanism, the sole method of regulation being by a single throttle slide, marked *A* in the accompanying view of the engine, by which the amount of opening of the inlet valves may be controlled, varying the quantity of fuel supplied, and thus modifying the speed of the engine through a wide range. The cranks are set 120 degrees apart, giving a perfect mechanical and an excellent torsion balance, which, together with the light and compact construction, not only secures light weight with great power and long life, but immensely reduces the vibration of the carriage. As already stated, the vibration due to the compression of a gasoline engine is usually found to vary inversely as the square of the number of cylinders used, which would give about 1-9 the total vibration with a three-cylinder engine that would be experienced with a one cylinder of like power. A further advantage is that of increased reliability—for it is evident that all three cylinders are not likely to go wrong at any one time—so that the carriage

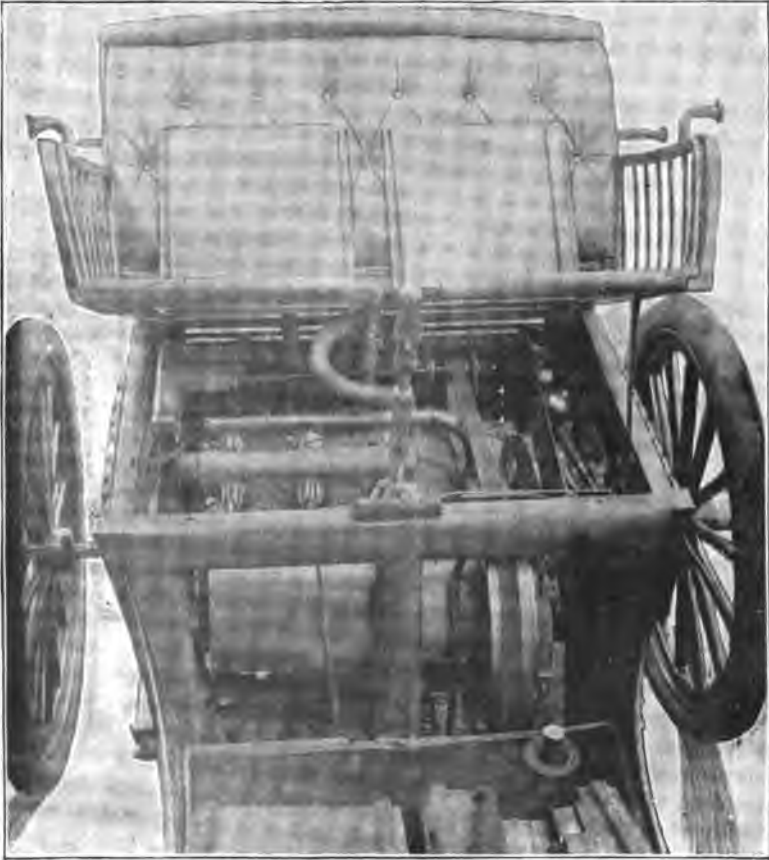

FIG. 389.—View of the Motor and General Mechanism of a Duryea Carriage, giving an idea of the ready accessibility of the parts. The single lever for combining the three functions of steering, throwing on the clutch and throttling the engine is shown rising to the front of the seat.

may be driven with the remaining one or two, as the case may be.

The mixture of liquid fuel and air is led to the motor through the pipe across the heads, passing downward through the inlet valves into a port chamber which serves both the inlet and exhaust valves. Removable peep caps open into this chamber, permitting the condition of the valves or the size of the spark to be inspected at will; one or two caps being removed while the remaining cylinder furnishes the power. From these chambers the exhaust gases pass to the single exhaust tube, *C*, and thence to the muffler. The cylinder heads are readily removed by unscrewing, as shown in the section. The combustion chamber is



FIG 390.—The Duryea Three-cylinder 10 $\frac{1}{2}$ B. H. P. Carriage Motor. *A* is the throttle slide, by which the gas supply to the three cylinders may be controlled by the combined steering and control lever shown in the last figure; *B*, single wire connecting anvils of the three sparking plugs in multiple, the other terminal of the circuit being connected to the middle parts of the cylinder; *C*, the common exhaust tube conveying the burned out gases to the muffler; *D*, the pipe conveying air to the jackets of the three cylinders.

spheroidal in form, securing cubic capacity with minimum wall surface, thus economizing heat and insuring great strength of parts. Large bearings readily adjustable are provided, lessening cost of repairs and facilitating a removal of parts.

The simplicity of construction manifested in this motor is also embodied in the other parts of the vehicle. The transmission or "power gear," as it is called, is journaled on the motor shaft by the side of the fly-wheel, which secures the very desirable feature of driving direct from the motor shaft, with the consequent economy of power. This transmission, as already explained, allows two speeds forward and a reverse, although all or-

dinary driving is done on the high speed, the parts of the power gear being stationary with relation to each other, and the speed of the carriage being controlled entirely by the act of throttling.

The most interesting feature of this carriage is the single central controlling lever, by which the three different functions of driving the vehicle—steering, throttling and setting the clutches—are easily and readily performed by one hand. This lever consists primarily of an outer tube $1\frac{1}{8}$ inch diameter by

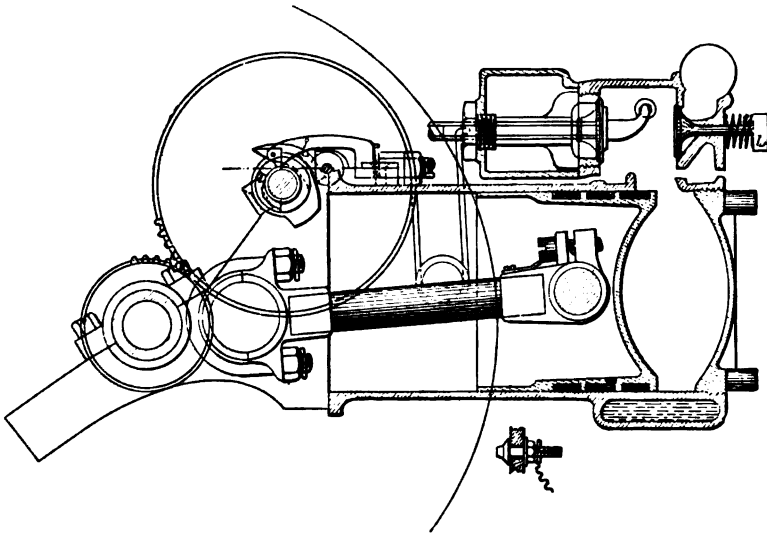

FIG. 301.—Sectional View through one Cylinder of the Duryea Carriage Motor, showing working parts. The exhaust cam operated by a 2 to 1-gear system from the main shaft, imparts a double motion to the valve pushrod; a lift for opening the valve, and a double twist for making and breaking the connections of the electrical spark. The valve and sparking chamber is projected so as to show the position of contained mechanism on a plane different from that of the cylinder section. Details of the insulated sparking anvil are shown below the cylinder. It is an iron contact point, having a mica washer on the inside and the outside of the cylinder walls, and a mica bushing between, so as to perfectly insulate it from the metal of the engine. A very short water jacket and the concave cylinder and piston heads are also exhibited in this figure.

about 10 inches in length, fixed at its lower end into a pivoted casting adapted to swing crosswise the vehicle. This pivoted casting is constructed with arms extending outward and slightly downward at angles of about 30 degrees, which arms have their ends connected by chains, or similar tensile connections, with suitable arms on the front wheel or wheels; the proportions be-



FIG. 382.—Duryea Four-Wheeled Gasoline Phaeton.

ing so arranged that a convenient movement of the steering lever produces the proper angularity of the steering wheel. Within the outer tube forming the controlling lever is a bushing having an internal circular groove about midway in its length, as will be described later. Through this bushing slides a smaller but longer tube, which carries a suitable handle at its upper end, and a pinion, about $3\frac{1}{2}$ inches long, at its lower end. This pinion engages a rack placed crosswise the vehicle, in the line of the steering pivot, and by rotating the handle, shifts the rack, which, by means of a lever at the side of the carriage, imparts motion to the throttle slide before mentioned. Thus is obtained a simple, reliable and handy means of controlling the motor while steering. This rack and pinion are so designed that inclining the steering lever does not interfere with the operation of the rack, the teeth of which are specially cut so as to permit oscil-



FIG. 393.—The Duryea Self-oiling Sprocket Drive Chain. The body of each link is bored out as shown, and a plug of felt inserted in the opening. The felt absorbs oil readily, at once thoroughly lubricating the moving parts and increasing the tightness of its own adhesion. This feature insures a noiseless chain.

lation without binding. The length of the pinion and the inner tube are such as to permit an up-and-down movement of the handle and tube, and the pinion is connected by a swivel passing through its centre with the arc-shaped end of the clutch operating lever, terminating below the steering lever pivot. A downward motion of the controlling handle sets the low-speed friction band, while an upward motion sets the high-speed clutch. Midway between the two limits both clutches are free and the motor may run without driving the vehicle. To guard against accident a catch is provided to engage the circular groove inside the bushing mentioned and maintain the controlling handle in the "off" position until this catch is released from the groove by pushing a button in the controlling handle. This arrangement secures safety from accidental starting, which might otherwise be possible in mounting or leaving the carriage. Since the motor has

ample power to drive the carriage over all ordinary roads with the high clutch engaged, and without the use of the low speed, the control of this vehicle is seen to consist in steering and throttling only. The former function is accomplished by swinging the lever sidewise; the latter, by twisting the handle. Not only is it possible to perform these simple functions with one hand, from either side of the vehicle, but either hand, or, if occasion requires, both hands may be used, enabling a lady or a child to readily control these vehicles.

All the mechanical parts of this carriage are accessible from the top for inspection or repairs, and any part may be removed in a very short time, thus achieving a degree of accessibility not approached by most machines. This feature is shown in accompanying cut, wherein the great simplicity of construction appears, with other desirable features, such as absence of countershafts, as already mentioned, and of complicated transmission gear or underframe, which so greatly adds to the weight. The steering connections are very positive and easy of operation, while, by the use of tensile connections only, the elastic effect and lost motion, so frequently met with in other arrangements, are completely obviated. Other excellent features of this carriage are its low centre of gravity, the machinery being all below the top of the rear wheels, while the seat is on a level therewith. The long wheel base, the great distance between the passengers and the steering wheels, the long and flexible springs and the large wooden wheels and tires, all contribute to the end of easy riding at good speeds.

The Haynes-Apperson Carriage and Mechanism.—One of the best known, as well as one of the earliest, American gasoline carriages, is the Haynes-Apperson, which first came before the public as a practical reality in 1893-94. In almost all particulars this carriage represents a peculiarly American activity in design and construction. The motor used is a double opposed cylinder, horizontal type, with the crank set at 180° , thus involving that the two pistons make their in-strokes and out-strokes contemporaneously, insuring an explosion once in every revolution, and securing perfect balance of the moving parts. The manufacturers are strong advocates of the opposed double cylinder horizontal type of engine, asserting that its construc-

tion has been found best suited to the ends of overcoming vibration and securing easy operation. According to their published statement, one of their carriage motors may be connected to operate an electric light dynamo, and will run without any perceptible variation in voltage, even when the connection is direct to the main shaft.

No attempt is made to control the speed of the engine by an automatic governor, the method employed being to throttle the charge, thus insuring only such proportionate mixtures as are required for the amount of speed or power desired. Two carburetters are employed, one for each cylinder, the design being of the ordinary float-feed variety, both being fed from the 10-



FIG. 394.—Double Opposed Horizontal Cylinder Motor of the Haynes-Apperson Carriages. The two cylinders of this motor are somewhat offset, as shown in the cut, the crank rods working on two cranks. The long crank shaft shown at the front of the engine is for carrying the change speed gear already described. The reciprocating parts are lubricated by adjustable oil feed cups shown at the top of each cylinder. Ignition is by break contact spark, the exhaust connections being on the same plan as those described for other motors.

gallon tank under the front seat. The operation of the throttle in each of them is to reduce the gasoline aperture to the required degree, both being operated by the same throttle lever, which connects to a button coming through the floor of the carriage under the driver's foot. The ignition is by a break contact spark, the current being generated by a Holtzer-Cabot magneto. By the method of throttling the charge, which is so successful a feature in most American gasoline carriages, the speed of the motor may be changed from 200 to 800 revolutions per minute. There is, however, in connection with this carriage, a somewhat complicated, although highly efficient, speed changing gear, which has already been described. By throwing on the proper

clutch the speed and power ratios between the main shaft and the countershaft may be varied from $3\frac{1}{2}$ miles per hour on the first gear to 9 miles on the second, and 15 miles on the third; with a reverse at about 3 miles per hour.

The Haynes-Apperson Driving Gear.—The system of power transmission employed on the later patterns of this carriage is worthy of mention as among the most ingenious and efficient contrivances for securing a steady drive, independent of all the

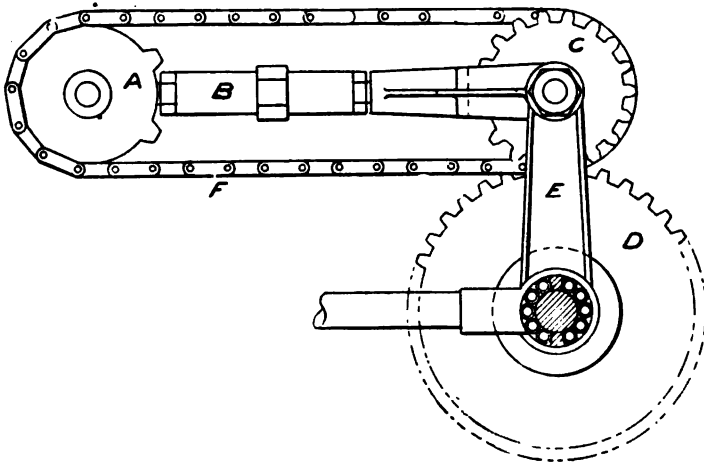

FIG. 335.—The Haynes-Apperson Transmission. A is the sprocket fixed at one end of the counter shaft; B, a turnbuckle on the adjustable distance rod between the first counter shaft and the second counter shaft carrying the pinion, C; C, a spur pinion keyed to the second counter shaft, carrying a sprocket driven by a chain from A; D, a spur gear on the rear axle meshing with spur pinion, C, on the second countershaft; E, a rigid distance rod for maintaining fixed relations between the spurs, C and D. The advantages of this system are the maintaining of a steady drive without the usual wear and tear on the moving parts, consequent on sprocket connections direct from the first countershaft, or from the main shaft of the motor.

vibrations of travel. The sprocket at the end of the secondary shaft, driven from the main shaft by the system of gearing already mentioned, drives the second countershaft situated directly over the rear axle. Between these two shafts is a distance rod, whose length may be adjusted by a wrist nut, or turnbuckle, so as to take up the slack of the chain or allow it to be loosened, as required. On the end of the second countershaft is a spur pinion, which meshes with a spur gear on the differential drum, thus imparting power to the drive wheels. The advantage of

this arrangement is obvious, since the up and down movement of the distance rod, with the vibrations of travel, throws no strain on the springs, as is frequently found to be the case with the simple sprocket or spur drive connection between the rear axle and the countershaft. The arrangement seems to have achieved the desired end quite as readily as the European method, already noted, of driving each of the two rear wheels separately from the countershaft.

Steering Gear and Underframe.—The steering is by hand lever or tiller, coming to the right hand of the driver, and the pivoted axles are of the double yoke pattern, described in connection with Fig. 36. Among other distinctive features of this carriage, it may be remarked that almost from the beginning of



FIG. 306.—Familiar Model of the Haynes-Apperson Carriage, seating two people.

its manufacture it has been equipped with wooden wheels, which is a procedure contrary to the rule among American motor carriage builders, although the popularity and good records of this carriage have amply demonstrated its wisdom. As at present constructed the underframe consists of two solid perches or reach rods connected to either extremity of the rear axle and coming together to form a swivel-jointed connection at the centre of the forward axle. The body frame is of angle iron, having transverse tubes at the rear end for attaching the motor and gearing.

The Winton Carriage and Mechanism.—The Winton motor carriage, which enjoys a high reputation, both for speed and endurance, is a very compact and efficient machine. The engine

is of the horizontal single cylinder type, and is mounted on the body frame, to which it is rigidly connected at the front and rear, as shown in an accompanying cut. It is especially notable for one feature of its construction and operation—governing the speed of the motor by an automatic air-pressure device, controlling the operation of the gasoline feed valve of the cylinder. The details are as follows: a small air pump, driven by a connecting rod from an eccentric on the main shaft, which is fixed

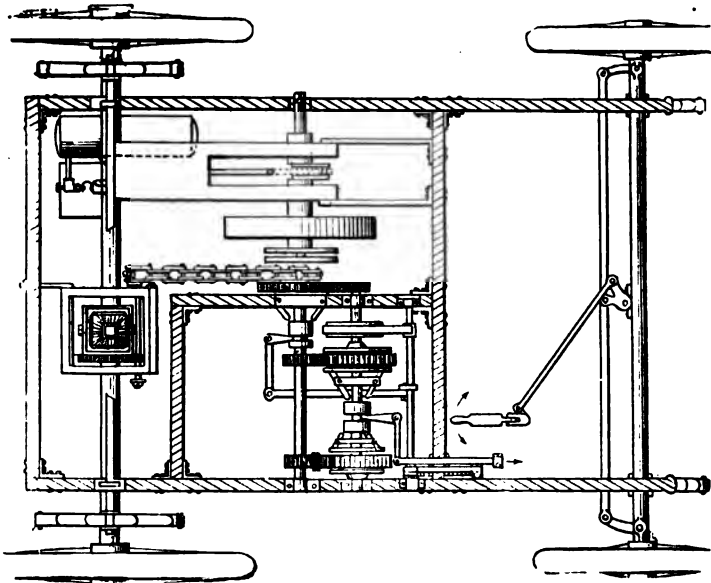

FIG. 397.—Plan of Running Gear and Mechanism of One Model of the Winton Carriage, showing the single cylinder motor, driving connections, change speed gear and steering system. The change speed gear, already explained, is operated as shown by the two levers figured at the base of the cut: the lower one operating the clutch on the main shaft for giving the first speed, also for throwing on the brake; the upper one operating the two clutches on the counter shaft, for giving the second speed and reverse. The steering lever as shown is connected by a link to a bell crank, which moves a drag link connected to the steering arms of the two forward stud axles.

at 180° from the crank, constantly supplies air to a special reservoir, where it bears upon a piston fixed at the end of the rod of the cylinder inlet valve, so that, according to its pressure it can control the amount of fuel admitted to the combustion space. The operation is very simple and reliable, since the air, behind the piston just mentioned, can escape only when the push



FIG. 398.—Winton Tonneau Touring Carriage, showing tonneau attached.

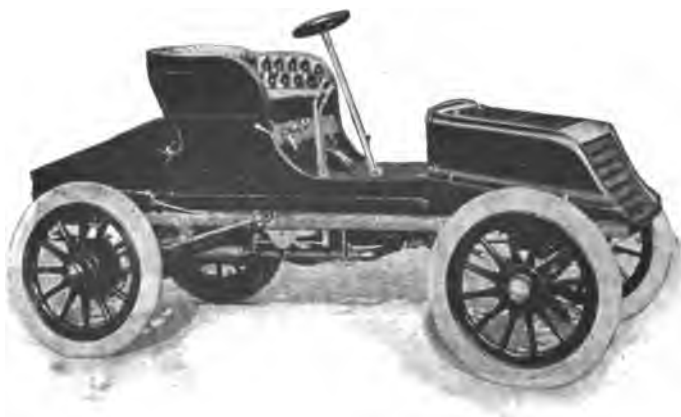

FIG. 399.—Winton Tonneau Touring Carriage, showing tonneau removed.

button, coming through the floor to the driver's foot, is depressed. It consequently follows that when the speed of the engine has exceeded a certain predetermined limit, the air exhaust cannot take place with sufficient rapidity to enable the usual operation of the feed valve to continue; hence it acts as a cushion or spring, resisting the opening of the feed valve until the speed has again sunk to its proper point. By pressing on this button the speed of the engine may be varied through a range between 100 and 800 revolutions per minute.

The carburetter used with this engine, which is of the general

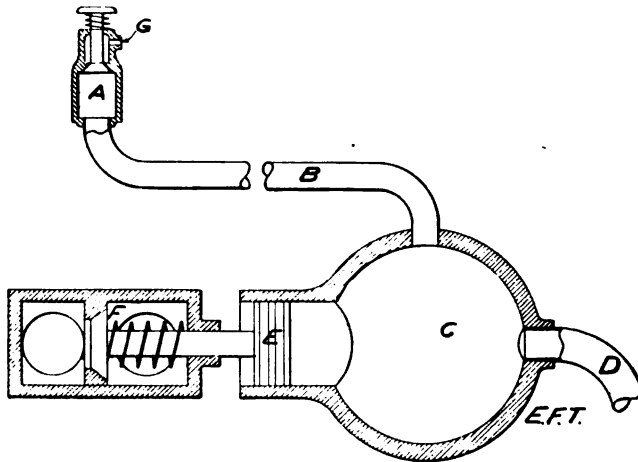

FIG. 400.—Diagram of the Winton Pneumatic Speed Control System. A is the valve chamber from which the air is exhausted through the vent, G, by pressure on the foot button at the top of the valve rod; B, a tube connecting chamber, A, with air reservoir, C; D, tube leading from the air pump operated from the main shaft of the engine, and forcing compressed air into the reservoir, C; E, the piston attached to the spindle of the inlet valve, F, and controlling the opening of F, according to the degree of compression maintained within reservoir, C. By this mechanism the opening of the inlet valve, and consequently the fuel supply, is regulated within definite limits, and the speed varied as desired.

type already described in connection with the figure of the James mixing valve, admits of a suitable range of adjustment. The ignition is by a make and break device on a primary circuit, the spark being produced by a snap cam, somewhat after the manner of several other devices already described. The current is supplied by either one or two batteries of dry cells, which may alternately be connected to the circuit by buttons under the driver's seat.

The driving connections are direct from the sprocket, keyed to a sleeve on the main shaft, to another sprocket on the differential gear drum on the rear axle. The operation of throwing on the power, or of changing the speed or power ratios, as desired, is accomplished by two friction clutches, while the reverse is obtained by a third clutch, as already described. The adjustment of the transmission is regulated by two distance rods, one at either side of the carriage, between the body of the running gear. The two axles are connected by two reach rods arranged to form a triangle, whose apex touches the centre of the forward axle, where a swivel joint is made, giving the required flexibility on uneven roads. The body frame, resting above the springs, is constructed of seasoned oak, joined at the corners by iron angle pieces. The wheels, as in many of the older makes of carriages, are of the wire spoke variety. The steering in the latest models is controlled by a hand-wheel actuating an irreversible worm gear, somewhat after the design of the Panhard carriages, as shown in Fig. 48. With the exception of this steering wheel, the carriage is entirely controlled and operated by two levers rising to the right hand of the driver. The longer of these two, when drawn back, connects the driving gear and motor, and, when shifted all the way forward, applies a powerful brake to the differential drum. The shorter of the two levers operates the speed changing and reverse gear; one pull back throwing in the reduced or hill-climbing gear, and one pull forward engaging the reverse. In addition to the brake, already mentioned, there is a special emergency brake, operated by a foot pedal, which is to be used only when the lever fails to operate.

The St. Louis Light Carriage.—The St. Louis gasoline motor carriage is another well-known and excellent type of single cylinder machine. As shown in the accompanying illustrations, giving details of the arrangement of the machinery, it counts simplicity among its excellent features. The single cylinder engine has a bore of $5\frac{1}{4}$ inches and a stroke of 6 inches, and is rated at 7 H. P. A desirable feature lies in the fact that the change gears are located in an extension of the crank case, thus insuring a fixed distance between the main and secondary shafts. As shown in the lettered diagram of the assembled engine, a

friction clutch, *C*, operated by a lever, *B*, connects the spur wheel, *A*, on the main shaft, with another spur, *D*, on the first driven shaft, thus throwing in the power upon the carriage. The change speed gears already mentioned, are, as may be seen in

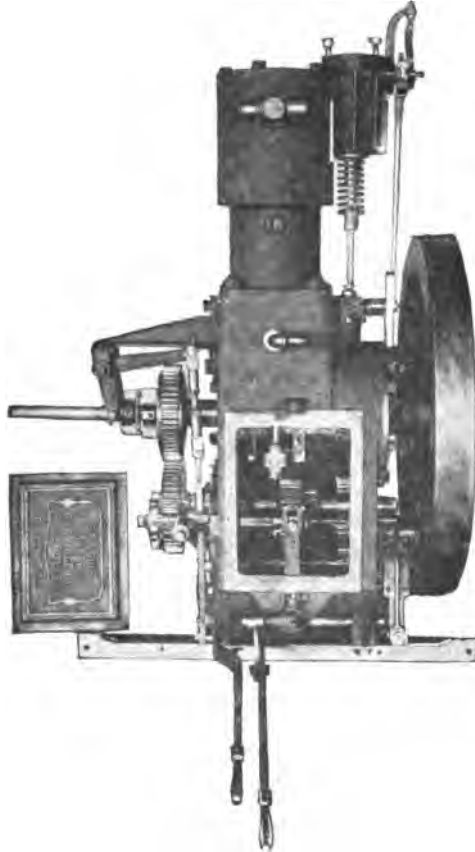

FIG. 401.—Single Cylinder Motor of the St. Louis Gasoline Motor Carriage, showing control levers and the variable speed gear contained within the case below the crank.

the cut, of the ordinary sliding-shaft spur gear type, and are operated by a lever, marked *E* in the diagram, which transmits its motion to a bell crank, thus shifting the double faced sliding pinion in either direction, as desired. By the proper connection

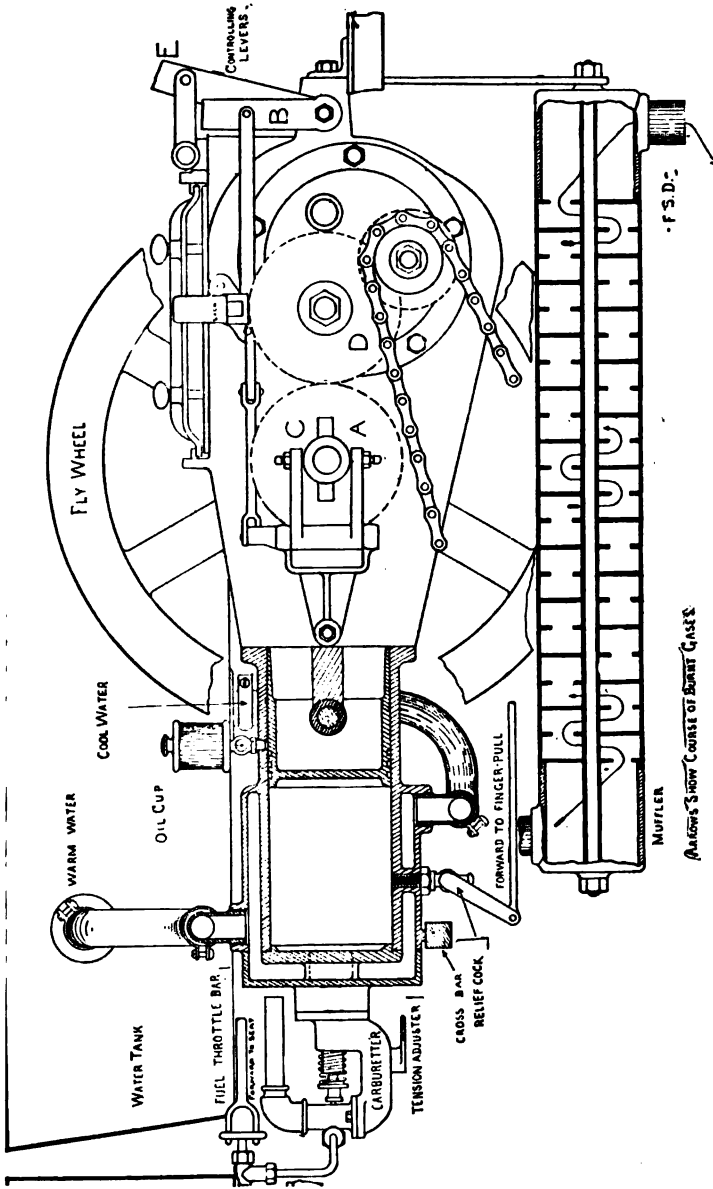

FIG. 402.—Diagram of the Motor and Mechanism of the St. Louis Gasoline Carriage, showing working parts in position. A is a spur wheel on the main shaft, meshing with spur, D, on the second motion shaft; B is a lever for operating the clutch C, thus connecting A rigidly to the main shaft and enabling its motion to be transmitted to spur D on the counter-shaft; C is a friction clutch, connecting spur A rigidly with the main shaft; E is a lever operating the variable speed by sliding the speed changing gears on the second motion shaft. It is connected through a bell crank with a double-faced sliding gear, as shown in the cut of the engine.

of the double faced pinion, two forward speeds may be obtained, and also a reverse, by throwing the larger pinion into mesh with the idler on the third shaft, in somewhat the same manner as other speed gears, already described. One particularly commendable feature of this device is that the spindle of the sliding gear extends outside of the casing of the engine, there meeting the link-bar of lever, *B*, which throws on the main clutch, as already described. At their point of contact is a locking device, which renders it impossible to shift the gears operated by lever, *E*, until the main clutch has been thrown out. The position of this automatic lock is indicated in the diagram, already

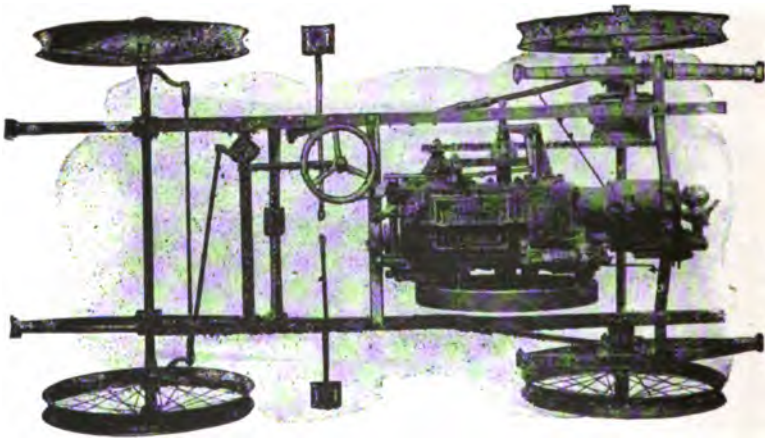

FIG. 408.—Plan View of the St. Louis Gasoline Carriage, showing motor and mechanism in position.

mentioned. This arrangement effectually provides against annoying jolts, when the carriage is operated by unskilled drivers, and is also an efficient and desirable means of saving the gears. The rear end of this cylinder, as shown, is hung by an arched crosspiece on the underframe, the front end being similarly attached to another crosspiece, midway in the length of the carriage. The springs, which are arranged in the length of the carriage, are attached to roller bearing boxes on the axles, being, in fact, hinged at top and bottom. The strain of driving is relieved by two adjustable distance rods, connected to the rear axle, below the springs at one end, and to the longitudinal perch rods of the frame at the other.

The water circulation is controlled entirely by gravity, as indicated in the full-page diagram, the water jacket covering the entire length of the stroke. The carburetting device is in an adjustable mixing valve, the charge being throttled by a needle valve, controlled by a link passing forward to the driver's seat. The ignition is accomplished by a break contact spark on a primary circuit, the current being furnished by a small dynamo, resting upon the engine cylinder and operated by a brush pinion from the fly-wheel. The lead of the spark may be varied by pressure on another foot button, whose connections are not indicated. The body frame, as shown, consists of a nearly complete quadrilateral of angle iron, which, however, forms the sole connection between the axles in the lighter models of this carriage. The brake connection is direct from the driving shaft on the enclosed gear case, to the differential drum, shown near the right hand extremity of the rear axle. The brake band is applied to this drum by a link connecting to the rocking shaft operated by lever, *B*, the operation of throwing out the clutch and throwing on the brake being simultaneously accomplished, when this lever is thrown forward. An auxiliary brake, equipped with cast-iron shoes, is operated by a pedal coming to the driver's foot. The steering is by a hand-wheel, or an inclined pillar, the connections being by a spur pinion and toothed sector.



FIG. 408A.—A Duryea Three-Wheeled Gasoline Phaeton.

CHAPTER THIRTY-FIVE.

SOME RECENT AMERICAN GASOLINE CARRIAGES.

The Packard Gasoline Carriage.—Among the excellent specimens of carriage design, produced in America, may be mentioned the Packard carriage. Like several others, already noticed, it is propelled by a single cylinder motor, ignited by a jump-spark and water cooled by gravity circulation. The speed may be controlled up to 850 revolutions per minute, by a pedal coming to the driver's foot, and regulating the operation of the inlet valve. In addition to this method of control, there is also



FIG. 404.—The "Packard" 12 H.P. Tonneau Carriage, showing tonneau attached.

a very ingenious centrifugal governor operating from the cam shaft to the motor, which at high speed modifies the spark to any required point, or prevents it altogether. This result is accomplished by a sliding sleeve, actuated by the centrifugal governor, which moves a variable cam across the periphery of a roller wheel attached to the trembler on the coil. When the speed of the motor exceeds a predetermined limit, the cam overruns the roller and ignition is prevented. Another interesting and novel feature of this carriage is the spring transmission clutch,

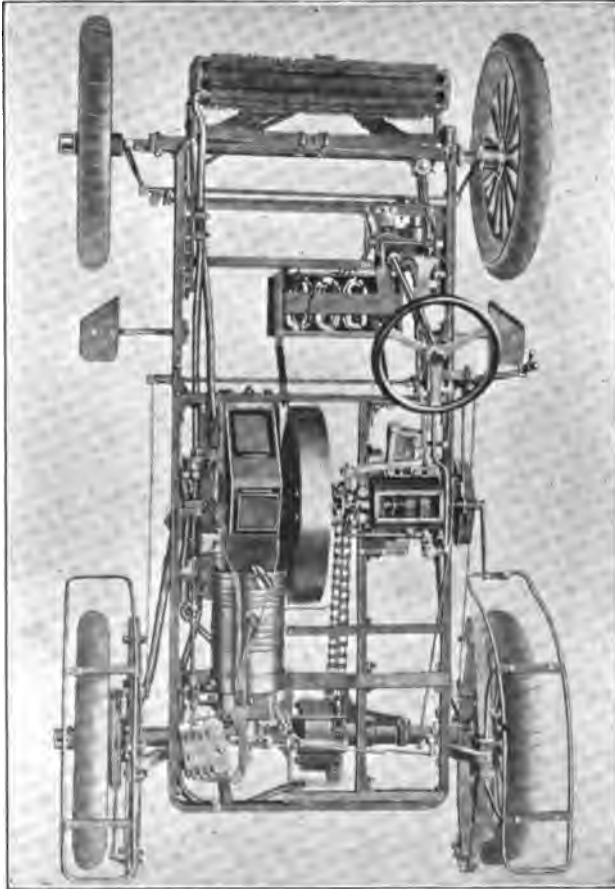

FIG. 405.—Plan of the "Packard" 12 H.P. Tonneau Carriage, showing motor and mechanism in position.

which is forced directly against the face of the fly-wheel, operating, as claimed, to insure smooth running and ready transmission with the minimum of vibration to the body. The spring of the cam absorbs the greater part of the jar and vibration, which would otherwise be transmitted to the wheels and running gear. The speed-changing gear is of the familiar sun and planet type, giving three speeds forward—10, 20 and 30 miles per hour—and a reverse, the operation of this instrument, as well as throwing on the main clutch, being accomplished by a single lever, arranged to slide in two parallel slots, having a central connection,

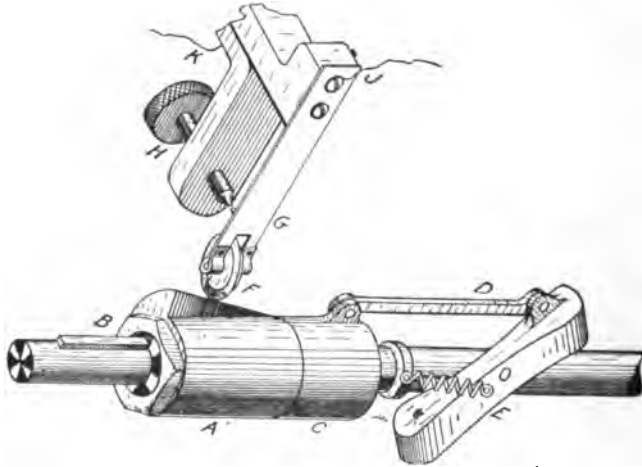

FIG. 406.—The Sliding Cam Ignition Governor of the "Packard" Carriages. A is a sleeve sliding on a feather, B, on the rotating shaft, being connected by link, D, to the governor weight, E, so that the throw of the cam, F, may be varied from maximum to zero, as the speed of the motor increases. Cam, F, bears upon the roller carried on the end of the vibrating leaf spring, G, modifying the electrical contact between the terminals, J and K, according to the throw of the cam and the adjustment of the screw, H.

which gives the familiar H-shaped channel used on several other carriages. The running gear of the Packard carriage is approximately rectangular, with stay rods joined to the framework of the differential gear on the sleeve of the rear axle. The perch rods are ball-jointed at front and rear to give the desired flexibility to the carriage. A peculiarly noticeable feature is the manner of applying the emergency brake, which has been adopted in very few, if any other, carriages. Instead of operating by pressing a band or suitable contact shoes against a brake drum

on the wheel hubs, the brake shoes bear upon the inturned flange on the wheel rim, thus realizing, as is claimed, a much greater retarding force, and being effectual to entirely prevent skidding. They are operated by wire rods connected at the front of the carriage to a foot pedal in front of the driver's seat.

The manufacturers of the Packard carriage are thorough advocates of the single cylinder motor disposed to the rear of the driver's seat on the body frame, claiming that the undue vibration and other troubles urged against this type of motor, by some manufacturers, are entirely obviated by the improved construction of up-to-date machines. They also claim a decided

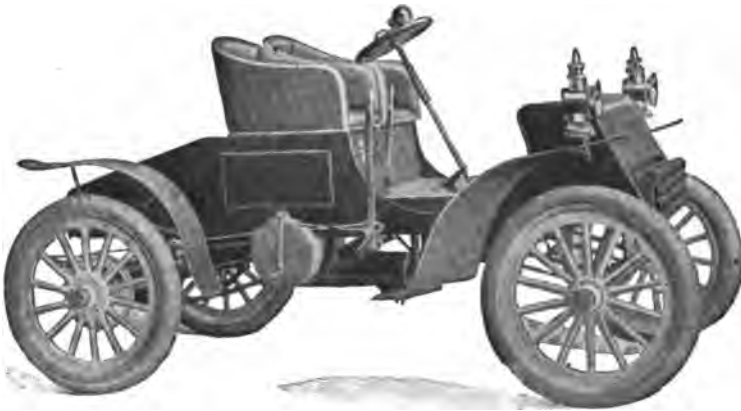

FIG. 407.—“Packard” 12 H. P. Tonneau Touring Carriage, showing tonneau removed.

advantage in the underhung engine, which brings the fly-wheel and main weights near the centre of the car, to the advantage of stability and the proper distribution of the load. This end achieved, they claim that freedom from skidding and the maximum of traction efficiency is attained, much more readily than is possible with the models of carriage having the motors set in front, after the Panhard and Daimler models.

The “Peerless” Gasoline Carriage.—The “Peerless” motor carriages, several styles of which are shown in accompanying illustrations, are, so far as general appearances go, among the closest approximations to the best European models that are

made in America. Following the most approved designs of Panhard and Daimler, the motor is placed at the front of the frame beneath a suitable forestructure or bonnet of familiar design. The underframe is also closely approximated to these gasoline carriages, in the fact that it is of unusually strong and rigid construction, being formed throughout of channel iron bars in the manner familiar in railroad locomotives. In the point of long wheel base is to be seen another excellent feature adopted from French prototypes. In several other respects, however, the carriages approximate the De Dion models and some of the usual American theories of construction, in that the driving connec-

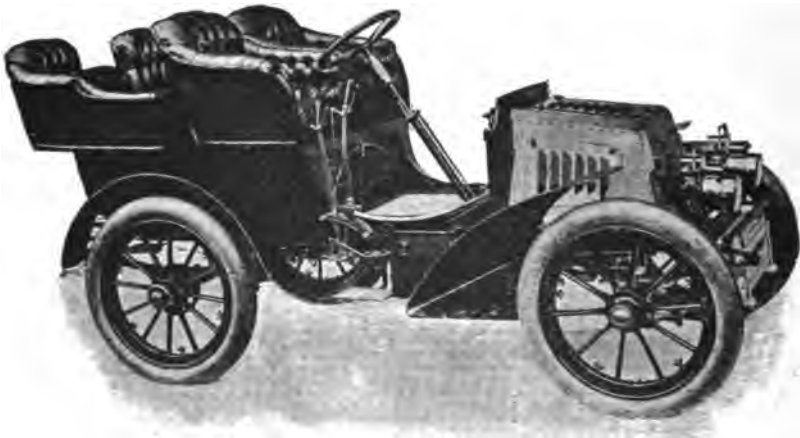

FIG. 408.—One model of the "Peerless" Gasoline Carriage, equipped with wooden wheels and removable tonneau.

tions are by bevel gear direct to the centre of the divided rear axle, instead of by sprocket from the extremities of the counter-shaft, to each of the rear wheels.

The Motor and Parts.—The motors used in the carriages shown in the accompanying illustrations are of the double cylinder vertical type, with an enclosed crank case, and contain several excellent features of construction. Among these, may be mentioned the fact that the crank discs, or enclosed fly-wheels, run in an oil bath, with devices for automatically lubricating the

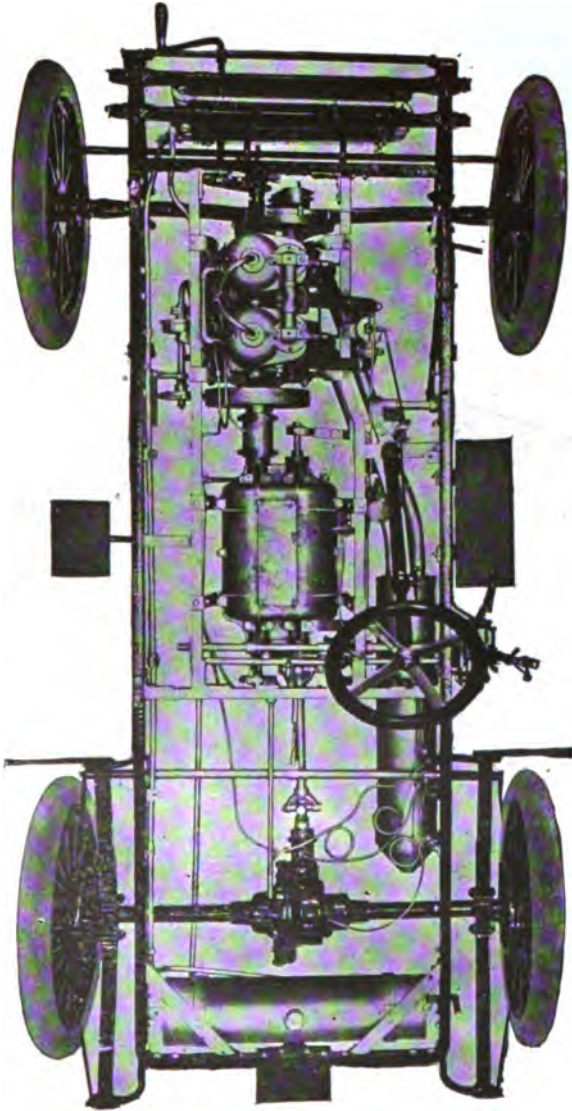

FIG. 409.—Plan of the "Peerless" Carriage, showing position of the motor and mechanism.

cylinder and piston by the splashing method. The vertical position of the cylinder enables the entire circumference of the bore to be uniformly lubricated by the wiping of the piston rings; at the same time preventing the difficulties incident upon excessive lubrication, which is a prolific source of obnoxious odors and other annoying features, and has been provided against in various improved designs of automatic oilers.

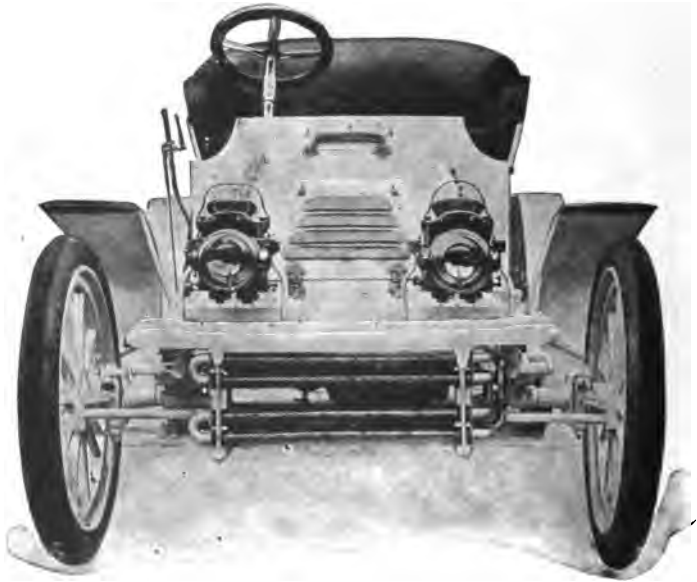

FIG. 410.—Front view of "Peerless" Tonneau Carriage, showing the radiating coils and bonnet for covering the motor; inclined steering pillar with hand-wheel and control levers at the right of the driver's seat.

The Running Parts and Speed Gear.—The other running parts of this carriage, outside of the engine proper, are lubricated by sight-feed oil cups, supplied by a pressure pump operated from the front of the driver's seat, thus rendering it unnecessary to dismount for the purpose of oiling, except under exceptional conditions. The water-jacket circulation of the engine is controlled by a centrifugal pump, operated from the fly-wheel, which forces the jacket water exhaust through radiating coils disposed at the front of the car. The change-speed gear operated from

the lever, at the right of the driver's seat, gives three speeds forward and a reverse, together with a simultaneous advancement or retard of the spark, thus regulating the speed of the motor to suit the requirements of the desired rate of travel, without unnecessary expenditure of power. Ignition is by jump-spark, controlled by a specially-designed vibrator on the induction coil. Both the primary and secondary circuits are completed through heavily insulated wire cables, which effectually obviate all danger of short-circuiting in damp weather.



FIG. 411.—Rear view of the "Peerless" Tonneau Carriage, showing the tonneau attached; also door for admitting passengers. This cut shows the arrangement adopted for all carriages having a tonneau for the rear seat.

The Steering and Spring Compensating Devices.—The steering is by means of a hand-wheel, which, by an ingeniously arranged knuckle-joint sleeve, may be bent forward to prevent interference as passengers enter the carriage; also enabling the wheel to come well into the driver's lap, where a very much more positive grip is rendered possible than with the long reaches necessary with some other types of inclined steer-

ing pillar. All four wheels are pitched inward, with the result that the steering is rendered easier and more positive. The pitch of the rear wheels is made possible by a flexible rear axle, of the same general type that is used in the De Dion carriages. As indicated by the accompanying illustrations, both wire and wooden wheels are used. A removable tonneau increases the carrying capacity from two to four passengers, whenever desired.

The "Dyke" Carriages and Motors.—The widely advertised Dyke carriages include several patterns of both light and

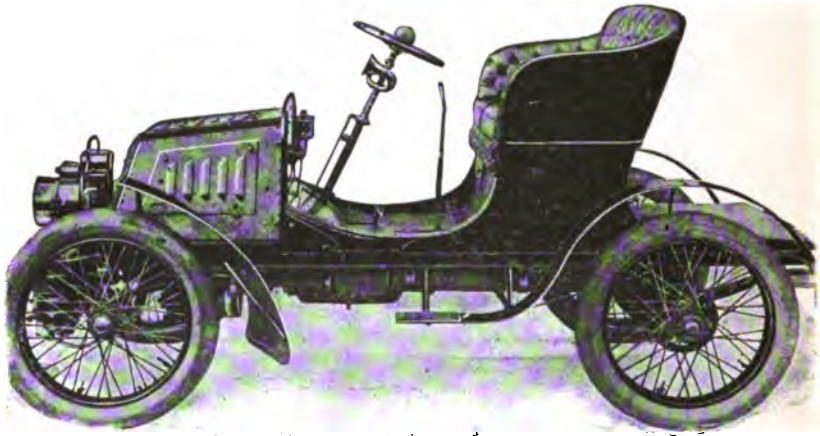

FIG. 412.—Another model of the "Peerless" Carriage, with tonneau removed. This carriage, unlike that previously shown, is equipped with wire wheels after the usual American custom.

heavy vehicles, which, as shown by the accompanying illustrations, combine several excellent features of construction. The 6 H. P. Tonneau carriage is equipped with a single cylinder motor, attached to the shaft of which is a system of shifting change speed gears, which drive a countershaft through bevel connections. At the end of the short countershaft is a sprocket pinion which drives direct to the differential drum on the rear axle. The running gear of this carriage, as well as that of the lighter models, is particularly noted for its strength and simplicity, consisting of a rectangular framework of angle iron with

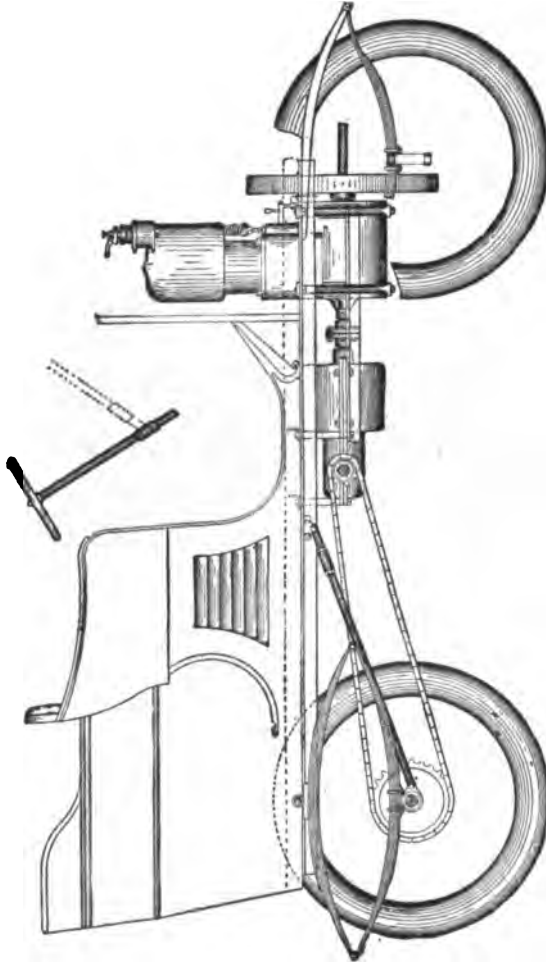

FIG. 418.—Side view diagram of the "Dyke" 6 H. P. Tonneau Carriage, showing motor and transmission gear and hinged distance rods between the rear axle and the countershaft.

crossed stay pieces, upon which are hung the motor and gearing, the whole construction being hung direct upon the springs. The adjustable radius rod at either side connects the rear axle direct to the angle iron body frame, the turn-buckle enabling the tension of the driving chain to be varied as required. As in the common type of tonneau carriage, the motor is mounted at the front of the body, beneath a suitable bonnet, enabling it to be readily inspected whenever necessary.

Special Constructions.—The gasoline supply tank, arranged beneath the driver's seat, supplies fuel to the motor through a float-feed carburetter, a section of which is shown in an accom-



FIG. 414.—A "Dyke" Light Gasoline Runabout.

panying illustration. Unlike the majority of gasoline vehicles, the gasoline is held under air pressure in the tank, thus enabling the carburetter to be fixed at a higher level, without the use of more complicated devices for raising it as desired. As arranged in these vehicles, the air supply may be injected by the use of an ordinary bicycle pump, an air pressure of 2 pounds, as shown on the gauge dial, being sufficient to raise the liquid gasoline through one foot; and of 4 pounds through two feet. From the fact that it is not necessary to maintain the high pressure used with the fuel tanks of steam carriages, it is evident that the gasoline supply of this vehicle may be much more readily regulated and maintained. The float-feed carburetter is an excellent model of its class, containing, as shown, readily

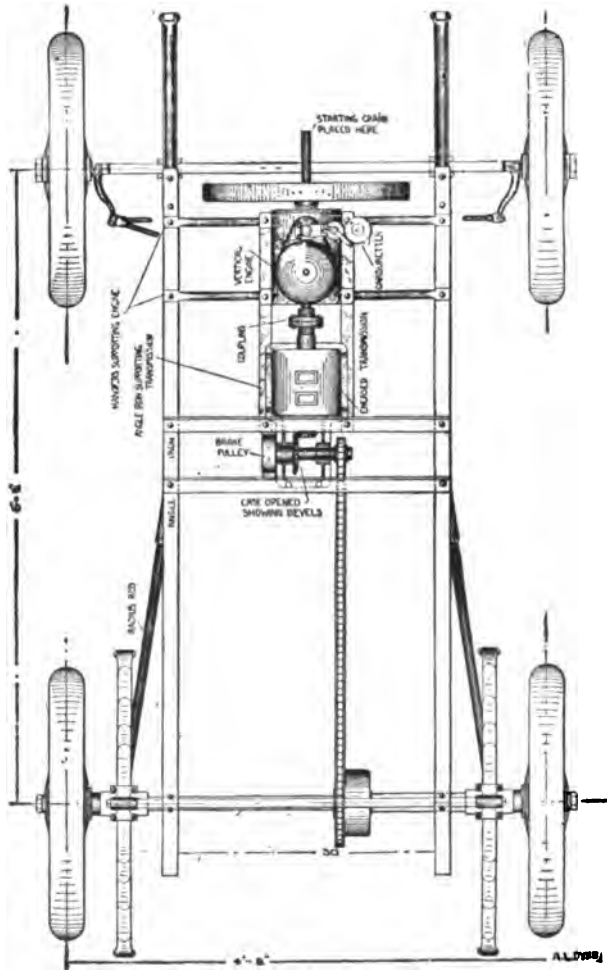

FIG. 415.—Plan diagram of the "Dyke" 6 H. P. Tonneau Carriage, showing position of the working parts, as in Fig. 418.

manipulated arrangements for adjusting the quantity of fuel sprayed into the mixing chamber, and also the amount of air admitted thereto. The fuel supply is regulated by a throttling lever connected to a push button beneath the driver's foot, pressure upon the button regulating the gasoline supply and air inlet to any desired point. A particularly excellent feature not found in many carbureters of this class is the coiled spring attached to the rotatable disc of the throttling device, by which the normal conditions of air and fuel supply may be automatically restored as soon as the pressure of the foot is released. This enables the carburetter to realize a greater degree of automatic action than is possible with most other arrangements. Ignition is by jump-

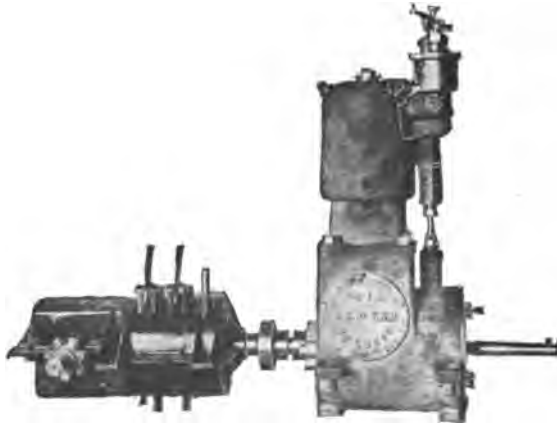

FIG. 416.—The "Dyke" Gasoline Carriage Motor, shown connected to the clutch transmission and change-speed gear.

spark, the primary circuit being periodically broken by the specially constructed vibrator, already described. The vibrator connection, indicated in this diagram, is somewhat different from those used in the De Dion system, since, as here shown, the primary circuit from the battery is made and broken through the vibrator contacts, by virtue of the direct connection between the points, *A* and *B*, which represent the terminals of the primary winding on the induction coil. Unlike the De Dion system, also, both terminals of the secondary winding have visible connections to the motor; one to the insulated body of the plug, the other to the metal of the cylinder. The motor used on this car-

"Dyke" carriages. The body frame, as we have seen, is a rectangular frame entirely of angle iron, and mounted direct upon the springs. By this means the forward and rear axles are entirely independent in their action, and all the compensating action required on rough or uneven roadways is thrown upon the springs, to the entire elimination of the swivel joints and other complications. With the machinery mounted on the angle iron frame and the transmission chain to the rear axle disposed at an angle to the countershaft, the tension of the chain and the fixed distance between the countershaft and the axle is constantly maintained by the action of the radius rods. Although in crossing obstructions the frame tends to go down, the chain cannot become slack, since the radius rods force the rear axle backward

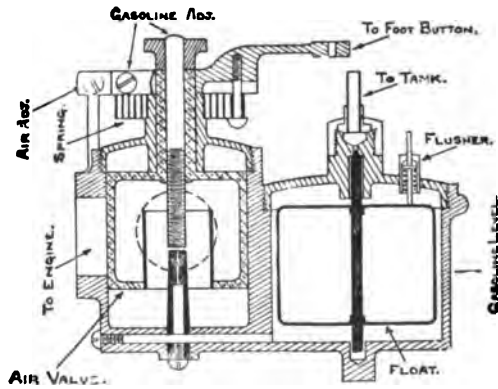

FIG. 418.—Section of the "Dyke" Float Feed Carburetter.

in proportion to the distance of the springs, thus maintaining a steady drive of the motor through any conditions met with on passable roads and entirely preventing all binding. This action of the radius rods is made possible from the fact that the rear springs are attached to the body frame by a flexible joint running in ball bearings, and also because both ends of the radius rods are similarly hinged. The merits of this arrangement seem to have been amply demonstrated, both in points of superior flexibility and in durability. It also operates to economize a suitable percentage of the driving power, which in some other arrangements is needlessly wasted by the inability of the machine to adapt itself to the requirements of varying road surfaces.

CHAPTER THIRTY-SIX.

GENERAL PRINCIPLES OF ELECTRICITY, AS APPLIED TO ELECTRIC VEHICLE CONSTRUCTION.

The Use of Electric Motors on Vehicles.—Vehicles propelled by electric motors, whose energy is derived from secondary batteries, are much preferred by many authorities on account of the combined advantages in point of cleanliness, safety and ease of manipulation. When well constructed and well cared for, they are also less liable to get out of order from ordinary causes. Among their disadvantages, however, may be mentioned the facts that the storage batteries must be periodically recharged from some primary electrical source, which fact greatly reduces their sphere of efficient operation. Since at the present time road vehicles driven by electricity are not the prevailing type, power charging stations are few and far between on the ordinary lines of travel, and it is not possible to make a tour of more than twenty-five miles, at the most, from the base of supplies. It is impossible to counteract this deficiency by carrying an extra set of batteries, since these are so immensely heavy, as usually constructed, as to greatly curtail the speed and carrying power of the vehicle. It is also impracticable to propel a vehicle by a battery of primary cells carried within it, since a battery of sufficient power to propel the vehicle would have little, if any, advantage in point of endurance over secondary cells, and when once exhausted must be entirely replaced. One or two attempts to use a primary battery on a motor vehicle have been recorded, but the great waste and expense involved must continue to render such a construction more of a toy and an experiment than a practical possibility. Some machines, particularly of European manufacture, have attempted to combine the use of electricity with the explosive motor, the latter serving the double duty of driving the carriage and charging the batteries, which may then be used to supply energy for the electric motors. It must be said, however, that such a carriage as this is heavy and complicated to a point vastly in excess of the advantages supposedly gained.

Conditions of Electrical Activity—There are two kinds of electricity according to the usual classification: static electricity and current electricity. As a matter of fact, however, the difference is rather a question of phenomena than of anything more fundamental. The term, static electricity, refers to the phenomena observed in the charging of a condenser, and is attributable to the fact that a body of high electrical potential imparts a portion of its energy to another having a lower potential, just as a heated body gives off a part of its heat to a cold body, equalizing the temperature. The phenomena observed in connection with the electric current differ from the "shock" of the static electricity only in the fact that the current marks a continuous passage of electrical energy from a point of high potential to one of lower potential, showing that the source of E. M. F. is constant, just as a substance in combustion constantly gives off heat. This fact is shown in all types of electrical generators, the galvanic cell operating on the principle that the positive, or high potential, pole constantly transmits its energy along the circuit to the negative, or low potential, pole. The difference in potential, thus observed, indicates a specific physical property differing in the substances composing the two electrodes. The dynamo electrical generator operates according to the laws of magnets, which invariably have the same bi-polar constitution.

The conditions governing the transmission of electrical energy from a point of high potential and the intensity of the current in the circuit are perfectly analogous to the action of a heated body in transmitting a certain portion of its heat to another body, although, after this correspondence has been established, the resemblance is not as readily recognizable.

Electricity Considered as a Force.—Modern science holds, as a fundamental principle, that all force is one, and that its various manifestations are co-relative and transmutable. Thus it is that heat under proper conditions can occasion electrical effects, and that an electric current can produce both heat and light.

Although the various manifestations of natural force are analogous in their operation, and, as we have stated, capable of being transmuted one into the other, it must not be supposed that they are in any practical sense to be identified. Heat is a physical condition, which produces the effect of expansion in the

majority of substances, solid, liquid and gaseous. It is also manifested in the chemical process known as combustion. Electricity is also known by the conditions it produces, causing heat and many of its phenomena, but most familiarly apparent in attractions and repulsions, both molecular and magnetic, and in chemical disturbances and decomposition. It has been defined by a noted physicist as a "powerful physical agent," which is differentiated from other physical conditions solely by its peculiar effects.

Units of Electrical Measurement.—It may be said in a general way that the electric motor has one point of advantage over

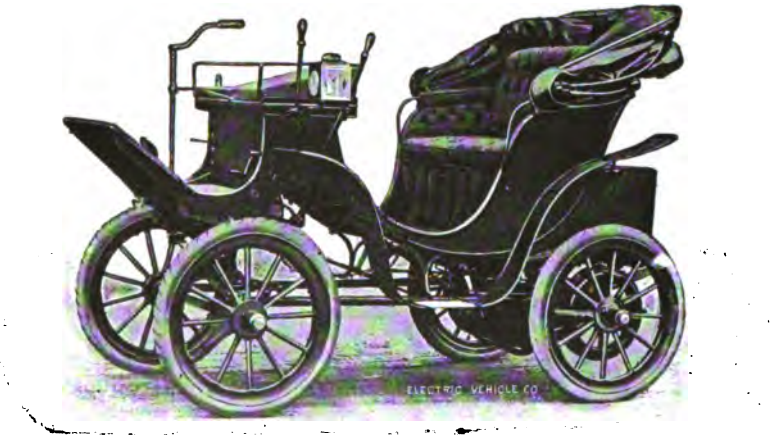

FIG. 430.—"Columbia" Electric Cabriolet; a typical American electric vehicle. This carriage weighs complete about 2,800 pounds; has a radius of forty miles on a complete charge of its battery, and a maximum speed of fourteen miles.

any heat engine, in the fact that it is much more flexible in operation, which is to say more easily regulated, as to speed and power efficiency. It is also possible to obtain a vastly closer approximation to theoretical requirements under the conditions of practical operation, and to estimate much more precisely the power efficiency to be obtained from a given electrical source on any given circuit. This is because the available working energy, in terms of amperes, is in exact proportion to the voltage and resistance of the circuit, as well as to the amount of efficient activity in terms of work accomplished and time consumed. As we have

already seen, the power efficiency of a steam engine is estimated in the first place, in terms of heat and power units; secondly, in terms of foot-pounds or the efficiency of the engine to move so many pounds through such a space in such a length of time; and thirdly, in terms of gauge pressure or estimated temperature. In short, the units of power are all stated in terms of pounds, feet and seconds in estimating the power passed on any given electrical circuit. The units of electrical measurement are stated in terms of length, weight and time, which is to say in terms of centimeters, grams and seconds. This gives the C. G. S. units, as they are called, which are estimated in accordance with the decimal system of measures. The units thus established are, of course, largely arbitrary—just as are all units—but they have been carefully estimated, so that the proportions between current strength, circuit resistance and voltage may be accurately maintained.

The Ohm, the Unit of Resistance.—The first unit of electrical measurement with which we have to deal is the ohm, which is the unit of resistance. This unit measures not only the relative resistance of a circuit composed of a conducting wire of a given length and diameter, as compared with wires of different length and diameter, composed of the same material; but also the specific resistance, or resistivity, which refers to the immense variations in resisting quality found between given wires of the same length and cross-section, made of different materials. The different resistivity of several different metals, as found in circuits, precisely similar in all points of dimensions, is demonstrated in the fact that, while a unit wire of silver shows a conductivity of 100, and one of copper, 99, a wire of iron gives only 16.80.

The value of the ohm, as fixed by the Electrical Congress, at the Columbian Exposition in 1893, is equivalent to the resistance offered to one volt of E. M. F. by a column of mercury 106.3 centimeters in height (about 41.3 inches), and one square millimeter (.00155 square inch) cross-section, determined at the temperature of melting ice (39° Fahrenheit). Mercury was chosen for this test, because on the scale giving a conductivity of 100 to silver, it stands 1.6, while its resistivity is 99.7, as compared with 1.52 for silver; being thus very nearly unity in the first particular, and 100 in the second. One ohm is also equivalent to the resist-

ance to be encountered in one foot of No. 40 B. & S. copper wire, which has a diameter of .003145 inch, or 3.145 mils; or to the resistance encountered in about two miles of the copper wire used in electric trolley lines. In both cases we have approximately the equivalent of the afore-mentioned column of mercury, if the test is made at a temperature of 45° Fahrenheit. In general, the resistance of a circuit varies inversely as the diameter of the wire,

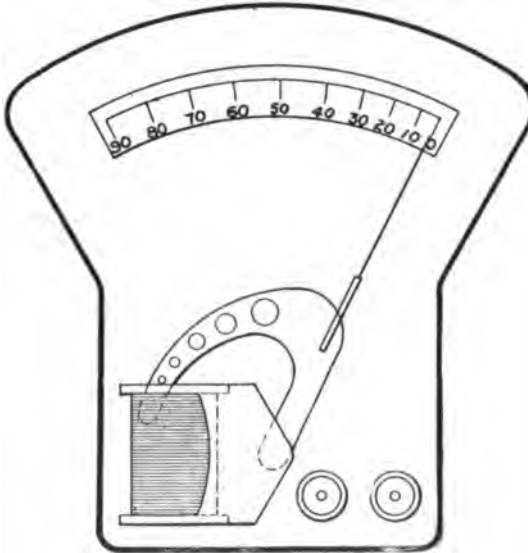

FIG. 421.—Constructional Diagram of one type of Ampere-Meter, or Ammeter. This particular instrument represents the variety known as the solenoid ammeter. It operates as follows: A hollow coil of wire, or solenoid, is connected to the terminals of the circuit, so that the current passes through it. The effect of the passing current is to attract the pivoted iron bar, on one end of which the dial needle is carried. According to the strength of the current passing through the coil the bar is more or less drawn into the eye of the coil. Thus the needle is able to register the amperage on the circuit, according to the determined relation between the conductivity of the wire and the strength of the current passing. The pivoted arm is arranged to be withdrawn from the coil when the amperage of the current falls, either by gravity or a suitably arranged tension spring. Other ammeters are constructed on principles differing from the one shown.

and directly as the length of the wire. In this respect, the waste or absorption of electrical energy required in any circuit to overcome the resistance before accomplishing any actual work, may be compared directly to the corresponding loss of temperature and consequent pressure of steam, when it is conveyed to the engine by tubes of relatively smaller diameter or unusual length,

thus affording a proportionately greater opportunity for such losses as are due to radiation and convection; the loss in efficiency in both cases being due to the fact that a relatively greater proportion of energy is consumed in affecting conditions external to the motor or circuit.

The Ampere, the Unit of Current.—The unit of electrical current is called the ampere, which has been authoritatively fixed as the equivalent of the current strength, which can deposit .00033 grams of metallic copper, by the electro-plating process, in each second of time. In this respect it measures not only the current intensity, or available working energy, but also the rapidity of its exercise. The work above stated might readily be accomplished by a given current in ten seconds, instead of in one, but such a current would not have the value of one ampere, only of 1-10 ampere—since it required ten times as long to accomplish the result.

Another frequently mentioned analogy for the ampere is the so-called miner's inch, which represents the product of an orifice one inch square, through which water is allowed to escape from a given tank or flume, by the height of the column of water in the tank, in inches. The miner's inch, is, therefore, in the first place, a measure of rate or velocity, giving inch-seconds in fact, or the number of cubic inches of water passed in each second of time. Thus, while water flows at the rate of so many miner's inches, the electrical current flows at the rate of so many amperes; the rate per second, in both cases, being directly relative to the original pressure of energy at the source. Thus, it is inaccurate to speak of an ampere per second, since such an expression means simply a current of one ampere; thus also, in speaking of a current of ten amperes, for example, we do not refer to the amount of current passed in ten seconds, but to that passing in one second. There is, however, a unit of electrical measurement, which is called the coulomb, or ampere-second, which is the measure of electrical quantity, being equivalent to the product of the amperage of the current by the number of seconds it has been flowing.

The Volt, the Unit of Pressure.—Having determined the value of the resistance unit and current unit, it is a simple matter

to determine the voltage produced by an electrical source. One volt E. M. F. can produce a current of one ampere on a circuit having a resistance of one ohm. There are several specified equivalents for estimating the exact value of one volt E. M. F., but these usually refer to the determined capacity of some given

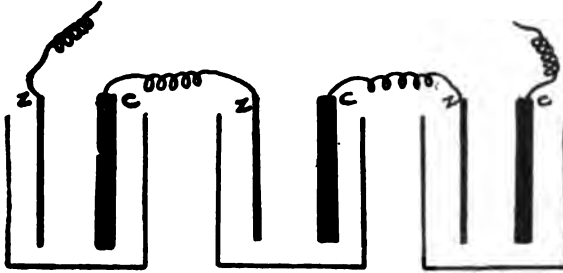

FIG. 422.—Diagram of a *Series* Circuit, showing Three Galvanic Cells in Battery. As shown, the copper, or positive, pole of the first cell is connected to the zinc, or negative pole of the second, and so on; leaving a negative terminal at one end and a positive at the other. Thus the current emerging from each cell passes through all those succeeding in line, the total voltage of the battery being equivalent to the sum of the individual voltages of the several cells. If, on the other hand, several motors, or other electrically affected apparatus, be connected in series, the result is to increase the "back-pressure" (C. E. M. F.) on the same ratio, and hence cut down the operative efficiency of each.

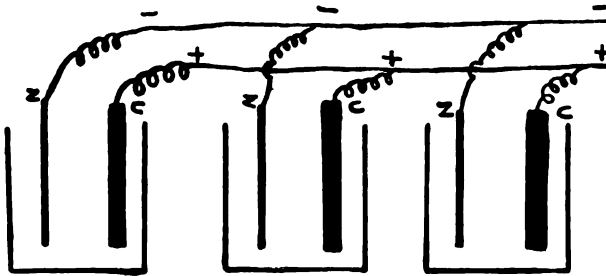

FIG. 423.—Diagram of a *Multiple*, or *Parallel*, Circuit, showing Three Galvanic Cells in Battery. In this system of forming the battery there are two main lead wires, one connected to the positive poles of all the cells, the other to the negative poles. Unlike the *series* system shown above, the effect is that the total voltage of the battery is equivalent to the voltage of one of the cells only, the pressure seemingly being cut down by this wiring. If, on the other hand, a number of motors, or other electrically affected apparatus, be connected in multiple, the "back-pressure" (C. E. M. F.) is similarly decreased, enabling each one to give its highest operative efficiency.

type of galvanic cell. It is sufficient to say, however, for ordinary purposes, the majority of commercial chemical cells are constructed to yield approximately one volt. The ordinary Daniell cell used in telegraphy has a capacity of 1.08 volt, and the common type of Leclanché cell gives about 1.50.

Ohm's Law of Electrical Circuit —The value of the volt, as just given, which is to say, the amount of E. M. F. able to produce a current of one ampere through the resistance of one ohm, gives us a very good general statement of the fundamental principle of electrical science, which is popularly known as Ohm's Law. This is a law of proportions between the three factors in the production of electrical energy, by which any one of them, as well as the total power efficiency of the circuit, may be readily determined.



FIG. 424.—“Columbia” Electric Phaeton. This is one of the most popular and serviceable styles of American electric vehicle. It weighs about 2,800 pounds; has a radius of about forty miles per charge of battery, and a maximum speed of twelve miles per hour.

Ohm's Law may be specifically stated under six heads, as follows:

- (1) The current is in direct proportion to the electromotive force, and in inverse proportion to the resistance.
- (2) The current is equal to the electromotive force, divided by the resistance.
- (3) The resistance varies directly with the electromotive force, and inversely with the current; hence,

(4) The resistance is equal to the electromotive force, divided by the current.

(5) The electromotive force varies directly with the current and with the resistance; hence,

(6) The electromotive force is equal to the current multiplied by the resistance.

As may be readily understood, however, all these various rules are merely so many different ways of stating the proposition involved in the first, which is, in fact, simply equivalent to that involved in the definition of the ohm already given.

The Watt, the Unit of Activity.—Having stated the law of proportions between the various component elements of a live circuit, we may readily see that the unit of active work performed by the current must stand in some determinable proportion to the other elements. Accordingly, we find that the unit of electrical activity, which is known as the watt, and which represents the rate of energy of one ampere of current under a pressure of one volt, is equivalent to the product of the voltage by the amperage.

Other equivalents of the watt make it equal to the product of the resistance by the square of the current, or the quotient of the square of the voltage by the resistance. Thus, a current of ten amperes at a pressure of 2,000 volts will develop 20,000 watts, as will also another given current of 400 amperes at fifty volts.

The operative capacity of an electrical motor is usually stated in terms of watts, or kilowatts (1,000 watts), which may be reduced to horse-power equivalents by dividing by 746, which figure indicates the number of watts to an electrical horse-power.

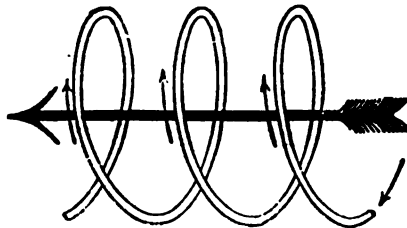

FIG. 425.—Diagram illustrating the directions of the current in the field windings and the induced current, as found in magnets, solenoids and dynamo operation.

CHAPTER THIRTY-SEVEN.

THE CONSTRUCTION OF THE DYNAMO ELECTRICAL GENERATOR AND THE ELECTRICAL MOTOR.

Electrical Induction.—Electrical induction, as manifested in its simplest form, has been repeatedly demonstrated by two contiguous circuits of wire, the one containing an electric battery or other source of current, together with a switch for alternately opening and closing the circuit as desired; the other circuit of wire containing no battery or other source of current, but having its terminals connected to a galvanometer. If, now, we close the first circuit, allowing the current to flow from the electrical source, we will observe, as indicated by the galvanometer, that a current of somewhat less strength is flowing in the other circuit, in an opposite direction. This induced current, however, is only momentary, continuing only long enough to allow its strength and direction to be recorded. On opening the circuit, including the battery, thus cutting off the current, we again notice, as recorded by the galvanometer, that a current, weaker than the first one observed, is flowing in the second circuit in the same direction as that which has just been cut off in the first. This current is also momentary.

In regard to this phenomenon, several principles may be stated:

(1) Increasing the strength of the current in circuit 1 increases the strength of the momentary current in circuit 2.

(2) Decreasing or cutting off the current in circuit 1 decreases the strength of the current in circuit 2, also causing it to flow in the same direction as the current in circuit 1.

(3) If we move the current-carrying wire of circuit 1 nearer to the wire of circuit 2, we will find that a strong current is induced in circuit 2, which moves in a direction opposite to that in circuit 1. If we move the wire in circuit 1 further from the wire in circuit 2, we find that a weaker current is induced in circuit 2, moving in the same direction as that in circuit 1.

(4) If the wire used in circuit 1 is of low resistance and that used in circuit 2 is of high resistance, the current induced in cir-

circuit 2 will show a greater electromotive force than that flowing in circuit 1. Conversely, if the wire used in circuit 1 be of higher resistance than that used in circuit 2, the current induced in circuit 2 will show a lower electromotive force than that flowing in circuit 1.

The Production of Magnets.—The most familiar operation of current induction is seen in the production of an electro-magnet, which consists of a core of soft iron wound about with a certain length of insulated wire, preferably copper, on account of its high conductivity. As soon as a current is sent through the wire

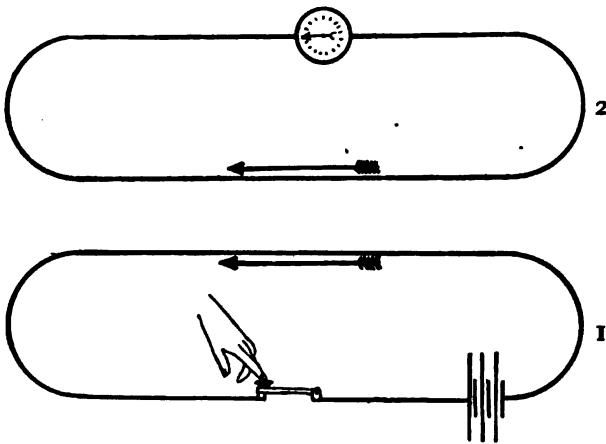

FIG. 426.—Diagram Illustrating the Action of Voltaic Induction Between Two Circuits: the one including a source of electrical energy and a switch; the other including a galvanometer, but having no cell or other electrical source. The direction of the battery current in circuit 1 is indicated by the arrow; the arrow in circuit 2 showing the direction of the induced current.

coiled about the iron core, its effects are seen in the fact that the core becomes magnetic, attracting iron and steel bodies, and in general exerting an observable effect upon any polarized conductor, such as a solenoid. As soon as the current in the insulated winding is cut off, the iron core loses its magnetic properties. If, however, a core of hardened steel be similarly wound with insulated wire, and a strong current be sent through it, the result will be that the steel will become a permanent magnet,

which is able to exert the characteristic magnetic effects for a practically indefinite period.

A bar of iron or steel thus temporarily or permanently magnetized invariably shows the phenomenon of polarity, manifested in the first place by the ability to attract the unlike poles and repel the like poles of another magnet, the poles being always determined as positive or negative by the points of the inlet or exit of the current, as in the case of solenoids. The magnet can also induce a momentary current in a closed circuit of wire in exactly the same fashion just described in connection with the ordinary action of current induction. These simple experiments demonstrate the fact that between the poles of any magnet there is a continual operation of force, the lines and activity of which may be shown by scattering iron filings on and between the two extremities. These iron filings, if allowed to adjust themselves, in obedience to the magnetic force exerted upon them, will be found to be thickest at the points nearest the extremities of the poles, and lightest at the points furthest from the extremities, in the latter positions describing arcs of circles, thus showing the strength and direction of the force acting upon them. Further, the intensity of the magnetic force is shown to be greatest when the two poles are connected by a piece of iron or steel, known as an armature, this being efficient in prolonging the magnetic activity of a permanent magnet, and preventing the dissipation of the magnetic force through a much longer period.

Electrical Dynamos and Motors.—The machines for converting mechanical movement into electrical current, and for converting electrical current into mechanical movement, in other words, the dynamo generator and the electric motor, respectively, are the same so far as the general features of their construction are concerned. In operation, however, the motor is the exact reverse of the dynamo. As just stated, the theory of electrical generation by mechanical means is that the lines of force of a magnet should be cut through, so that their strength and direction at any point or at any time should be made to vary constantly. In addition to this, it is necessary that there should be some means of collecting the current, resulting from the continual disturbance of the magnetic field, and supplying it to a circuit.

The Operative Principles of a Dynamo.—In order to review the principles involved in both the generation and mechanical utilization of the electrical current, it will be necessary briefly to enter into somewhat rudimentary principles. In an accompanying cut may be seen a diagram representing the simplest conceivable dynamo electric generator. As may be seen, the spindle, *A*, rotates between the two poles, *N* and *S*, of the magnet. Upon this spindle, *A*, is carried a loop of wire, the two terminals of which are connected to the two drums carried on the forward end of *A*. The metal of these drums, as indicated in the cut, is insulated from *A*, so that all the electric current generated by the machine may be taken up by the brushes, *B*¹, *B*². It is obvious that, when the spindle, *A*, is rotated in the direction of the arrow at the top of the cut, the double loop, *CC*, will cut through the lines of force, indicated by the dotted lines between *N* and *S*. Since, therefore, these lines of force have a more direct path between the two poles, when the loop, *CC*, is in a horizontal position than when it is in a vertical position, as shown in the cut, it follows that the momentary current induced in the circuit formed by brush, *B*¹, loop *C*, brush, *B*², and the outside circuit wire, *E*, connecting the two brushes, will constantly vary in strength, and also in direction of movement, as the two parts of the loop are moved towards and from the poles, *N* and *S*. Since the direction of the current must constantly fluctuate with the movement of the armature loops, *CC*, it follows that the current delivered to the outside circuit, *E*, through the two brushes, will be an alternating current, which is to say, one flowing first in one direction and then in another, the potential varying with the direction of flow. In order to make the current flow constantly in one direction, it is necessary to use a collector or commutator, the construction of which will be explained in place. Without this all dynamo currents would be alternating.

The armature of a practical dynamo or motor differs from the simple loop shown in the figure just mentioned, principally in the fact that a large number of such loops are mounted on a single rotating spindle, so that the magnetic lines of force are cut through a correspondingly larger number of times in a given period, with the result that the poles are shifted at a much higher frequency, and the alternations of the produced current are much more rapid.

The Essential Parts of Dynamos and Motors.—The essential parts of a dynamo generator and also of an electric motor are:

- (1) The field magnets constructed like ordinary electro-magnets, and having two or any even number of opposed poles with their windings connected in series.
- (2) The armature rotating between the fields, so as to cut the lines of magnetic force.
- (3) The pole pieces, which are the exposed ends of the magnet cores.
- (4) The commutator or collector.

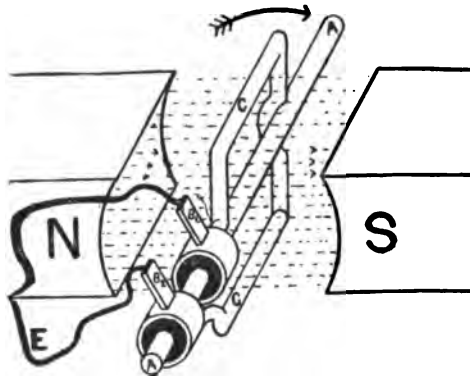

FIG. 427.—Diagram of a Dynamo Electrical Generator, arranged for producing an alternating current, showing the constructional and operative features. Here N and S are the positive and negative poles of the field magnets, between which the lines of force are shown by the dotted lines. A is the armature spindle; B¹ and B², the brushes bearing on the ring drums; C, the coil, or winding, of the armature; E, the outside circuit to which the current is supplied.

- (5) The brushes which rest upon the cylindrical surfaces of the commutator, and as the terminals of the outside circuit, take up and deliver the current generated in the coils of the armature.

The Varieties of Dynamo-Generators.—There are a number of species of dynamo, discriminated according to the use for which they are intended, the arrangement of the armatures, the winding of the field magnets, and the kind of current they are intended to produce. For general purposes, however, we may discriminate three familiar forms of dynamo, according to the system adopted in the winding of the field magnets; these are:

- (1) Series-wound dynamos, in which the two poles of the mag-

net are wound with a few turns of a heavy low resistance wire, one terminal of which is connected to one of the brushes, moving thence entirely around both pole cores, thence to the outside line and back through the other brush.

(2) Shunt-wound dynamos are wound in the same fashion as the series-wound, with the exception that the pole cores are wound with a large number of turns of high resistance wire, the field windings, however, forming a shunt-circuit from the main outside circuit, which has its terminals at the two brushes bearing on the armature. The terminals of the field magnets are also connected to the brushes.

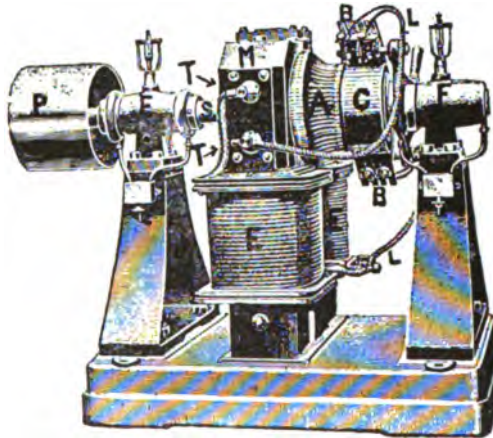

FIG. 428.—A Typical Dynamo-Electrical Generator, with parts lettered. A, the armature; B, B, the brushes; C, the commutator; E, E, the windings of the field magnets; M, the pole piece of the salient field magnet; F, F, bearings of the armature spindle; L, L, the lead wires; P, the pulley; T, T, terminal connections of the outside circuit.

(3) Compound-wound dynamos combine the features of both the series and shunt-wound machines, having the field magnets double-wound with (a) a few turns of heavy low resistance insulated wire connected to circuit as in the series-wound dynamos, and (b) a second winding arranged precisely as in a shunt-wound dynamo.

Shunted Field Windings, Their Use.—The object of using a shunted circuit for the windings of field magnets is that the machine may more readily excite its own fields at starting, and that

the current may be produced before the rotating armature has fully taken up its speed. Some dynamos have their fields excited by a separate source of electrical energy, in which case the magnet windings are not connected to the brushes' ends, on the armature, but direct to the terminals of the outside source of electrical energy. As a usual thing, however, it is unnecessary to use a separate source of current, for exciting the magnetic fields, since there is a sufficient amount of residual magnetism, acting between the poles of the magnets, to start the generation of electrical energy, as soon as the armature begins to rotate.

Residual Magnetism and Current Generation—This residual magnetism, which is a familiar property of an electro-magnet, that has once been magnetized, of course, has very weak lines of force at the beginning of the rotation, but these weak lines, being cut through by the coils of the armature, are able to produce a small amount of E. M. F., which sends a minute current through the windings of the field magnets, in consequence of which both the E. M. F. and the field currents are constantly increased until the rotation of the armature has reached its maximum speed. At this point, also, the output of the electrical energy has attained its highest point.

Construction of a Practical Armature.—The armature of a dynamo or motor consists of a drum or ring forming a core and support, upon which a number of coils of insulated copper wire are wound in the same general fashion as has been shown in connection with the ideal simple dynamo already mentioned. The drum or ring forming the supporting core is attached to the rotating spindle by a spider or key. The latter attachment is universally used with drum armatures. The most usual method of constructing armature cores for dynamos is to build them up by placing together, face to face, a number of thin discs of soft sheet iron, which are insulated one from the other by suitable varnish or enamel. The circumference of each of these discs is toothed or serrated, so that when a number of them are placed together the cylindrical armature body has a corresponding number of deep grooves running in its length. Into these grooves the insulated wire of the winding is inserted. The greater the number of the teeth in the circumference of the arma-

ture drum, the smaller the danger involved in the production of eddy currents, which are a troublesome source of overheating and other derangements of the machine. It is essential that the cores of the rotating armature should be composed of the softest iron in order that the greatest magnetic permeability may be obtained, since the body of the armature forms an integral part of the circulation.

The Commutator and Its Use.—The commutator of the dynamo or motor is one of the most essential elements in the generation and use of the current: Its function is to collect the current produced by the cutting of the lines of magnetic force, so as to cause them all to concur to a desired result, transforming what would naturally be an alternating current into a direct current. As usually constructed, the commutator consists of a number of L-shaped metal pieces, which are so formed that when one arm of each piece is connected to the insulating disc at the end of the armature drum, the other arm will constitute one segment of the cylinder arranged around the armature spindle. In general, the commutator is formed of alternating sections of conducting and non-conducting material, running lengthwise to the axis, upon which it turns. Each segment, as we have already seen, constitutes the point of connection between two sections of the armature winding; it is thus possible to collect the currents induced in the winding at the desired point, for although the effect of the magnetic induction upon the windings of the armature naturally tend to produce an alternating current, as already suggested, there are, as will be subsequently explained, certain points in the rotation of the armature at which the induced currents invariably move in one direction, owing to the permanence of the magnetic conditions at those points. These points are known as the neutral points, or points of commutation, and in order that the direction of the current sent over the outside circuit may be perfectly constant, the brushes which form the terminals of that circuit are here placed upon the commutator. In other words, the brushes are so arranged that they will bear upon the conducting segment of the commutator at exactly the neutral point in the rotation of the armature. These neutral lines are situated at either extremity of its determined diameter of commutation, which diameter is theoretically at right angles to the

direction of the magnetic lines of force, as estimated for a two-pole magnet, and would be in that position practically but for the magnetic lag, which slightly varies the angle. The number of segmental bars on the cylindrical end of the commutator is naturally dependent upon the scheme of winding adopted on the armature, and the number of sections into which it is grouped. In general, an increase in the number of segmental bars diminishes the tendency to spark and lessens the fluctuations of the



FIG. 438a.—“Columbia” Electric Runabout. This carriage, weighing about 1,900 pounds, has a traveling radius of about forty miles per full charge of battery, and a maximum speed of thirteen miles per hour.

current. The increase in the number of bars, however, has fixed limits for several reasons. In the first place, principally in large machines, a great increase in the number of bars has a tendency to increase the voltage of the dynamo beyond the safe limit. In smaller dynamos, trouble speedily arises from the fact that each bar becomes so thin that a brush of proper thickness to collect the current would lap or bridge over more than two of them at once.

CHAPTER THIRTY-EIGHT.

THE OPERATION OF ELECTRICAL GENERATORS AND MOTORS.

Conditions of Dynamo Operation.—The dynamo electrical generator is a very sensitive and delicately organized machine, demanding for its efficient operation perfect adjustment of its various parts and a constant watchfulness for any symptoms of dynamo disease, overheating or sparking, or any of the results usually following imperfect adjustment or careless handling. These conditions, however, need not be enlarged upon here, since we are concerned only with the essentials of construction alike to the dynamos and motors, and with the general principles upon which the generation and use of the electrical current depend.

As already stated, the operation of a self-excited dynamo is largely indicative of the principles upon which it operates: The cutting of the lines of the residual magnetism between the cores of the field magnets, the production of induced currents in the coils of the armature, and their transmission through the circuit of the field magnet windings, where they are efficient in increasing the magnetism of the cores, also the E. M. F. output of the machine, as the rotation of the armature approaches the maximum speed.

The Polarization of the Armature.—The usual rule applying to the efficient operation of a dynamo is that the E. M. F. produced is in proportion to the number of turns of wire wound about the armature, and within definite limits also to the speed of its rotation. The result of the rotation of the dynamo armature is to produce a number of reactions between its windings and the magnetic field, with the result that the armature itself becomes a magnet, being constantly polarized at certain definite points in its path of rotation. According to the accepted rule of magnetic induction, the tendency is to produce poles in the armature at right angles to the lines of force, but since the neutral points, theoretically situated on the same diameter, are points of contact between the brushes and the commutator, where the cur-

rent leaves and re-enters the winding of the armature, it will be found that the armature is really transformed into two separate adjacent magnets, having two north and two south poles, on either side of the diameter of commutation. These double poles, practically operating as a single pole, at the two extremities of the given diameter, act to produce the great distortion of the lines of magnetic force, which follow the rotation of the armature. As shown in an accompanying diagram, these lines of force are twisted into an oblique direction. This result is largely due to the fact that the polarity of the armature is not symmetrical with that of the field magnets. Were the brushes placed at any other point than the extremities of the diameter of commu-

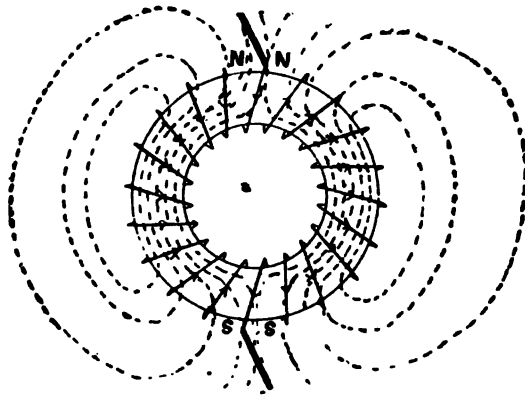

FIG. 429.—Diagram of the Polarization of a Rotating Dynamo Armature of the Ring Type, showing directions of the lines of force and of the induced current.

tation, the result would be short-circuiting of the armature coil. This distortion of the magnetic field, which is an important agent in the production of the current, must be regarded as the resultant of the two induced polarities of the armature, one of which is due to induction from the field; the other to induction from its own windings. It marks the fact that, in the process of shifting the neutral points as the armature rotates, the induced polarities are continued, with decreasing effect to be sure, hence continuing to exert an attractive or repelling reaction upon the field magnets.

As shown in an accompanying figure showing the polarization of the rotating armature, it will be seen that the current pro-

duced in the armature windings are moving in two different directions between the contacts of the brushes. Entering at the north poles of the armature, their direction is through the windings, down either side to their exit at the south poles. These two oppositely moving currents, flowing between the north and south poles of the armature, which is to say between the negative and positive brushes, respectively, act upon the body of the armature after the manner of a current flowing in the windings of an electro-magnet, or through the helical portion of a solenoid. The result is that an induced current is set up in the armature itself, which, according to the rule above-mentioned, moves at right angles to the direction of the inducing current in the windings.

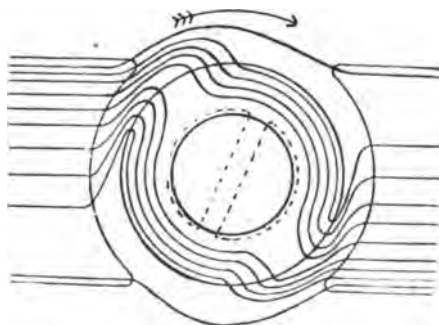

FIG. 430.—Diagram of the Distortion of the Lines of Magnetic Force as they pass through the Body of a Rotating Dynamo Armature.

Principles of Electrical Motor Operation.—The foregoing discussion of the dynamo electrical generator is included in this work, in order to prepare the reader for a better understanding of the electrical motor, for, as already stated, the electrical motor is the exact opposite of the dynamo in all matters touching its practical operation. This means that a typical dynamo may be run as a motor, with no other alterations than changing the position of the brushes to the negative lead.

The respective action of a motor and a dynamo may be understood from an accompanying diagram. It shows a dynamo and a motor coupled together, so that the current generated in the former is driving the latter. As will be seen, both the dynamo and the motor are rotating right-handedly, thus generating an

electromotive force, tending upward from the lower brush to the higher, each upper brush, in this case, being the positive terminal of the circuit. The cut also shows that the brushes of the dynamo are advanced in the direction of the rotation, while the brushes of the motor are advanced backward in the opposite direction. The result of this variation in the arrangement of the brushes is, as is also indicated, the electromotive force in the dynamo, from which current is given forth, is in the same direction as the current, both moving from the lower to the upper brush, up either side of the armature. In the motor, however, where work is being done, and energy is leaving the circuit, the electromotive force is in a direction opposite to the current; the former moving from the lower to the upper brush, the latter from the

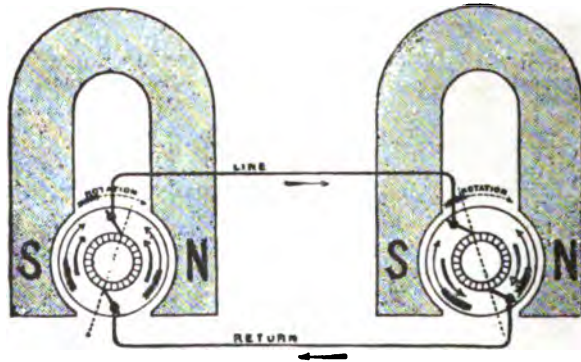

FIG. 481.—Diagram Showing the Operative Conditions of a Dynamo Generator and Electrical Motor. The machine on the left is the dynamo, that on the right the motor.

higher to the lower brush, as indicated in the cut by the arrows. This brings us to the most essential practical difference between the theories on which the operation of dynamos and motors depend.

Comparison of Dynamos and Motors.—As already explained in connection with the dynamo, the rotation of the armature cutting the lines of residual magnetism constantly tend to increase the electromotive force of the current conducted to the coils and the field magnets, with the result that the E. M. F. of the current generated is constantly augmented, as the induced magnetic lines increase in number of strength until the maximum is attained.

With the motor, however, the current fed to the circuit is imparted partly to the windings of the armature and partly to the windings of the pole magnets, with the result that, both assuming polarity, the magnetic action tends constantly to attract the opposite poles of the armature, thus imparting a rotative movement. Thus the magnetic drag, which in the dynamo acts in the direction opposing rotation, and is, in fact, the reaction against the driving force, is in the case of the motor the real driving force, which propels the revolving armature, representing the pulling influence which the magnetic field exerts upon the armature

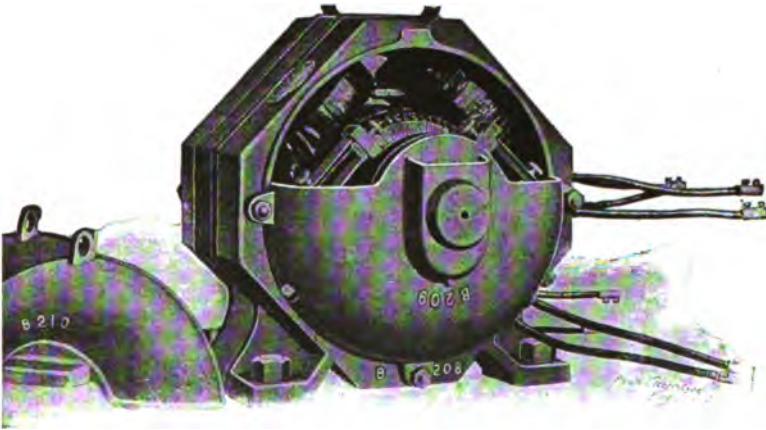

FIG. 432.—The "Lundell" Octagon Motor, with case open, showing parts.

wires, through which the line current is flowing, and also upon the protruding metal portions of the armature core.

This operation is in accordance with the law relating to a current-carrying wire, situated in a magnetic field, in accordance with which it experiences a side-thrust, as it is called, which tends to move it forcibly in a direction parallel to itself, across the direction of the lines of magnetic force. This fact is well illustrated in Fig. 425, on page 545, in which the large arrow is represented as moving through the coil of wire, carrying current. The direction of the current in the wire is indicated by the small arrows, and the side-thrust, or magnetic push, by the large arrow,

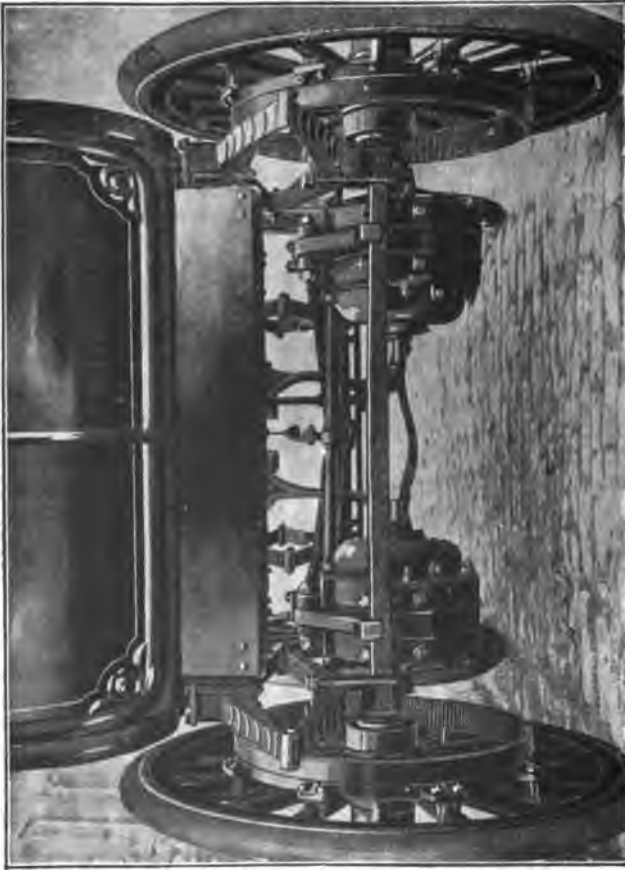

FIG. 488.—The Manner of Attaching Two-Carriage Motors, one for each wheel, with single reduction of speed. The motors are of the well-known "Lundell" octagon type.

Action of the Field Magnets of a Motor.—The second point to be considered in the practical operation of an electrical motor is that, while the magnetic action of the field tends to produce a rotation in the armature, the same rotation, necessitating that the armature windings cut through the magnetic lines of force, tends to the production of a counter electromotive force (C. E. M. F.), which, as previously mentioned, moves in a direction contrary to the direction of the current. As may be readily understood, the more rapidly the armature rotates, the greater will be this C. E. M. F., on account of the fact that a stronger field is necessary for the increase of speed, and, consequently,

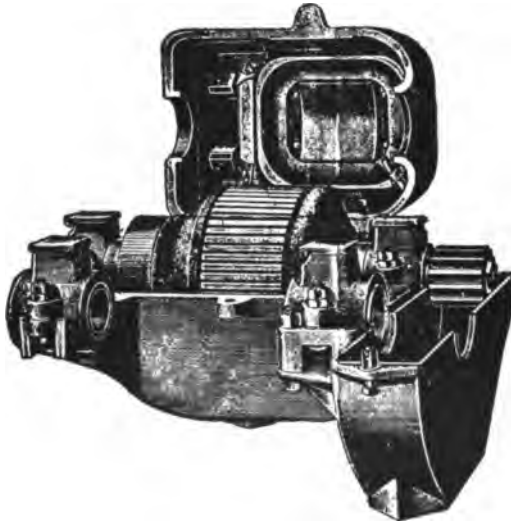

FIG. 484.—A Heavy Vehicle or Street-Car Motor, with single reduction, showing working parts in position.

that a greater number of magnetic lines are produced, which the armature must cut through.

Two facts, however, follow from this condition :

(1) As the armature revolves more rapidly, there is a diminished resistance to its motion, and on account of the increase of C. E. M. F. less energy is absorbed.

(2) When the motor is working under load, the armature necessarily revolves more slowly, with a consequent fall in the generation of C. E. M. F., and a greater absorption of energy.

The Speed and Torque of a Motor.—As may be understood from what has just been said, the increase of speed marks an increase of power in an electrical motor, just as in a steam or gasoline engine. There is, however, another consideration relating to the power of a motor, and that is the drag or rotative energy brought to bear upon the circumference of the pulley or spur attached to the end of the armature shaft. This electro-dynamic force, which tends to produce rotation of the shaft, is known as the torque, which is to say, the twisting power of the motor.

In estimating the efficient power of a motor, we have, therefore, to consider three elements :

(1) The power measured in pounds weight, which originally causes the rotation of the armature spindle, and which may be readily determined by experimenting with pulleys of various

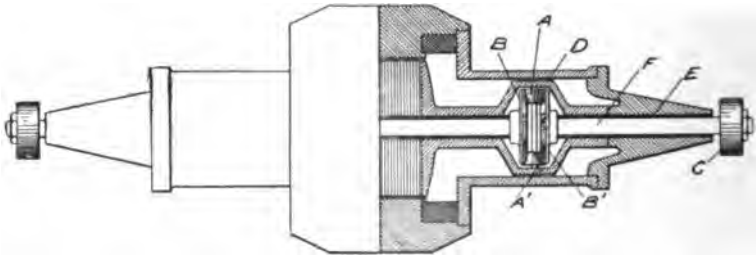

FIG. 435.—Part Sectional Diagram of a Single Motor, arranged for driving both wheels through differential gear. A and A' are the pinions of the differential gear; B, the bevel gear of the left-hand road wheel; D, bevel gear on right-hand road wheel; C, spur pinions driving internal gear on road wheels; E, sleeve on rotating shafts, F, of pinions, C and C.

sizes, showing the power to raise various weights, or by a form of Prony brake, somewhat of the same description as is used for determining the efficient power of a steam or gasoline engine, as has been already described.

(2) A second element entering into the determination of the efficient power of a motor is the diameter of the pulley.

(3) The number of revolutions per minute attained.

Illustration of Torque.—The operation of the torque of a motor may be illustrated by an accompanying diagram, in which, as shown, a rope wound about the axis of a pulley, *P*, and having a weight, *W*, attached to it, is able to cause the rotation of a

pulley through the force of gravity exerted on the weight, W . Now the efficiency may be determined by two considerations: (1) The number of pounds in the weight, W , and the diameter of the pulley, P . If, for example, the weight is fifty pounds, and the pulley is of the same diameter as the shaft around which the rope is wound, the weight, W , will exactly balance a weight equal to itself; if the pulley is twice the diameter of the shaft, the weight, W , will be balanced by a weight of twenty-five pounds, and so on indefinitely; the amount of weight necessary to balance weight, W , being always in inverse proportion to the difference in diameter between the shaft on which it is coiled and the pulley, to which is attached the rope carrying the counter-weight. This is in accordance with the law of levers, that the power exerted on the long arm of a lever can raise a weight as much greater than itself, as the long arm is longer than the short arm, to which the

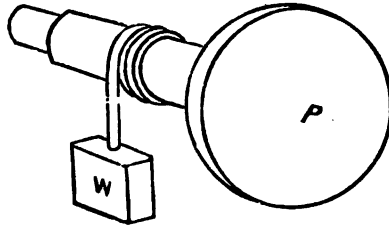

FIG. 496.—Diagram Illustrating the Theory of Torque.

latter weight is attached. Consequently, if the torque at the shaft of a motor armature is equivalent to 100 pounds for that diameter, it can exert a power of only fifty pounds with a pulley of twice the diameter of the spindle, and of only twenty-five pounds with a pulley of four times the diameter of the spindle.

This principle may be stated in another manner: that the pulley is capable of raising a weight which is in inverse ratio to the power exerted on the spindle of the armature, as the diameter of the pulley is greater than that of the spindle, because the work required of it is to raise its weight through a vertical distance equal to its own circumference. If, then, a pulley of 1 foot circumference can raise a weight of 1 pound to a vertical distance of 1 foot, a pulley of 4 feet circumference can raise only $\frac{1}{4}$ of a pound through a vertical distance of 4 feet.

On Electric Vehicle Motors.—In the practical use of electrical energy for the production of power, electric lighting and other uses, the current is sometimes fed direct to the circuit from the dynamo, and in other cases the dynamo is used in connection with storage batteries, whose office is to combine the functions of equalizing the load, as it is called, when the dynamo is in operation, or supplying such current as may be required, when it is not desirable to drive the dynamo. In the motors used on electric vehicles, the current is supplied by storage batteries, which must, of course, be periodically recharged, in order that the vehicle may be operated at all. One

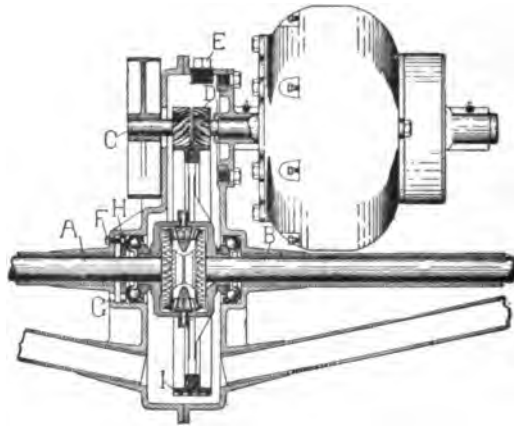

FIG. 437.—Diagram of Single Motor Attached to Rear Axle Through Single Reducing Gears. A is the left-hand section of the divided rear axle; B, the right-hand section of the rear axle; C, the brake drum; D, the spiral pinion on the motor shaft driving the worm gear, I, on the differential; H, ball race on the axle bearing.

or two manufacturers of electric vehicles, however, have adopted the plan of mounting a dynamo on the vehicle to be continually operated by a gasoline engine. A storage battery is also included for the purpose of equalizing the load by absorbing the current not required for propelling the motor, when the vehicle is coasting down hill, or when it is brought to a standstill with the gasoline engine still in operation. It can then supply the extra current required in ascending particularly steep grades or coming through unusually heavy roads.

Although it may seem that a combination of the two types of motor, in one vehicle, one of them having no connection what-

ever with the driving gear, is something of a waste of energy, it may be said that the advantage gained is two-fold: first, the great weight of the storage batteries, required to operate a vehicle of given size and weight, is very largely saved; the combined weight of the gasoline engine, dynamo and auxiliary storage battery, representing a far higher percentage of power with less inconvenience, than a similar weight with storage batteries

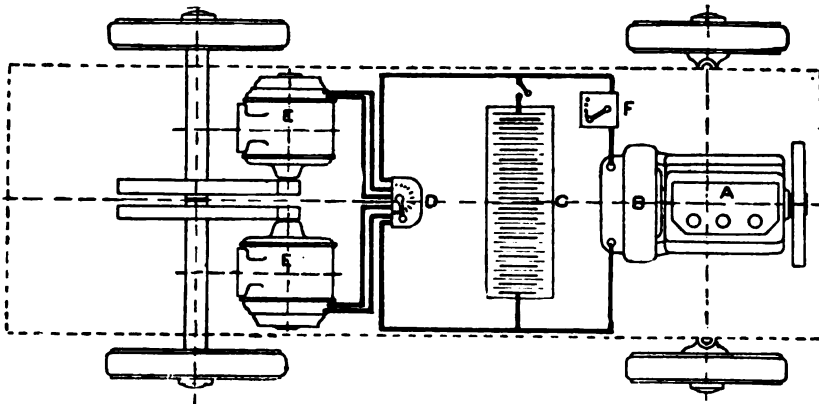

FIG. 428.—The Fischer Electric Omnibus, driven by dynamo direct. A is the gasoline engine, driving the dynamo, B; C, the storage battery; D, the switch; E, E, motors; F, rheostat.

alone. Secondly, the electric motor is at once the most economical means of power transmission, and also most readily regulated, as regards speed and power output; thus saving the complicated, expensive and uncertain methods of changing speed and power ratios, employed on the average run of gasoline vehicles. In other words, the electrical system of transmission is superior in point of flexibility of control.

CHAPTER THIRTY-NINE.

METHODS OF CIRCUIT-CHANGING IN ELECTRICAL MOTOR VEHICLES, AND THEIR OPERATION.

Varying the Speed and Power Output of a Motor.—The methods employed to vary the speed and power output of an electric vehicle motor consist briefly in such variation of the electric circuits as will modify the pressure of the batteries on the one hand and the operative efficiency of the motors on the other. This is a very simple matter and may be expressed in a few words. As is well known, there are two general methods of connecting up both electric batteries of any description and electric motors. They are the series-wiring and the multiple-wiring, or parallel-wiring. In series-wiring, various cells of a galvanic battery, or the several units of a battery of dynamos, are connected in line. At one terminal of each is the negative pole, at the other the positive—each unit in combination having its negative pole connected to the positive pole of the one next following. In the parallel method of wiring the various units are each separately connected at their positive and negative poles to two lead wires, one of which is the positive pole of the battery, the other the negative.

Effects Obtained by Varying the Circuits.—Electric motors, lights and other electrically effected devices are similarly connected in circuits, either in series or parallel. Now, in the matter of circuit arrangements on this plan, one general principle may be laid down, which is that a connection of a number of electrical generators in series involves an increase in the power pressure of the battery, which is equal to the sum of the individual voltages. Connecting a number of generating units in parallel or multiple has the effect of producing a pressure only equal to the voltage of one of the units. Thus, if four generators of 10 volts each be connected in series, the pressure is equal to 40 volts. If, however, they be connected in parallel or multiple, the pressure is equivalent to but 10 volts, the effect in the latter case being the same as if but one unit were in circuit, so far as

the voltage is concerned. On the other hand, where four motors are connected in series the efficient pressure of the circuit is reduced to very nearly $\frac{1}{4}$ for each motor, the C. E. M. F., generated by their operation, serving to cut down the average of efficiency; but when four motors are connected in parallel, which is to say, bridged between the limbs of the circuit, the greatest available pressure of the battery is able to act upon each one of them.



FIG. 439.—Square-front Brougham, Riker type, for city and general family service. The weight of this carriage is 4,000 pounds; travel radius per full charge of battery, thirty-five miles; maximum speed, twelve miles per hour.

Arrangement of the Batteries and Motor Parts.—In an electric vehicle the storage batteries are arranged so as to form a number of units, the circuit wiring being so arranged that by the use of a form of switch known as a controller the connections may be varied from series to multiple, or the reverse, as desired. The same arrangement for varying the circuit connections is used for the field windings, and, with some manufacturers, for the brush connections also. In the accompanying first diagram of the connections of an electric vehicle this fact is indicated. The dotted lines on each figure indicate the cir-

uits that are cut out, or open, and the full lines those that are active, or closed. In the figure showing the first speed, we have the two units of the battery, *B*, connected in multiple, which means that the voltage is reduced to the lowest point. The wire, *C*, connected to the bridge between the positive poles of the battery, leads the current to the field windings, *H* and *J*, which, in this figure, are connected in series-multiple, which

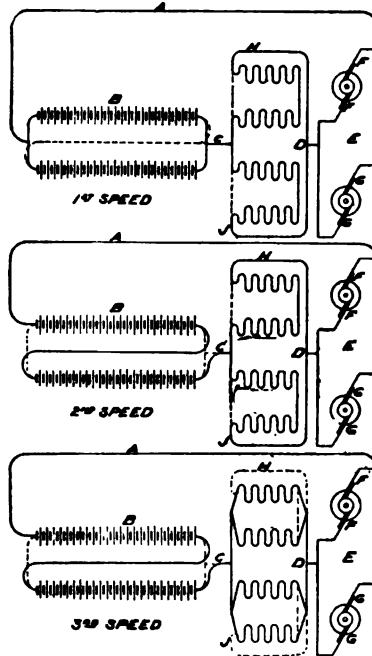

FIG. 440.—Diagram of the Circuit-Changing Arrangements of a Typical Electrical Vehicle. The full lines in these plans indicate the closed, or active, circuits; the dotted lines the open, or inactive, circuits. As may be readily understood, the whole scheme of circuit changing depends on employing several different circuit connections between battery and motor, which may be opened and closed, as desired. Here *A* and *C* are the lead wires between battery, *B*, and motor brushes, *FF* and *GG*, and the field-windings, *H* and *J*, and wire, *D*.

gives the lowest speed and power efficiency of the motors. By the wire, *D*, the current is carried to the brushes, *FF* and *GG*, which, according to this scheme, are permanently connected in multiple, the return path to the negative pole of the battery being through the wire, *A*.

In the second figure of the diagram the circuit is varied so as to connect the two units of the batteries, so as to give its highest pressure efficiency. But, since the field windings of the motors are also connected in series, or in series-parallel, as in this case, the efficiency in speed and power is reduced nearly one-half.

In the third figure the two units of the battery are connected in series, which, as in the former case, indicates the greatest efficiency in power output; but the field windings are connected in parallel, which means that the C. E. M. F., generated by their operation, is equivalent to the C. E. M. F. of only one motor, with the result that the speed and power efficiency is raised to its highest point.

Diagram of Battery, Motor and Controller—In the second diagram, illustrating a typical method of shifting the circuits, we have the same general scheme applied, so far as the first, second and fourth speeds are concerned, the connections of the controller being laid out in rectangular form between the broken lines. When the controller is rotated, so that the row of terminal points, *A, B, C, D, E, F, G*, are brought into electrical contact with the row of terminal points, on the controller, *A', B', C', D', E', F', G'*, we have the first speed forward, which, as may be readily discovered by tracing the connections throughout, involves that the two-unit battery is connected into multiple and the field windings of the two motors in series. Tracing the connections indicated for the second speed, we see that the terminal points, *A, B, C*, etc., are brought into electrical contact with *A', B', C'*, etc., and we have the batteries in multiple and the fields in series-multiple. Tracing the connections indicated for the third speed, we have the terminal points, *B* and *C*, connected to the terminal points, *B'* and *C'*, and the terminal points, *E* and *F*, connected to the terminal points, *E'* and *F'*, which means that the batteries are connected in series and the fields in series. Similarly, by tracing the connections for the fourth speed, we find the terminal points, *B* and *C*, connected to terminal points, *B'* and *C'*, and the terminal points, *D, E, F, G*, in electrical connection with the terminal points, *D', E', F', G'*, which means that the batteries are in series and the fields in multiple. The connections between the battery, the armature brushes and the motor fields, are made as indicated through the

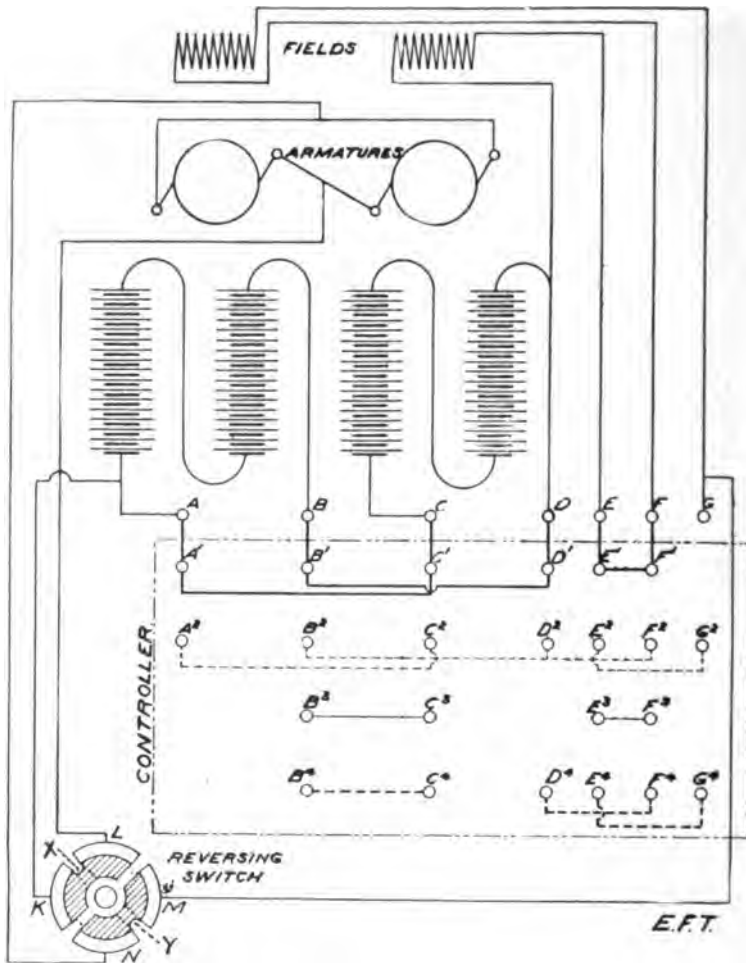

FIG. 441.—Diagram Plan of the Several Parts of an Electrical Vehicle Driving Circuit. The field-windings and armatures are shown projected, the proper wiring connections being indicated. The periphery of the controller is laid out within the broken line rectangle, the contacts and connections through it for varying the circuits through four speeds being shown. A, B, C, D, E, F, G are the terminal contact points of the various speed circuits, to be made as the positions of the controller contacts are varied. A', B', C', D', E', F' are the controller contacts, which, with those already mentioned, make the proper circuits for the first speed. Similarly, A'', B'', C'', etc., when brought into contact with A, B, C, etc., give the second speed circuits; B'', C'', D'', E'', F'', G'', in contact with A, B, C, D, etc., give the third speed; and B''', C''', D''', in the same manner, the fourth speed. The reverse switch gives the backward movement, as described.

rotary reversing switch, by the terminals, *K*, *L*, *M*, *N*. This switch may effect the reversal of the motors by giving a quarter turn to its spindle, which means that the contacts of segment, *X*, will be shifted from *L* and *K* to *K* and *N*, and the contacts of segment, *Y*, shifted from *M* and *N* to *L* and *M*, thus reversing the direction of the current.

Electric Vehicle Company's Circuits.—Some leading manufacturers of electric vehicles, notably the Electric Vehicle Co.,

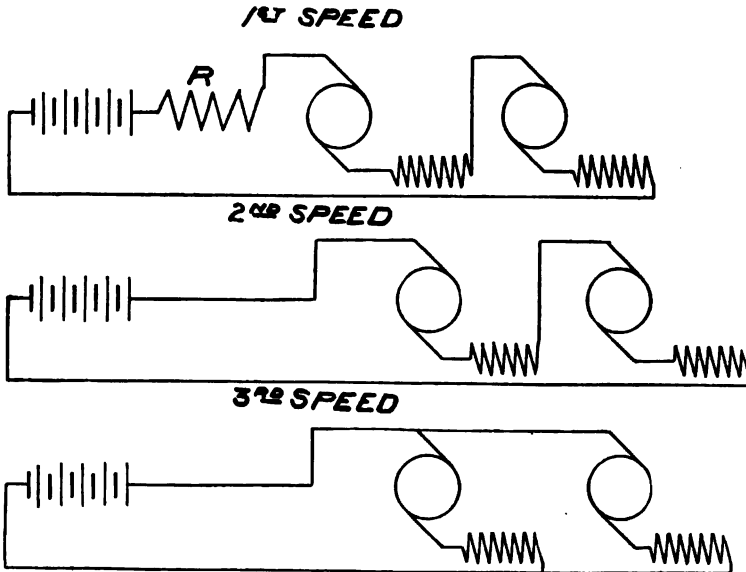

FIG. 442.—Diagram of a Typical One-Battery-Unit, Two-Motor Circuit. The first speed shows the two motors *in series*, with a resistance coil interposed; the second, the motors *in series*, without the resistance; the third, the motors *in multiple*.

vary the scheme shown in the last two figures by connecting the armature brushes and fields of each motor into series, and shifting the circuit connections, where two motors are used, from series to series-parallel. In the figure showing the combination of one battery unit with two motors, the connections for the three speeds obtained are obvious. Since only one unit is used, the lowest pressure of the battery can be obtained only by inserting a resistance coil, *R*, in the circuit, with the armature brushes,

field windings and both motors connected in series. For the second speed the resistance is simply cut out, allowing the full voltage of the battery to pass through the armatures and windings of both motors, still connected in series. For the third speed the connections of armatures and motors are shifted to multiple, or series-multiple. With the use of a two-unit bat-

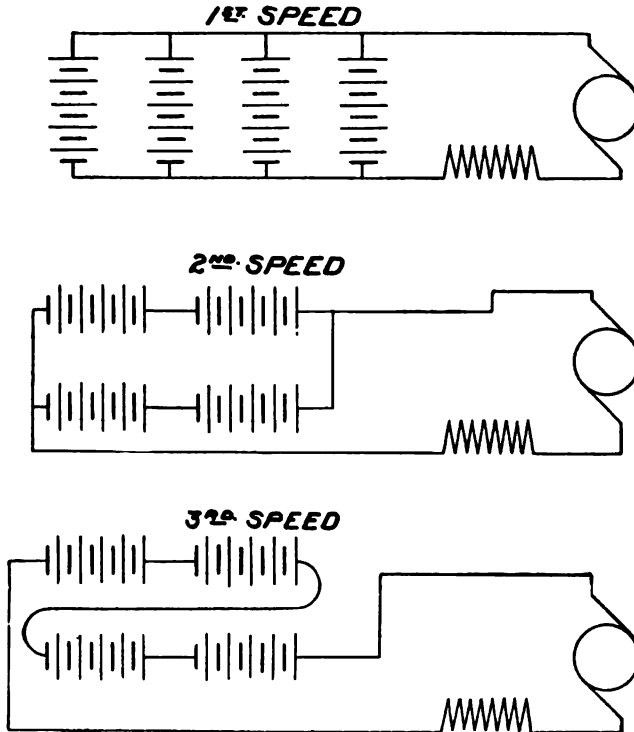

FIG 443 — Diagram of a Typical Four-Battery-Unit, Single-Motor Circuit, showing combinations for three speeds. The only changes made in these circuits are in the battery connections. For the first speed the battery units are in *multiple*; for the second, in *series-multiple*; for the third, in *series*. The motor connections are not varied.

tery and two motors, it is possible to eliminate the resistance coil altogether and depend entirely upon circuit shifting regulating the voltage and power. Accordingly, for the first speed we have the batteries connected in multiple, and the armatures and windings of the two motors in series. For the second speed,

the series connections are adopted for both batteries and motors, while for the third speed the batteries are in series, with the motors in parallel.

A Four-Battery-Unit, One-Motor Circuit.—In the diagram indicating the use of four-battery-units with one motor, which, as shown in an accompanying cut, is used to drive both rear wheels of the wagon through a single reduction, it is possible to obtain

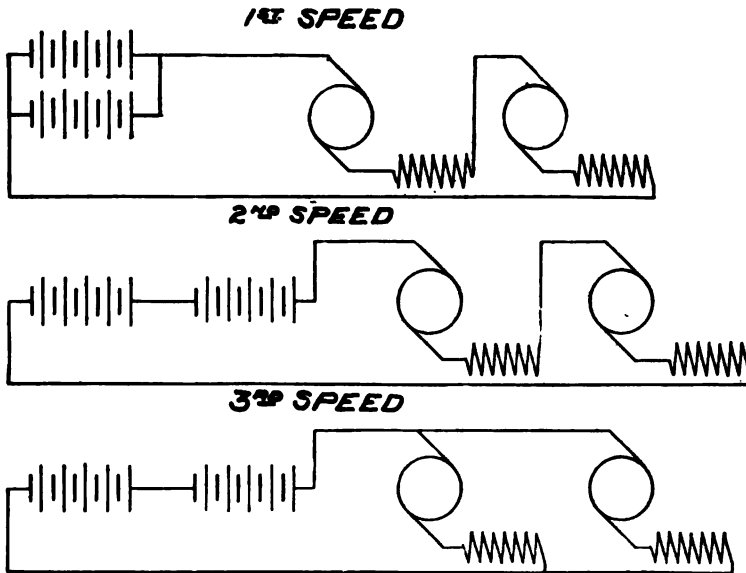

FIG. 444.—Diagram of a Two-Battery-Unit, Two-Motor Circuit, showing combinations for three speeds. The first speed is obtained with the battery units *in multiple*, and the motors *in series*; the second, with the battery units *in series*, and the motors *in series*; the third, with the battery units *in series*, and the motors *in multiple*.

a still greater range of variation by the simple shifting of the battery circuits, without alteration of the armature or field connections. Accordingly, for the first speed we have the four units connected into parallel, which gives a total voltage equivalent to the voltage of any one of them. For the second speed, the battery units are connected into series, the two pairs thus formed being joined in multiple, with the result that the total voltage of the battery is equivalent to the sum of the voltage of two of the

units, or twice the voltage used in the first speed. For the third speed, all four units of the battery are connected into series, thus doubling the voltage again, and realizing the highest speed and power efficiency possible in the combination. It might be possible to further vary the connections shown in any of these figures so as to obtain different speed and power combinations, but the limit of safe operation of the motor is generally pretty accurately calculated, and any further variations in the circuits might not be warranted.

The Controller of an Electric Vehicle.—The controller of an electric vehicle consists of a rotatable cylinder, carrying on its

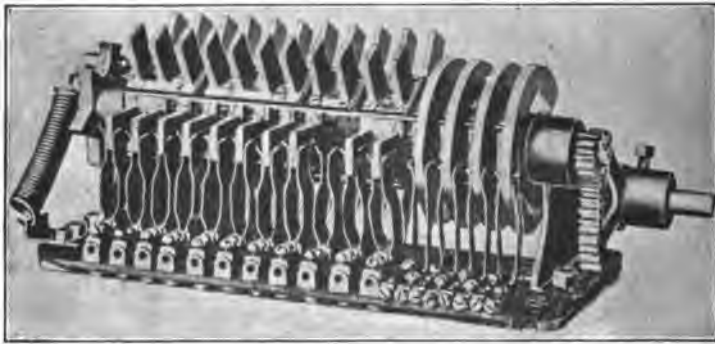

FIG. 445.—A Typical Electrical Vehicle Controller, or Circuit-Changing Switch. The circuit terminals of battery and motors are shown at the jack springs, which are arranged to be engaged by the fins on the periphery of the controller cylinder. The connections within the controller, between the fins, are, in general, the same as those shown in Fig. 448.

circumference a number of contacts, which are arranged to make the desired connections with the terminals of the various apparatus in the circuit through a wide range of variation. As shown in the figure of the arrangement of the battery and controllers in a typical electric vehicle, these points are arranged so that the units of the battery may be connected in series or multiple, and that the field windings of the motors may be similarly varied. As shown in the diagram, this act is accomplished by a series of variations of electrical connection among the contact points on the periphery of the controller. Thus we find that for the first speed, in which the batteries are connected in multi-

ple, the points, A' , C' , are in electrical connection, as indicated by the lines between them, so that the points, A , C , connected to the like poles of the two battery units, are directly connected, thus bringing the two units into multiple. The battery circuit is completed by the electrical connection on the controller between the points, B' and D' , when they are brought into contact with the points, B and D , which connect to the two other poles of the battery. Furthermore, the points, E' and F' , being in electrical connection through the body of the controller, connect points, E and F , direct; thus throwing the field windings of the motors into series.



FIG. 446.—"Columbia" Electrical Tonneau Carriage. The weight is about 2,800 pounds; the travel radius, about forty miles per full charge of battery; the maximum speed, thirteen miles per hour.

nect points, E and F , direct; thus throwing the field windings of the motors into series.

Construction of a Controller.—An accompanying cut shows the general appearance and construction of one type of controller for electric vehicles of moderate weight. As may be seen, the connections of the terminals of the batteries, of the field windings, and other elements of the circuit, are made at the binding posts at the front base of the instrument. From each of these binding posts, which are electrically insulated from one another, two jack-springs rise to a position convenient to make

connections with the switch blades arranged along the periphery of the controller cylinder. These switch blades, as may be seen, are secured to the controller cylinder by screw connections, being arranged singly, or several of them together on one plate. In the case of a pair of blades, shown in contact with the spring at either extremity of the controller cylinder, it is evident that there is an electrical contact, through the base plates, between the two terminals, represented by the contact springs in engagement. Between these two end plates, as may be seen, there are several switch blades arranged singly upon the circumference. At one point there is no contact whatever, showing that the terminals represented by the contact springs at that point are out of circuit. These several blades that are arranged singly on the controller surface have such electrical connections as the scheme of circuit variation adopted demands, made through insulated wire connections arranged between any pair it is desired to connect. This is the arrangement indicated in the diagram of connections already described. It is perfectly easy to understand, therefore, how the circuit arrangements of battery units and motor windings may be varied through any desired range of connections, by simply connecting their terminals through properly arranged and connected controller contacts.

Varieties of Controller.—The controller shown in the cut, already described, represents only one type of this machine. Some controllers are constructed simple, with a perfectly cylindrical surface, upon which bear single leaf springs, the desired electrical connections being made by suitably connected conducting surfaces on the cylinder circumference, and cut-outs being similarly accomplished by insulating surfaces bearing against the spring contacts at the desired points. The type of controller shown in the cut, however, is one of the most usual forms for motor vehicle purposes. As is perfectly obvious, it is possible to so arrange the electrical connections on the controller surfaces, that by proper contacts with the terminal springs, reversal of the motor may be accomplished. This is done in a number of controllers, the reverse being accomplished at a definite notch on the quadrant of the controller shifting lever.

CHAPTER FORTY.

THE CONSTRUCTION AND OPERATION OF STORAGE BATTERIES.

On Storage, or Secondary, Batteries.—As already stated, electric vehicles derive their power from storage batteries, which are charged from a suitable charging plant, supplying current either from the street power lines, or from the dynamo operated by any convenient source of power. The word, storage battery, as applied to electrical accumulators, or secondary batteries, is somewhat of a misnomer, since these devices are in no sense receptacles for electrical energy, and act on an entirely different principle from the instrument known as a condenser, which depends solely upon such variations of the electrical potential between two surfaces, that one of them may be so affected by the electrical current, momentary or prolonged, as to give forth electrical energy in the form of a shock, when brought into contact with any other surface having a low or negative potential. Such a device as this is, of course, useless for any purpose requiring a constant current between two points of different potential, such as is required for any kind of power transmission.

The so-called electrical accumulator, or storage battery, more properly to be described as a secondary battery, operates on an entirely different principle, which may be briefly described as an electro-chemical one, by which an electric current, steadily flowing through a given period, can produce certain chemical changes, which, as the expression is, "form" the battery. This process may be briefly illustrated by making a comparison with a primary galvanic cell. In the typical primary cell, two metal electrodes, as, for example, copper and zinc, are placed in a liquid electrolyte, such, for example, as dilute sulphuric acid. As soon as the two electrodes, thus immersed in the liquid, are connected so as to form a complete circuit between them through the liquid and back again through the outside wire, an electrical current, which is to say, a continuous transmission of electrical energy, is set up between them on the outside wire. This phenomenon takes place in accord with what may be called the specific potential of the two metals; copper having a higher ca-

capacity for being affected by electricity, and, hence, being capable of constantly imparting its charge to the zinc electrode, which represents a specifically lower electrical potential, or a smaller capacity to be affected by and retain electricity.

With the secondary battery both electrodes are constructed of the same material, the difference in potential, upon which the production and transmission of the current depends, being produced entirely through the chemical changes, resulting from the electric current flowing through the electrolyte between the two poles of the battery, during a long period of time. In practically all secondary batteries both the positive and negative electrode plates are formed of lead, or some composition of lead, and the electrolyte, as in many primary cells, is dilute sulphuric acid.

The General Theory of Storage Batteries.—The general theory upon which a secondary battery operates was discovered as early as 1801, when Gautherot discovered that if two electrode plates of platinum or silver, immersed in a suitable electrolyte, are connected to the terminals of an active primary cell and current is allowed to flow for any desired period, a small current could be obtained on an outside circuit connecting these two electrodes, as soon as the primary battery had been disconnected. The process which takes place in this case is briefly as follows: An electrolyte, consisting of a weak solution of sulphuric acid, permits ready conduction of the current from the primary battery, the greater the proportion of acid in certain limits the smaller being the resistance offered. The effect of the current passing through the electrolyte is the decomposition of the water, which is indicated by the formation of bubbles upon the exposed surfaces of both electrode sheets, these bubbles being formed by oxygen gas on the plate connected to the positive pole of the primary battery, and hydrogen on the plate connected to the negative pole of the battery. Because, however, the oxygen is unable to attack either platinum or silver under such conditions, the capacity of such a device to act as an electrical accumulator is practically limited to the point at which both plates are covered with bubbles. After this point the gases will begin to escape into the atmosphere. In this simple form of battery, as in the storage batteries manufactured at the present day, the

prime condition to operation, is that the resistance of the electrolyte should be as low as possible, in order that the current may pass freely and with full effect between the electrodes. If the resistance of the electrolyte is too small, the current intensity will cause the water to boil rather than to occasion the electrolytic effects noted above.

As soon as the current from the primary cell is discontinued, and the two electrode plates from the secondary cell are joined



FIG. 447.—Electric Victoria for Carrying Two Passengers. The weight of the carriage shown is about 2,100 pounds; its radius of travel about 40 miles per charge of battery; its maximum speed 13 miles per hour.

by an outside wire, a small current will be caused to flow upon that outside circuit by the recombination of the acid and water solution. The process is in a very definite sense a reversal of that by which the current is generated in a primary cell. Hydrogen collected upon the negative plate, which was the cathode, so long as the primary battery was in circuit, is given off to the liquid immediately surrounding it, uniting with its particles of

oxygen and causing the hydrogen, in combination with them, to unite with the particles of oxygen next adjacent, continuing the process until the opposite positive plate is reached, when the oxygen collected there is finally combined with the surplus hydrogen, going to it from the surrounding solution. This chemical process causes the current to emerge from the positive plate, which was the anode, so long as the primary battery was in circuit. The current thus produced will continue until the re-composition of the gases is complete; then ceasing because these gases, as before stated, do not combine with the metal of the electrodes.

Requirements in a Practical Storage Battery.—In order to produce a secondary battery that shall be able to give forth a current of sufficient strength and duration for practical purposes, it is necessary to employ some metal that can be attacked by the oxygen produced in the process of "charging," but which at the same time is capable of being restored to its normal condition when the operation is reversed. It therefore follows that the simplest possible form of storage battery consists of two sheets of metallic lead immersed in an electrolyte of dilute sulphuric acid. When a current from a primary battery is passed through the electrolyte between the two lead sheets, the same process takes place as was described in connection with the cell formed with platinum sheets. Oxygen and hydrogen, liberated by electrolysis, collect upon the surface of the two plates, thus forming the electro-chemical basis for the production of a current from the battery, so soon as the primary electrical source is disconnected. The operation differs, however, from that formerly noted, in the fact that oxygen bubbles do not appear upon the surface of the anode, but the presence of the gases is manifested rather by a chemical change in the plate. The oxygen attacks the lead, forming lead peroxide.

The Planté and Other Early Cells.—By disconnecting this battery from the primary source a weak current can be produced until the normal conditions have been restored, as previously explained; but, in order to prepare such a battery for any kind of practical use, it must be suitably "formed," which process consists briefly in rapidly changing the direction of the charging

current, and allowing the battery to be practically discharged. By changing the direction of the current, so that the anode or positive terminal is made the cathode or negative terminal, and vice versa, the following series of changes take place: The lead peroxide collected on the surfaces of one of the sheets, gradually disappears, as indicated by the change in the color of the plate

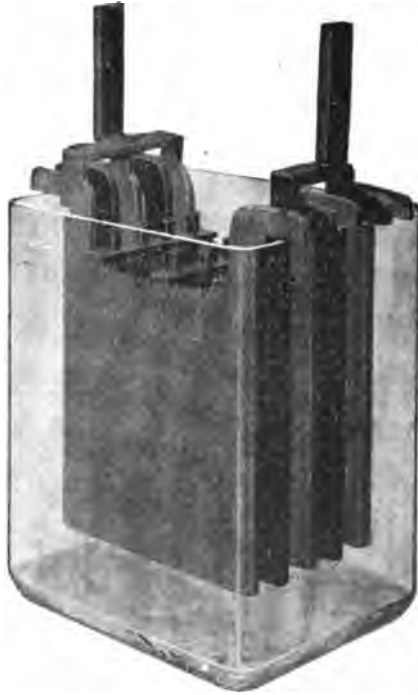

FIG. 448.—A Typical Storage Cell Enclosed in a Glass Jar. This cell represents one of the best-known makes of the Planté genus. With five plates, as shown, such a cell has a capacity of 80 ampere-hours, at 8 hours' discharge; of 70 ampere-hours, at 5 hours' discharge; of 60 ampere-hours, at 3 hours' discharge; with a discharge rate of 10 amperes in 8 hours; of 14 amperes in 5 hours, and of 20 amperes in 3 hours. The total outside dimensions of this cell are $5\frac{1}{4} \times 9\frac{1}{4} \times 11\frac{1}{4}$ inches; dimensions of each plate's active surface, $7\frac{3}{4} \times 7\frac{3}{4}$ inches.

from brown to lead metallic. The peroxide, however, gradually begins collecting on the surface of the other plate, and so continues so long as the current endures. The plate from which the peroxide has been separated, by repeated alternations of the charging current, assumes a spongy character, which enables the

increasing of its electrical accumulating property by increasing the surfaces exposed to the attacks of the oxygen gas. This process of "forming" by repeated alternations of the charging current, was the plan adopted in the earlier types of the Planté storage batteries, which, but for this tedious process, had a high power rating. As has been stated by several competent authorities, the average power output of the earlier types of the Planté cell was $7\frac{1}{2}$ ampere-hours per pound of lead, which is as high as any that has since been achieved. The process of "forming," however, according to the same statement, rendered the plates very nearly rotten by the time the maximum capacity had been achieved. As a consequence of the expense and difficulty incident to the "forming" process, the later types of the Planté cell are composed of plates formed by pickling baths of 50 per cent. solution of nitric acid. After an immersion of from 24 to 48 hours in this solution, the plates are treated with a 10 per cent. solution of sulphuric acid, or by a thorough washing in ammonia, followed by heating in a furnace to a temperature of 203 degrees Centigrade. After this the plates are in condition to be used in a practical secondary battery, the process and conditions of charging being essentially the same, as have already been described.

Varieties of Storage Battery.—At the present time storage batteries are made along two general lines: (1) those following the Planté type, on which the negative and positive must be suitably "formed," usually by some process of "pickling," as already described; (2) those in which the positive and negative plates are made by using different chemical substances in their formation at the start.

The Planté Genus of Battery.—A typical storage battery of the first class is shown in the several accompanying illustrations. Here, both the positive and negative plates are shown as constructed with a large number of deep parallel grooves, which are cut by means of a special tool. This process is termed "spinning." In order to "form" the battery the plates, thus suitably grooved, are placed in a strong oxidizing solution, generally ammonia nitrate, after which the current is passed through the solution transforming the oxides into peroxides. Both the positive

and negative grids are similar in construction, the principal difference in the start consisting merely in the chemical and electrochemical treatment. With the plates intended for use as negatives, all trace of nitrates is carefully washed out. Plates intended for positives are reformed in a sulphuric acid electrolyte. After these processes, the positive and negative plates may be assembled into storage cells, the connecting necks being burned on, so as to connect all positives and all negatives to their respective terminals. As shown in accompanying illustrations,



FIG. 449.—“Unformed” Plate of One Pattern of “Gould” Storage Cell. The particular plate here shown has total outside dimensions of 6 × 6 inches. The clear outline of the grooves indicates absence of oxides due to action of “forming” solutions, or charging current.

the cells formed by a number of these plates—an odd number of positives and an even number of negatives—have sheets of porous hard rubber between each pair of plates.

With batteries of this make, intended for use in electric vehicles, a voltage output of from eight to ten watts per pound of total battery weight may be realized. The duration of its period of usefulness is also considerably longer than that realized in many other types of cell, which is a quality claimed for several of the most representative batteries of the Planté genus.

The Second Type of Storage Cells.—The second type of storage battery is that in which the positive and negative plates are made separately, the chemical difference between the two being furnished by the use of diverse chemicals at the start. Another well-known type of American storage battery, which is fairly representative of this class, is made as follows: The positive plates or “grids” are composed of an alloy of lead and antimony, cast into shape with a certain number of round perforations. Each of these holes is then filled with a button, made by rolling a crimped lead ribbon into a coil of proper size to fit it tightly. By an electro-chemical process, the required lead oxide is then produced. The negative grids are made by casting the proper shape, under heavy pressure, around a number of square blocks of fused chloride of zinc and chloride of lead. When the grid is completed, the zinc is chemically removed, leaving the contents of each perforation pure spongy lead. The plates are now ready to be assembled into a cell and to begin work as soon as the current has been passed through the electrolyte composed of a solution of sulphuric acid.

Points on Care and Operation.—On the manner of operating and maintaining storage batteries for use in electric vehicles and for other purposes, there are a number of points to be considered. However, it is necessary for the purpose of this book to deal with only a few of them. In the first place, it is frequently necessary for persons owning and operating storage batteries to renew the electrolyte. It is, therefore, desirable that they should understand the proportions of the solution and the manner of preparing it. The solution generally consists of five parts of distilled water to one of concentrated sulphuric acid, by volume. For some makes of battery the proportion is fixed as 8 to 1. The mixture should be made by pouring the acid slowly into the water, never the reverse. As cannot be too strongly stated, *it is very dangerous to pour the water into the acid*, and too much care cannot be exercised on this score. As given by several authorities, the solution of acid and water when properly mixed should show a specific gravity of 1.190 by scale of the ordinary commercial hydrometer. The electrolyte should never be mixed in jars containing the battery plates, but preferably in stone crocks, specially prepared for the purpose. Since after

mixing, the solution gives off considerable heat, it should be allowed to cool for at least four hours.

In preparing electrolytic solutions, care should always be taken that the water used is pure as possible, distilled water being preferable. River and well water should never be used for this purpose, since it contains certain salts of chlorine and ammonia, which are apt to seriously affect the plates and shorten the life of the battery.

Placing the Electrolyte in the Jars.—In placing the electrolyte in jars containing the cells, special care should be taken

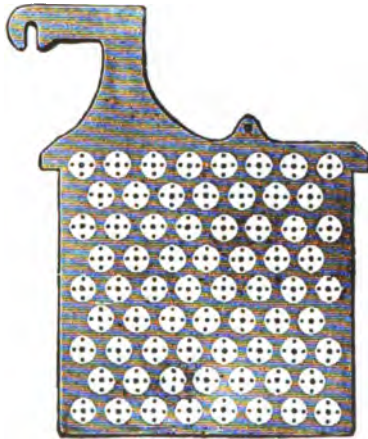

FIG. 450.—One Plate, or "Grid," of a Type of Storage Cell constructed by inserting buttons or ribbons of the proper chemical substances in perforations. Some such cells use crimped ribbons of metallic lead for inserting in the perforations, others pure red lead or other suitable material.

that the entire active surface of the grids are completely submerged. They should always be at least one-half inch below the surface of the solution. Whenever it is necessary to renew the electrolyte this rule should be observed, and so long as the batteries are in operation the level should never be allowed to fall below the points specified. In charging a storage battery, it is of prime importance that the connections with the generator be properly arranged. This means that the positive pole of the generator should be invariably connected to the positive pole of the secondary battery—which is to say, the pole which is positive in action when the current is emerging from the sec-



FIG. 451.

FIG. 451.—Specimen Negative Plate of a Type of the "Gould" Storage Battery, showing the result of "formation" in the changed appearance of the plate surface.

FIG. 452.—Specimen Positive Plate of a Type of the "Gould" Storage Battery, showing the changed appearance of the plate surface, due to "formation."

FIG. 452.

ondary battery, or the pole that is connected to the positive plates. As this is a matter of prime importance, the exact polarity of both generator and secondary battery should be accurately determined before attempt is made to charge. An error in this particular will result in entire derangement of the battery and its ultimate destruction. In charging a storage battery for the first time it is essential that the current should be allowed to enter at the anode or positive pole at about one-half the usual charging rate prescribed; but after making sure that all necessary conditions have been fulfilled, it is possible to raise the rate to that prescribed by the manufacturers of the particular battery.

Period of Charging a New Battery.—With several of the best known makes of the American storage battery the prescribed period for the first charge varies between twenty and thirty hours. The manufacturers of the Gould battery recommend that for the first charge half rate be maintained for four hours, after which the current may be increased to the prescribed normal power and continued for twenty hours successfully.

The strength of current to be used in charging a cell should be in proportion to its own rate of capacity. Thus, as given by several manufacturers and other authorities, the normal charging rate for a cell of 400 ampere hours should be fifty amperes. Before closing the charging circuit it is essential that the voltage of the generator should be at least ten per cent. higher than the normal voltage of the battery when charged. The fact that a storage cell is fully charged is evident by the apparent boiling of the electrolyte and a free giving-off of gas. It may also be determined by testing the battery with a voltmeter, which will show whether the normal pressure has been produced. At the first charge of the battery, the voltage should be allowed to rise somewhat above the point of normal pressure, but thereafter should be discontinued at a specified point. At the first charging of a cell, when the pressure has reached the required limit, the cell should be discharged until the voltage has fallen to about two-thirds normal pressure, when the cell should again be recharged to the normal voltage.

Changed Specific Gravity of the Electrolyte.—Another effect resulting from the first charging of a storage cell is a change

in the specific gravity of the electrolyte. According to the figures already given, this should be about 1200, when the solution is first poured into the cells. At the completion of the first charge, it should, on the same scale, be about 1225. If it is higher than this, water should be added to the solution until the proper figure is reached; if it is lower, dilute sulphuric acid should be added until the hydrometer registers 1225.

In charging a storage cell, particularly for the first time, it is

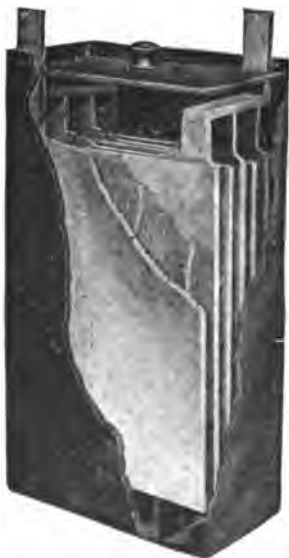

FIG. 453.—One Cell of the "Gould" Storage Battery for Electric Vehicle Use. According to the data given by the manufacturers, this cell, containing four negative and three positive plates, has a normal charging rate of 27 amperes; a discharge rate of $2\frac{3}{4}$ amperes for 4 hours; a capacity of 81 ampere-hours at 3 hours' discharge, and of 90 ampere-hours at 4 hours' discharge. The plates are each $5\frac{1}{8} \times 7\frac{3}{4}$ inches, and the total dimensions of the cell, enclosed in its rubber jar, are $2\frac{1}{2} \times 6\frac{1}{4} \times 11$ inches. Forty such cells are generally used for an average light vehicle battery.

desirable to remember that a weaker current than that specified may be used with the same result, provided the prescribed duration of the process be proportionately lengthened. The battery may also be charged beyond the prescribed voltage, ten or twenty per cent. overcharge affecting no injury occasionally; although, if frequently repeated, it seriously shortens the life of the battery.

Another point of importance touches the question of maintaining the charge of the battery. Even if the use is only slight, in proportion to the output capacity, the battery should be charged at least once in two weeks, in order to maintain it at the point of highest efficiency. About as often a battery should be charged at slowest rate, the charging current being adjusted to complete the charge only in twenty or thirty hours.

In charging a storage battery, it is essential to remember the fact that the rate of charge is in proportion to the voltage of the battery itself. Thus, a 100-ampere-hour battery, charged from a 110 volt circuit, at the rate of ten amperes per hour, would require ten hours to charge, and would consume in that time an amount of electrical energy represented by the product of 110 (voltage) by ten (hours), which would give 1,100 watts.

Results of High Rates of Charging.—In charging a battery at a high rate, the danger to be avoided is the tendency of the cells to heat. The troubles that might arise from this cause may be prevented by immediately reducing the current strength. The proper rate of charge for a given battery of cells may be thus discovered by experiment. A battery should never be charged at a high rate unless it be completely exhausted, since it is a fact that the rate of charge that it will absorb is dependent upon the amount of energy already absorbed.

As given by a well-known authority, a type of cell, whose make and capacity is specified by him, may be charged at the following rate in 45 minutes: 140 amperes for the first 20 minutes; 100 amperes for the next 5 minutes; 70 amperes for the next 5 minutes; 30 amperes for the next 10 minutes; 10 amperes for the last 5 minutes. This is the rate to be followed when the battery is completely discharged. The same authority gives for the same battery the following figures for full charging in three hours: For the first half hour, 70 amperes; for the second, 40 amperes; for the third, 30 amperes; for the fourth, 20 amperes, and during the last hour, 10 amperes.

These rules are imperative, and a current of a given strength should not be continued over the time specified in the directions, nor after the voltmeter records a pressure of 2.6 volts per cell.

CHAPTER FORTY-ONE.

ON THE CONSTRUCTION AND OPERATION OF BRAKES ON MOTOR CARRIAGES.

General Requirements in Brakes.—An important subject in connection with the construction and operation of motor vehicles relates to the brakes used for retarding the movement of the carriage when it is desirable to either come to a more or less sudden stop, or to hold the carriage stationary on the side of an incline. Several conditions are essential to the designing of brakes for motor carriages, among which we may mention ease and rapidity of operation and the maximum of braking effect, with the minimum of power exerted at the operating lever.

Varieties of Construction in Brakes.—There are two kinds of brakes in familiar use on vehicles of all descriptions: Shoe brakes, which operate by the pressure of the contact surface or shoe upon the periphery of the wheel tire, and drum brakes, which operate by tightening a band around a drum, either on the hub of the wheel or on the case of the differential gear. Both varieties are used to a considerable extent on motor vehicles, although most authorities agree that shoe brakes are unsuitable for use on wheels tired with pneumatic tubes. The reason given for this opinion is that the constricting effort due to pressing the shoe against the tire is, like the ordinary shocks experienced in travel, largely absorbed by the tire itself, with the result that it is liable to be rent or torn from its attachment to the rim. On the other hand, it has been asserted by at least one well-known manufacturer of motor vehicles that shoe brakes may be safely and satisfactorily used on pneumatic-tired wheels, provided the surface contact of the shoes extend over a sufficiently extensive arc to prevent the strain from being concentrated on small areas of the circumference. This authority asserts that he himself has used a motor tricycle for several years, the wheels of which are equipped with a shoe brake constructed according to his idea. The result is, he states, that the contact surface of the shoe has been worn much more rapidly than the tire surface, which seems to suffer very little, if any, more than would be the case with the

use of any other form of brake. Whether his experience in this regard would be borne out in general practice, it is not necessary to inquire, the fact being that nearly all motor vehicles at the present time operate with drum and strap brakes.

Principles of Band Brake Operation.—Among the advantages possibly to be alleged for the drum and band brake we may enumerate the facts that, with ordinary connections, they are much more readily operated and with much greater effect while on any showing involving a minimum of wear on the moving parts. As may be readily understood, the operation of the drum and band brake is a reversed application of the principle of torque, as already explained in connection with the electrical motor. As there explained, if the power acting upon a rotating shaft be equal to the weight of fifty pounds constantly applied, and the pulley attached to the shaft be twice the diameter of the shaft, the available power at the periphery of the pulley will be just one-half that exerted on the periphery of the shaft itself. This statement is equivalent to saying that if a rope carrying a weight of fifty pounds be wound about a pulley, whose diameter is one foot, mounted on a shaft, whose diameter is six inches, it will exactly balance a weight of one hundred pounds on a rope wound about the shaft. The constantly applied power of slightly over twenty-five pounds at the periphery of the pulley will be sufficient to rotate the shaft against a resistance of fifty pounds on the shaft. It thus appears that the braking power, applied around the periphery of the brake drum, is efficient in retarding the momentum of a forward-moving vehicle in very nearly the inverted ratio existing between the diameters of the drum, or pulley, and the rotating shaft to which it is attached. In the practical application of this principle, however, it is obvious that there must be very definite limits to the diameter of the brake drum, or pulley, beyond which it would be undesirable to go. According to the practice adopted by light motor vehicle manufacturers, the average diameters of brake drums range between eight inches and two feet, the principal item of variation in this respect being the weight of the vehicle itself.

Beaumont's Formulæ for Brakes.—It is possible to obtain a very efficient band brake on a very moderate diameter of drum,

owing to the fact, which need scarcely be mentioned, that the braking effort is never applied until the motive power is disconnected from the running gear. In a steam vehicle, the first act is to shut off the steam from the cylinder; in a gasoline vehicle, to throw off the main clutch; in an electrical vehicle, to open the circuit of the motor and batteries. The resistance against which the brake must then operate is found to be purely a consideration

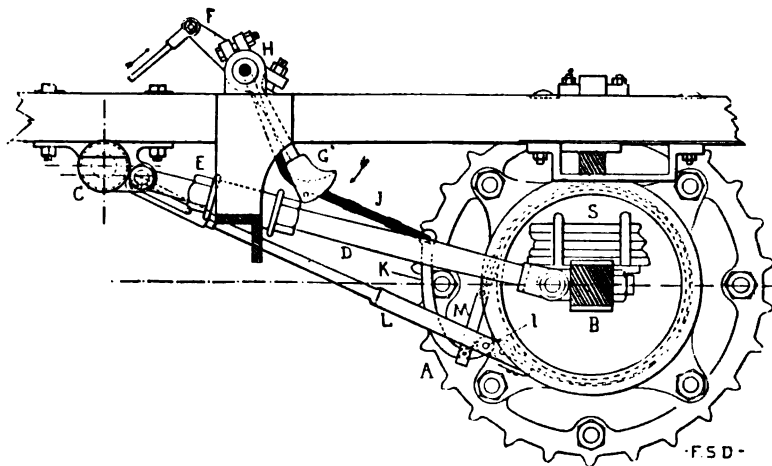

Fig. 454.—The Hub Brake and Operating Levers Used on the Panhard Carriages.—The arm, F, being pushed in the direction of the arrow, causes the arm, G, on the same pivot, H, to move in the opposite direction, as indicated by the lower arrow. Through this arm, G, runs the cable, J, as shown, which, pulling on the arm, K, pivoted at I, pulls the strap, shown by dotted lines around the drum, S. The other end of the strap attached to the short arm of the lever, K, is thus drawn toward the same point, a tight frictional bind being the result.

of the vehicle's weight, its velocity and the acceleration due to gravity. This principle is already stated by Mr. Beaumont, as follows:

"When it is necessary to determine the brake power to stop a vehicle of a given weight running at a given speed, in a given distance, and, by this means, arrive at something like due comprehension of the necessary parts brought into play to effect this stop, it must first be pointed out to those who overlook the fact, that the strain put upon a brake to effect a stop in a given distance increases as the square of the increase of speed; so that to stop a car running twenty miles per hour requires four times

the power necessary to stop it in the same distance when running ten miles per hour. Commonly, all calculations relating to the acceleration of masses at high speed are calculated on the basis of distance covered in feet per second, and hence the work or energy lodged in a mass having a given weight and moving at a given velocity in feet per second is given by the following expression:

$$K = \frac{W v^2}{2g}$$

in which *K* represents the work, or energy, lodged in the moving mass; *W* represents its weight; *v*, its velocity, expressed in

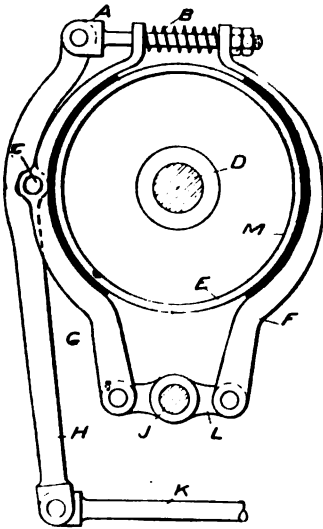

FIG. 455.

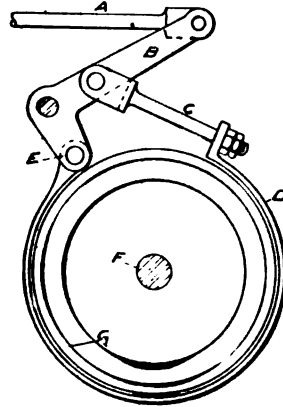

FIG. 456.

FIGS. 455 and 456.—Two Forms of Constricting Band Brake. In the first figure, the drum, E, rotates on the spindle, D. Two shoes, F and G, joined to the link, L, pivoted at J, are pressed against the periphery of the drum, E, when the link, K, moves the lever, H, pivoted at C, so as to pull the arm, A, on F, by compressing the spring, B, normally holding them apart. In the second figure, the band, D, surrounding the drum, G, is drawn tight, when the link, A, operates the bell crank, B, thus producing a pull through its attachments at C and E.

feet per second, and *g*, the acceleration due to gravity, or 32.2 feet per second.”

From the above formula, Mr. Beaumont proceeds to derive other essential elements, such as the efficient power necessarily

applied to stop a vehicle of given weight, in a given length of travel.

Reducing the expression for feet per second to miles per hour, according to the usual standard, and, assuming the weight of the vehicle to be one ton (of 2,240 pounds), he reduces the formula, as follows: One mile being 5,280 feet, and one hour, 3,600 seconds,

$$1 \text{ mile per hour} = \frac{5,280}{3,600} = 1.466 \text{ feet per second.}$$

$$\text{Whence } \frac{W v^2}{2 g} = \frac{W \times (1.466)^2}{64.4} = \frac{W \times 2.15}{64.4} = W \times 0.0334.$$

Then a vehicle weighing one ton, traveling at ten and twenty miles per hour, by the formula,

$$K = W V^2 \times 0.0334,$$

in which V represents miles per hour, will be for 10 miles $2,240 \times 100 \times 0.0334 = 7,480$ foot pounds; for 20 miles $2,240 \times 400 \times 0.0334 = 29,920$ foot pounds.

To Find Distance in Which Brakes Will Act on Vehicle's Speed.—Then, taking k as the coefficient of friction between the tires and road surface, which is approximately 0.60 for rubber tires; and taking W as the proportion of the total weight carried by the wheels to which the brake is applied, which may be assumed to be 0.6 of the whole, the maximum distance required to stop the vehicle on the level, on an ordinary road, whose surface resistance is, supposedly, included in the expression, k , may be expressed by l , as follows:

$$l = \frac{W V^2 \times 0.0334}{k w}$$

Then, for a vehicle weighing one ton, tired with average rubber tires, traveling at a momentum of 10 and 20 miles per hour, respectively, we have:

$$l = \frac{7,480}{0.6 \times 1,344} = 9.3 \text{ feet at 10 miles, and}$$

$$l = \frac{29,920}{0.6 \times 1,440} = 37.1 \text{ feet at 20 miles ;}$$

these distances representing the maximum, with a braking effect sufficient to cause the wheels to skid.

To Find the Required Braking Pull.—In order to find the necessary pull, p , on the brake band, the following formula is given:

$$p = k w = \frac{W V^2 \times .0334}{l}$$

which for one typical vehicle, moving at 20 miles per hour, gives,

$$p = \frac{29,920}{37.1} = 806 \text{ pounds.}$$

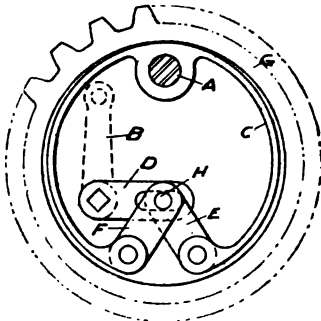

FIG. 457.

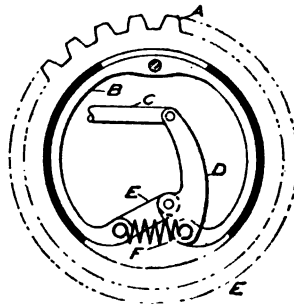

FIG. 458.

Figs. 457 and 458.—Two Forms of Expanding Band Brake. In the first figure, the gear, G, has an internal bearing surface, within which is the band, C, pivoted at A, a point separate from G. The arm, B, of the bell crank, B D, being moved to the left, spreads apart the two links, E and F, connected to D at H, thus pressing both ends of the band, C, against the internal bearing surface of G, and producing the necessary braking friction.

In the second figure, the gear, A, similarly arranged with an internal bearing surface, contains the expanding band, B. When the link, C, is pulled, the lever arm, D, double-pivoted at E and F, causes the two ends of the band, B, to press against the internal bearing surface of A, thus creating friction. The spring shown normally holds the two ends of the band apart.

Varieties of Drum and Band Brake.—As shown by accompanying illustrations, there are two general types of drum brake, the first consisting of a drum or pulley, around the circumference of which is a metal strap faced with leather, which is drawn tight whenever it is desired to furnish the resistance necessary to check the rotation of the shaft; and expanding band brakes, in which a similar metal strap, faced with leather or other suitable substance acts against the internal surface of a rotating drum or pulley. The former type is, however, at the present time the most usual construction, although the latter is seeing an increasing popularity.

In some forms of constricting band brakes, instead of a metal strap extending entirely around the drum, two shoes pivoted at a certain point, and having their inside faces faced with leather, are tightened against the drum by a suitable lever. In practically all forms of expanding band brake the band is attached to the outside frame, at one point of its circumference, and is suitably tightened by a toggle joint operated by a lever. This is the plan adopted in the several types shown in the accompanying illustrations.

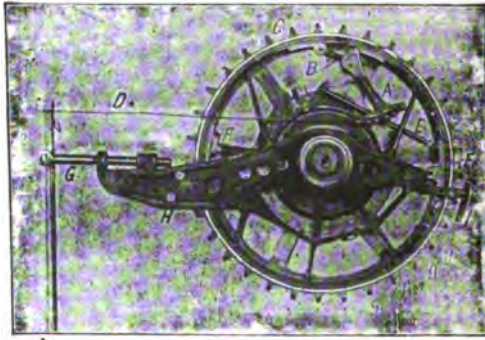

FIG. 469.—The "Duryea" Expanding Break. The two ends of the metal band are separated by the lever, A, and the adjusting screw, B, which is swiveled to the hinge, C. A forward pull on lever, A, through the chain pull, indicated by D, causes the two ends of the band to be thrust apart and bear against the inner surface of the sprocket. The extension spring, E, normally holds the band away from this friction surface. The two lugs, FF, attached to a spider hung on the axis of the sprocket, take the braking effort from the bottom of the band more into the line of travel. A framework, indicated at H and I, supports a leather guard covering both the chain and sprocket.

The Care of Brakes.—In successfully operating a motor carriage it is particularly essential that the brakes should be maintained in good working order. This involves that the levers and connections should at all times operate perfectly, and that no worn or loose bearings should be neglected. Furthermore, and most important, the friction surface between the band and the drum should be constantly and carefully guarded from oil deposits, which will certainly render the braking effort useless. If oil collects between the band and the drum surface it may be cut out with gasoline, and the parts then carefully wiped with a suitable rag.

CHAPTER FORTY-TWO.

ON BALL AND ROLLER BEARINGS FOR MOTOR CARRIAGE USE.

The General Uses of Rotative Bearings.—The practical problems involved in the construction of bicycles and motor carriages have given a great popularity to ball and roller bearings for use in connection with almost every variety of rotating shaft. As we have already seen in several constructions mentioned in previous parts of this volume, ball bearings are used in a large variety of different devices, in order to allow of the greatest possible ease in turning with the smallest friction and wear. The most important use, however, for ball and roller bearings, in both bicycles and motor carriages, is on the axles of the road wheels. For this purpose, although ball bearings are eminently satisfactory on the wheel axles and pedals of bicycles, they are for a number of reasons unsuitable for the heavier weights and higher speeds of motor carriages. Accordingly roller bearings have taken their place almost exclusively in this connection.

Rotating Supports vs. Sliding Surfaces.—The principal object involved in using ball and roller bearings on bicycles and motor carriages is to secure economy of traction effort, with ease and rapidity of driving, as well as a minimum of starting effort at the beginning of travel. A few simple principles will serve to fully explain the reasons for this fact. When we have a plain wheel bearing, such as is used on ordinary horse carriages, consisting of a simple tapered boss, with a similarly shaped hollow axle-box rotating around it, there is a considerable effort necessary at starting from rest, a good proportion of the power being consumed in resisting the friction between the sliding surfaces. This resistance is very largely due to adhesion between the two sliding surfaces, due to cohesion of the lubricating oil or grease. As a matter of fact, it may be easily understood that the sliding action of two round surfaces, one within another, may be readily compared to the sliding of one plane surface upon another. The first difference in point of resistance and effort necessary to overcome inertia, as between two such surfaces, when sliding against

one another directly, and when some kind of rollers or rotating supports are interposed, is a matter of the commonest experience. The heaviest objects may be readily moved or slid along the ground when rollers are placed beneath them; also the heaviest loads when carried on wheels of suitable breadth and diameter may be handled with a degree of ease, increasing directly as the ideal conditions are approximated. This principle is the very one that is applied in the practice of substituting ball and roller bearings for ordinary plain bearings. Instead of two plane surfaces having rollers interposed, the two surfaces are given a rounded contour, the one being within the other, and the same rule of increased ease of relative movement applies.

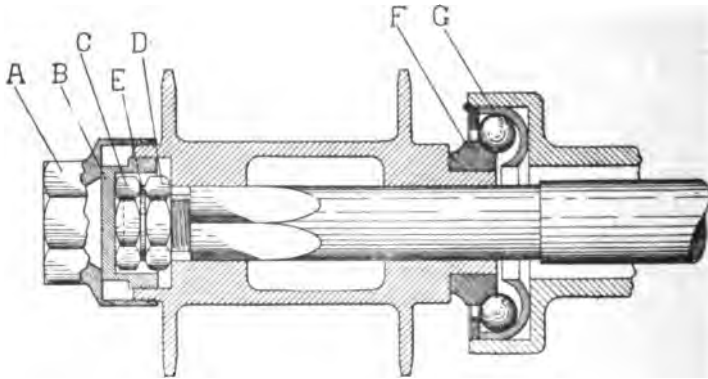

FIG. 460.—One Form of Driving Axle Using Ball Bearings. The hub is secured in place by the nuts and binders shown at A, B, C, D, E. At its inner extremity it carries a cone, F, which works on the ball race, G. The hub is thus suspended on the ball race, which also acts to neutralize end thrusts.

Rotative Bearings vs. Plain Bearings.—The obvious reason for the superior traction qualities obtained by the use of both kinds of rotative bearings is that the friction and resistance between the relatively moving surfaces is so greatly distributed that it is reduced to a practically negligible quantity.

One of the most familiar evidences of loss in power through the friction of the sliding surfaces, in plain bearing wheels, is seen in the fact that the hubs speedily become loose, greatly to the detriment of balanced rotation of the wheels and waste of traction effort. With properly adjusted ball or roller bearings this result is indefinitely delayed, even where it is not entirely obviated, and the wheels on which they are used not only give the

best results in point of tractive efficiency, but also in the duration of their period of usefulness.

The Limitations of Ball Bearings —Of the two varieties of rotative bearing, however, we may state on the authority of several writers on the subject that ball bearings have very decided limitations in point of useful operation as compared with cylindrical roller bearing surfaces. Balls have been successfully used on bicycles and numerous other constructions, but even at their

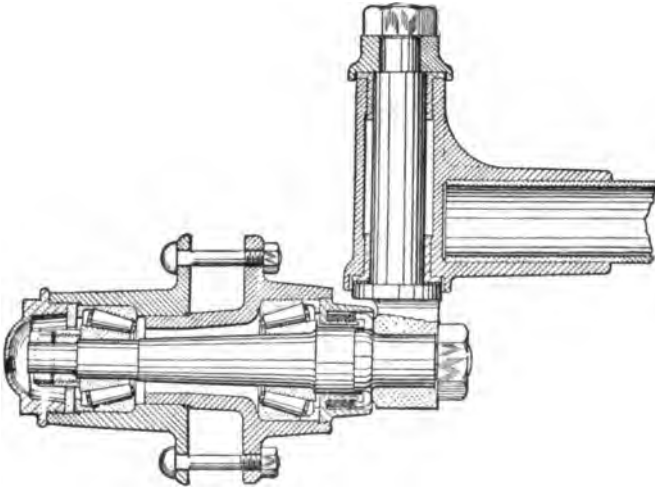

FIG. 461.—Stud Steering Axle showing Hub hung on Conical Roller Bearings. The shape of the bearings serves the double purpose of securing perfect rotative movement in forward travel; also to take up end thrusts.

best involve a considerable loss of power, owing to the fact that they roll in opposite directions and constantly rub against one another, with the result that the friction speedily wears them out, involving constant necessity of repairs. Furthermore, as the pressure of the load must necessarily come on one point only at a time, there is a limit to the weight which can be carried successfully without crushing one or several balls and jamming the ball race.

When the balls are confined by flat cones, heavy pressure upon single points causes crystallization and speedy deterioration. To remedy this defect some builders have curved the cones to fit the

balls as nearly as possible, with the result of reducing the wear, but increasing the friction, since there is then no longer a simple rolling action between the balls and cones. Others have adopted the plan of staggering the balls so that they travel upon different surfaces of the cones; but this expedient also involves considerable wear and friction of the ball surfaces, and crystallization follows much more speedily.

The Conditions of Using Roller Bearings.—Very largely from the reasons already enumerated, the roller bearings have come into almost universal use for the road wheels of motor carriages. As stated by a prominent manufacturer of roller bearings, we have it that “for heavy weights it would seem that a greater rolling surface must be obtained before we can have a successful bearing, and yet, combined with this greater rolling surface, there must be a purely rolling action to eliminate the wear that results from rubbing and crystallization.”

As stated by a noted authority, the peculiar advantage of the roller bearing lies in the fact that in the ideal conditions there is no relative sliding, and, therefore, theoretically, no friction. As also stated by him, however, there are several difficulties in the way of obtaining the theoretically perfect conditions in practical operation. These are: (1) the concentration of the load upon points; (2) the almost insurmountable difficulty of obtaining truly circular cylindrical rollers; (3) the friction on the surfaces of the rollers themselves; (4) the difficulty of adjustment; (5) the lack of parallelism when the rollers are slightly worn; (6) the difficulty of providing for end thrusts or side pressures; (7) the blows and shocks resulting when wearing has occurred on the surfaces of the rollers. He further explains that to any extent whatever, however small, that the surface of contact deviates from the theoretical or geometrical line, the action between the two surfaces deviates from the theoretically perfect rolling contact, involving sliding or frictional contact proportionate to the deformation of the roller. The principal cause for the breaking of roller bearings, which is so fertile a source of annoyance and disablement to the road wheels of motor carriages, is due to the hammering action resulting when any single roller lacks in the point of uniformity of hardening with its mates, which results in a greater initial strain in its material.

Constructional Points on Roller Bearings—Given the best possible process available to the practical machinist for the needs of adequately shaping and hardening rollers, the problem of the best construction becomes almost entirely one of proper assembling of the several parts. As shown by the accompanying illustration, the usual method of mounting roller bearings is to enclose them in a suitable case, in which the several cylindrical rollers are separated, so that, rotating on their own axes, their surfaces do not come into contact. It is a very usual practice to include end thrust ball bearings at the extremities of the roller cylinders, so as to still further reduce the wear and friction incident on the rotation of the several cylinders.

One of the most excellent types of roller bearing for motor carriages is the "American" roller bearing, which, as shown by



FIG. 468.—Roller Bearings Enclosed in a Retaining Cage. The bearings are hung to the two end pieces of the cage, being separated by stationary pieces of metal. The inner tube is the rotating axle; the outer, the axle box.

the accompanying illustrations, consists of a set of main rollers intended directly to sustain the weight, and running in races on the hub and on the axle. These main rollers are separated and guided by intermediate separating rollers, whose office is solely that of separating and guiding. These separating rollers are confined between the centres of the main rollers and overlap their ends, their action being entirely rolling. The supports of these separating rollers are had in three rings held in place by the flange ends of the separators and running in narrow beveled grooves in the separators and in the fixed caps which enclose the entire mechanism. The rolling parts are so arranged that the separators engage their supports in perfect harmony with the main rollers, traveling just fast enough to keep up with them in going about the axle, thus avoiding both dragging and pushing.

In this type of bearing the end thrust is entirely taken by bevels, on the principle of the flanges on car wheels, this construction involving that there is no rubbing friction; the action between the ends of the roller and bevels, being purely a rolling one, they are thrust against each other. As claimed by the manu-

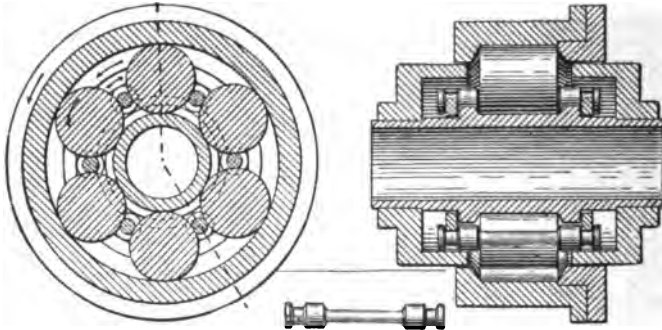

FIG. 463.—Sectional Diagrams of the "American" Roller Bearing. These bearings are beveled at the ends, as indicated, the bevels taking up the end thrusts, and are separated by smaller rollers, one of which is shown below the larger figures. These separating rollers do not come into contact with the rotating axle.

facturers, the separators hold the main rollers far better than any cage could, while the wear upon them is practically negligible, the result being that the main rollers are never allowed to twist around, as is frequently the case in caged bearings.

CHAPTER FORTY-THREE.

ON THE NATURE AND USE OF LUBRICANTS.

Of Lubricants for Various Purposes.—One of the most important considerations in connection with the operation of a motor vehicle, of any power, relates to the proper lubrication of the moving parts. As is perfectly evident on reflection, it is necessary that all such parts should be supplied with oil or lubricating grease, but it is also a fact, not so well understood, that different kinds of lubricant are necessary to the different kinds of mechanisms.

Of Lubricants for Gasoline Engine Cylinders.—Every reliable dealer in lubricants has a specially prepared grade of oil for a gas engine cylinder, and still another for use in the cylinder of a steam engine, and all agree to the statement, that the kind of lubricant suitable in one case is wholly useless in the other. The primary reason for this distinction is that, as we have seen, the cylinder of a gas engine operates under a far higher temperature than is possible even in a steam engine, and consequently the oils intended for use in the former case must be of such a quality that the point at which they will burn and carbonize from heat is as high as possible. Furthermore, it is essential in a gas engine cylinder that the oil should be constantly supplied, and for the purpose of properly meeting this requirement a number of different kinds of dripping and filtering oil cups have been devised and put into practical use.

Requirements in Gas Engine Lubricants.—As has been repeatedly pointed out by gas engine authorities, the apparently long period spent in finally perfecting the motor was due almost entirely to the fact that the subject of proper lubrication was not fully understood. With the ordinary oils, which are sufficiently suitable for use in the steam engine cylinder, it was impossible to obtain anything like a satisfactory speed and power efficiency, and only when the superior properties of mineral oils were better understood was the present high degree of perfection in any

sense obtainable. Even to the present day the question of proper lubricants for gas engines is most essential, and, as has been pertinently remarked, "the saving of a few cents per gallon in purchasing a cheaper grade of oil for this purpose is the most expensive kind of economy imaginable." The general qualities essential in a lubricating oil for use on gas engine cylinders include a "flashing point of not less than 360° , Fahrenheit, and fire test of at least 420° , together with a specific gravity of 25.8 and a viscosity of 175."



FIG. 464.



FIG. 465.



FIG. 466.

FIGS. 464, 465, and 466.—Three Forms of Adjustable Oil Feeding Cup. In the first and second figures, the flow of oil is regulated by the thumb screw at the top. This allows the oil to drip at any required rate. The first figure shows a "sight-feed oil cup," which, as shown, means that the rate and constancy of the feed may be seen through the section of glass tube at the base. In the third figure, the hand-wheel at the top is merely for filling the reservoir, the amount of flow being regulated by the cocks at the base. By regulating the flow by the right-hand cock, the left-hand acts only to open and close the vent, permitting a flow of no more and no less than that determined by the right-hand cock. All three forms are used on automobiles, although the first two are the most common. The first is used for cylinder lubrication.

Some Objections to Organic Oils.—While a number of animal and vegetable oils have a flashing point, and yield a fire test sufficiently high to come within the figures specified, they all contain acids or other substances which have a harmful effect on the metal surfaces it is intended to lubricate. In addition to this, their tendency to gum or congeal under certain conditions of temperature or pressure render them unfit for the purpose of gas engine lubrication.

The Use of Graphite as a Lubricant.—Many authorities strongly recommend the use of powdered or flaked graphite in the cylinders of explosive engines for the reason that this substance is one of the most efficient of solid lubricants, especially at high temperatures. It has been found especially useful in some steam engine cylinders and in general on the bearings and moving parts liable to become overheated. According to several well-known authorities, it is well adapted for use under both light and heavy pressures when mixed with certain oils. It is also especially valuable in preventing abrasion and cutting under heavy loads and at low velocities.

In using graphite as a lubricant, it is positively essential to remember one thing: It is, as said, very useful *for certain purposes*, when mixed with some liquid oil lubricants. However, it is impossible to use it in connection with oils that are to be filtered through the small orifices of constant feed oil cups, as on the cylinders and bearings of engines. The reason for this is that it will not flow through small holes, even when mixed with very thin oil; and the very cooling of a bearing will cause the graphite, mixed with oil, to clog up the oil hole to an extent that may not be remedied by the reheating of the bearing, after the stoppage of the lubricant. On the same account, it is essential that the diameter of the oil conduit to any moving part be ascertained to be of suitable shape and proportions before the use of any solid lubricant is attempted.

The Tests and Qualities of Lubricating Oils.—It is perfectly possible to use an oil having a fire test at the point already mentioned in a gas engine cylinder whose temperature at explosion is nearly four times greater, because with a properly adjusted water circulation the burning and carbonization of the oil is constantly prevented. The heat-absorbing action of the jacket water is also efficient in retaining at the required point the viscosity of the oil—which is to say, the quality of dripping at a certain ascertained rate through a narrow aperture under pressure. This quality virtually refers to the thinness of the oil. A well-known manufacturer of lubricating oils for gas engine cylinders well states the ideal qualities to be sought, as follows: "There is no danger of this oil burning or smoking in the cylinder and thus causing a carbonaceous deposit, which so seriously

interferes with the proper running of the engine. We have repeatedly known of this oil, when put into a cylinder which had not been properly cleaned, cutting out the carbonaceous matter that had accumulated from the use of an inferior oil, after which the cylinder would remain clean and polished by the action of the oil alone." Combined with these ideal elements, the claim is made that this particular variety of oil has a very low "cold test," with the very necessary insurance against congealing, and consequent delay and inconvenience in starting the engine. Its resistance to heat is also placed at such a figure that it will not become unusually thin as will some qualities of oil, the reason being that its viscosity is maintained at the desired point.

In choosing lubricants for any of the moving parts of a self-propelled road vehicle it is especially essential to see that the quality of resisting temperatures, both high and low, without change of useful consistency, should be present. An oil that will congeal at ordinary low temperatures, or become thin at ordinary high temperatures, is, of course, entirely unsuitable for this purpose. Furthermore, the quality of flowing freely from well-adjusted oil cups should be assured, since the high speed of automobile engines engendering a constant vibration, affecting more or less the adjustment, involves that the oil supplied should be a subject of constant solicitude. To state the matter in a few words, all competent authorities seem to agree that the conditions of automobile operation require the use of mineral oils on all moving parts and the avoidance of any mixture with animal or vegetable oils, which, although frequently used in stationary engines, cannot but result in inconvenience, not to say disaster, in automobile practice.

Since most manufacturers of motors and vehicles furnish moderately full directions for dealing with the question of lubrication, many of them offering for sale brands of oil which have been carefully tested by themselves, it will be hardly necessary to add more to the principles already laid down. If the automobile driver constantly bears in mind the fact that an oil suitable for one portion of his machinery is not of necessity suitable for every other, and will observe the conditions essential to maintaining the oil used at its proper consistency, he will have little trouble upon this score.

CHAPTER FORTY-FOUR.

HINTS ON STEAM VEHICLE OPERATION.

Filling the Boiler of a Steam Carriage.—The first essential operation in starting the steam carriage is to fill the fuel and water tank, which act must be accomplished by hand in the absence of boiler steam to do the work automatically. The water tank may be filled either by means of flexible pails, such as is shown in Fig. 189, or else by an ordinary hose. The boiler may be filled in either one of two ways: An ordinary garden hose may be coupled to the blow-off valve and water injected until, as shown by the water glass, the desired level has been reached—this level is usually about two-thirds up the glass—or, under certain conditions, it is possible to fill the boiler from the tank before the steam has been produced, by jacking up the rear wheels and allowing water to syphon in by causing the pump valves to operate automatically. This is obviously the least convenient way of accomplishing the result, and would hardly be attempted in any carriage equipped with an auxiliary hand-pump. The owner of a steam carriage will speedily find the most convenient method of filling his boiler, since it is a practice which must be performed daily, on account of the necessity of blowing off the boiler after each day's work, in order to prevent the accumulation of incrustations and the corrosion due to the harmful chemicals held in solution in the water. As cannot be too strongly emphasized, there is no greater source of injury to a boiler than allowing the water to stand in it for any unnecessary period after the fire is extinguished. The numerous corrosive substances held in solution speedily eat out and destroy the boiler metal, while the crust-forming sediments produce scale deposits impervious to heat, which eventually cause overheating of the metal and burning out, with all its attendant dangers and inconveniences.

Blowing Off the Boiler.—The operation of "blowing off" the boiler is a simple one, but certain conditions must always be observed.

In the first place, the valve controlling the fuel supply to the burner should be shut off, thus extinguishing the fire.

Second, the blow-off valve, situated at the base of the boiler, and opened and closed by a cock, should be opened, allowing the water to be ejected under pressure of the steam.

Third, the valve leading from the water tank should be closed, thus shutting off further supply.

Fourth, the drip cocks should be opened, allowing the residue of moisture to escape, and the boiler allowed to cool and dry.

Fifth, no cold water, either for feed or for cleaning, should be introduced into the boiler until it is perfectly cool. Not to observe this rule involves cracking or uneven contraction of plates or tubes and may cause leaking.

In preparing to start the carriage again, feed water is either injected into the blow-off valve through a hose, or fed into it with the auxiliary hand pump, such as is provided in most up-to-date steam carriages.

Filling the Gasoline Tank: Quality of Gasoline.—The next essential act in preparing a carriage for running is to fill the gasoline tank. This operation must be preceded by closing all valves leading to the burner. The gasoline is poured into the tank through a funnel after the cover cap has been removed. The tank should never be filled higher than a level between two and three inches below the top, in order to allow space for air pressure, which is used to force the gasoline into the tubes leading to the burner. After the tank has been filled to the proper height, the cap should be screwed tightly upon its nipple in order to prevent the escape of the compressed air, or the evaporation of gasoline. The only precaution necessary to observe in filling the fuel tank is to avoid smoking, or the proximity of any fire, for although gasoline is safer than kerosene, from the fact that it will not explode in a closed vessel, it is many times more inflammable, and if once ignited will burn so fiercely that great damage may be done before the flame can be extinguished. The quality of gasoline most generally employed for the burners of steam carriages has a specific gravity of 76° , and is known to the trade as "stove gasoline." There are numerous forms of petroleum spirit, known, respectively, as gasoline, naphtha, benzine and benzolene, and the like, but these differ among themselves prin-

cipally in point of specific gravity. It is particularly desirable to avoid the use of any sort of deodorized naphtha spirit, such as is sold under various names for many different purposes, such as cleaning clothes, since the deodorization is effected by the use of chemical substances, which will prove harmful in clogging the needle valve and burner openings. Any kind of pure mineral spirit, known as naphtha, gasoline, benzine, etc., is perfectly suitable for use in a carriage burner, but those having specific gravities much below 74° or 76° require considerably more heat to vaporize them, and hence represent a lower percentage of efficiency.

Starting and Running the Engine.—In starting the engine, it is desirable to observe several conditions. After the steam has reached 100 pounds pressure, as shown by the gauge, it should be slowly admitted to the cylinder, in order to allow the parts to become thoroughly warmed before opening the valves full. Many steam carriage engine cylinders are equipped with automatic relief cocks, which eject the condensed steam formed in the cylinders at this time; others have hand cocks attached to the cylinders for the purpose of draining off any condensation in the same way. It is exceedingly essential that there should be no water in the cylinders, but since most steam carriage engines are equipped with drain cocks, automatic or otherwise, it is not necessary to worry about this condition, or to attempt to remedy it, unless special and explicit directions are furnished by competent authorities on the particular engine in use. The presence of water in the cylinder may be recognized by the familiar clicking, or pounding, produced in running the engine.

As already stated, it is particularly necessary to observe the water level in the boiler, as shown by the water glass. To facilitate this, small mirrors are placed on the inside of the dashboard of most steam carriages so that the driver may constantly inform himself on this point. In order to judge whether the glass is recording correctly or not, the driver may either test by the try-cocks, or judge of the work done by the engine on a level road, as compared with the work it should do with the steam pressure recorded in the gauge. The water level will, of course, sink below the normal point in ascending a steep hill, on account of the unusual draft of steam required. The engine will

also operate at slower speed, according to the grade. But if the speed at full steam falls very much on the level, with a good road surface, it is evident that too much or too little water is being fed to the boiler, either condition involving dangers already explained. When the water is at too low a level, the pressure recorded in the gauge will be altogether higher than that required to operate the engine under usual conditions. As shown in a table on page 271, the pressure of steam invariably corresponds to a definite temperature. Consequently, when the temperature has risen above a safe point, it is very certain that the boiler is overheated. This fact may be readily verified by testing with the try-cocks, and when proved, the auxiliary hand-pump should be operated or the by-pass valve closed, if the latter has been opened.

Causes of Lost Efficiency.—Among other causes of inefficiency in a steam engine, such as occur under ordinary conditions, we may mention the wearing of the valves and of the piston rod packing. The wearing of the valves will, of course, tend to very great waste of steam, and will eventually render the engine inoperative. It is necessary to employ the services of a skilled machinist to remedy any trouble with the valves, since it is a delicate and complicated matter, which cannot be treated in mere descriptions and directions. One of the most familiar symptoms of valve trouble is pounding in the cylinder. The fibre packing in the stuffing boxes is frequently liable to be worn and rendered useless by the constant friction of the piston rod working at high speed. Such packing is formed of specially prepared vegetable fibre, generally mixed with some graphite preparation, and may be readily renewed after a little practice and observation. Contrary to the opinions of many persons, asbestos is a very inappropriate substance for the packing of a stuffing box, since the steam and condensed water have a tendency to cut and finally destroy this substance.

A leaky stuffing box—which is to say, one that allows steam to escape from the cylinder—is caused by wearing down of the fibre packing. The difficulty may be overcome in some cases by simply tightening the nut, or screws, holding the gland in place. In doing this care should be taken that the pressure is no greater than is just sufficient to prevent leaking. In some cases, the

inner surface of the packing wad has become charred by the action of the steam, in which case it may be simply turned over, putting what was the inner face against the gland, so as to give a fresh surface to the steam. When new packing is inserted, or old packing turned, the inside of the stuffing box should be wiped dry and thoroughly oiled.

Economizing Steam by Varying the Cut-Off.—The driver of a steam carriage very soon acquires the idea that it is both possible and desirable to economize steam in certain cases by manipulation of the throttle valve or reverse lever. While this matter has already been discussed at some length, it may be in place to remark here that it is possible with the observance of the principles previously laid down to vary the quantity of the steam used, and also the events in the engine cycle, by a proper handling of the reverse lever. By moving the lever from the position of full gear toward mid-gear, the lead of the valve, and, consequently, the point of cut-off, may be varied so as to shorten it from, say, the normal position of three-quarters or seven-eighths stroke to one-quarter or even less. This hastening of the cut-off is, of course, accompanied by a consequent loss of available energy, and can be practically employed only on the best roadways. Several practical steam carriage drivers, who have experimented extensively with this method of varying the steam inlet, have expressed the opinion that a cut-off at one-half stroke is the practical limit for a light carriage engine. In ascending hills, of course, the full power of the steam must be used as near as possible throughout the stroke, or else the carriage will be unable to make the grade at anything like a reasonable speed.

Points on Pump Operation and Water Supply.—Among the numerous other causes of ineffective operation may be mentioned the failure of the pump to supply sufficient water to the boiler and failure of the burner to supply sufficient heat to keep up steam. Where an auxiliary steam pump is employed, between the tank and the boiler, the deficiency of the regular pump may be readily compensated. When no such pumps are employed, it is, of course, impracticable to maintain the proper supply. It is then necessary to inquire into the cause of inactivity in the plunger-pump.

(1) The cock between the water tank and pump may be closed, or clogged.

(2) The strainer at the water tank may be clogged with impurities.

(3) The packing of the plunger may be loosened.

(4) The pump may be air-bound. In this case the by-pass valve should be opened, allowing the air to escape into the water tank. When this is accomplished, it should be again closed, and the pump will be found to work without trouble.

(5) The check valves may be clogged with impurities and need cleaning, in which case they may be readily removed—the cock to the tank having first been closed—and any sediment or impurities cleaned out.

There are several other possible causes of ineffective operation of the plunger-pump, due to lost motion and other mechanical troubles, which a skilled engineer can readily detect by jacking up the rear wheels of the wagon and observing the pump in operation.

Troubles with the Burner.—The most familiar cause of insufficient heating of the burner is low air pressure in the gasoline tank. This may be readily remedied by operating the air pump until the air pressure gauge shows the normal 35 to 50 pounds. If the trouble is not due to this cause, it probably results from impurities in the atomizing nozzle leading into the mixing tube of the burner, or to sediment collected in the gauze screens placed in the supply pipes between the gasoline tank and the regulator. The atomizing nozzle may be readily cleaned with a piece of fine wire. The gauze screens must be removed from their designated positions in the tubes and suitably cleaned or new ones substituted in their place. With the use of a good quality of gasoline, and the maintenance of the necessary air pressure, there is no particular reason for either clogging of the nozzle or of the gauze screens.

In case of burning back in the burner, the fire should be immediately extinguished by closing the gasoline supply valve and waiting several minutes before relighting, in order that the gas within the burner may have been thoroughly exhausted. Burning back is generally caused by an excessive down-draft on the burner.

CHAPTER FORTY-FIVE.

HINTS ON THE CARE AND OPERATION OF A GASOLINE VEHICLE.

Water and Gasoline Supply.—The first consideration previous to starting a motor carriage is to see that the water and gasoline tanks are properly filled; indeed, it is a good practice to make it a habit to test both tanks on each occasion of preparing for a run. Some motor carriages have glass gauge tubes fixed to the fuel and water tanks, somewhat after the manner of the water glasses used on steam boilers, so that the level of the liquids in both cases may be determined at a glance. In others, where this convenience is not included, it is a simple matter to test the level by inserting a stick in the filling hole and noting the height to which the liquid rises on it. This may be done with gasoline, as well as with water, if the stick is withdrawn quickly from the liquid and examined before evaporation takes place.

Lubrication.—The first important consideration involved in preparing a carriage for a run is to see that the moving parts are properly lubricated. Every carriage or motor is sold with directions for providing for this necessity, the rate of oil consumption and the quantity being specifically designated. The principal parts which it is particularly necessary to keep thoroughly oiled are the cylinder pistons, the bearings of the crank shafts and fly-wheels, the differential gear drum and the change speed gearing.

Since on most well-built motors and carriages the moving parts are supplied with lubricating oil by means of sight feed oil cups, of familiar design, it is necessary to do no more than to see that the required level of oil is always maintained. As specified by many motor carriage authorities, it is desirable to thoroughly examine and replenish the oil supply in the adjustable feed cups at the end of about every thirty miles of run. Another consideration of importance in this particular is that before replenishing the supply of oil to such parts as the crank case

or the differential gear, the old lubricant should be thoroughly evacuated by means of the vent cocks supplied in each case. The reason for this is that, after a run of from twenty to thirty miles, the oil in the moving parts is apt to be largely contaminated with dust and other impurities, which tend to interfere with its usefulness as a lubricant.

General Directions for Starting the Motor.—When all reasonable preparations have been made, and it is evident that the motor and running parts are in working order, the next important step is to open the cock leading from the gasoline tank to the carburetter, and also to close the sparking circuit by means of the designated switch, or plug, provided for that purpose. The method of starting is by turning a handle on the crank shaft, as already mentioned, until the engine has taken up its cycle and proceeds to run by the force of the explosions produced within the cylinder. As a usual thing, it is necessary to turn the crank through no more than two complete revolutions; but if the motor fails to operate at that point, and cannot be readily started, the fault usually lies either in a defective fuel mixture or else in some derangement of the sparking circuit. As a matter of fact, the former course, particularly when the fuel mixture is too rich, is liable to interfere with the sparking apparatus, by short-circuiting the plug. In many motors, however, the difficulty may be remedied by squirting a small amount of gasoline through the compression tap, after which the motor will probably operate without trouble.

Failure of the Motor to Operate.—In a large number of cases when the motor fails to start, or stops or slows down from no other assignable cause, it is probable that the trouble lies in some disarrangement of the electrical sparking circuit or attachments. If a jump-spark is used, it is probable that the plug has become short-circuited through either a deposit of carbonized particles between the sparking points, which defect frequently follows the use of too rich a fuel mixture, or else that the insulation has been broken down and that a path is provided for the electrical current between the two conducting portions of the plug. If the former defect has occurred, the sparking plug may be unscrewed from the combustion chamber and the condition

may be readily detected. This carbon deposit may be readily removed by rubbing the points with a piece of light emery paper until the bright surface of the metal is again visible. Care should be taken, however, by non-practiced hands, lest the metal be unduly worn in the operation. The sparking points of a jump-spark plug should always be mounted at a fixed distance of not more than one twenty-fifth of an inch, which is approximately equal to the thickness of an average heavy business card. If, on the other hand, the plug has become disabled by a short-circuit through the body below the sparking points, it is practically useless, and it is unnecessary for the driver to attempt to repair the injury. The reason of this is that such a condition of short-circuiting is due to the fact that the insulation has been burned out, or that foreign substances have been deposited in such a manner as to leave a path for the electrical current.

Failure of the engine to operate properly may be readily traced to the sparking circuit by unscrewing the tap of the peep-hole, or the disconnecting inlet valve case, according to the kind of motor that is used, and observing the intensity and quality of the spark, if any occurs, by continuing to turn the crank used for starting the motor.

Troubles with the Ignition Circuit.—Troubles with the ignition circuit, however, may be due to derangements at some point other than the sparking plug, and before removing the plug and substituting a new one it is desirable to see that all the other parts of the circuit are in proper working condition. Among other things that should be carefully provided for, the driver should see that: (1) Insulation of the lead wires is perfect at all points and that short-circuiting does not occur through contact with any of the metal parts of the vehicle or motor; (2) the terminals of all lead wires should be tightly screwed under binding post; (3) the contact-breaking trembler should be adjusted so as to operate properly, which means that all screws and attachments should be kept securely tight; (4) the battery should be tested occasionally in order to ascertain whether it is giving the full amount of current. Most of the chemical batteries used in the sparking gas engines may be relied upon to give the required current for a certain definite period; therefore, unless some defect in circuit has caused unusual waste of electrical energy, or

an unusually long continued operation of the vehicle has practically exhausted it for the time being, it is safe to conclude that the trouble is at some other point. A battery may be easily tested by the use of the ordinary pocket gauge, which may be obtained from any electrical supply house, and when it is desired to make a test the gauge may be readily connected to the terminals of the battery and will register the output with sufficient accuracy for all practical purposes. In making such a test, however, it is desirable to continue it no longer than is absolutely necessary to read the gauge record, since the operation means a short-circuiting of the battery, which will prove fatal to any chemical cell if long continued. Where chemical cells are used, it is a comparatively simple matter to carry several extra cells in the vehicle in order to be able to make substitution in case of suspected difficulty with the battery.

Starting the Carriage.—When the motor is running properly and the driver wishes to start the carriage, the first operation is to throw on the clutch with the speed adjusted to low gear; this is very essential in order that the start should not be too sudden, which would result in discomfort to the occupants of the carriage and strain on the parts. After the carriage has once fairly started, the second speed may be thrown in as soon as desired. It is very essential, however, particularly for an unskilled driver, to recognize the fact that with any variety of change speed gearing, the changing of speed ratios must always be preceded by throwing out the main clutch. In changing from a lower to a higher speed, it is important that the operation should be performed on as level a roadway as possible and should be consummated before the carriage has lost its momentum. On the other hand, in changing from a high speed to a lower one, it is exceedingly desirable, if not imperative, that the momentum of the carriage should be allowed to fall as near as possible to the desired speed before the new gear is thrown in. Hill-climbing is invariably performed with a low gear, but it is well to observe the rule that the higher speed should be used until the travel of the carriage has fallen considerably, and the motor shows signs of laboring; it is then the time to throw in the low speed, which relieves the motor of any undue strain, and enables the hill to be climbed without injury to the moving parts.

Working the Carriage on Down Grades.—In descending grades many drivers indulge in the sport of coasting, which is very delightful, but somewhat dangerous with heavy-weight cars, and an inexperienced driver should be particularly careful in performing this feat, since it has frequently happened that a heavy car has become unmanageable on a steep grade, the steering apparatus failing to act, with the result that a serious accident occurs. In coasting the clutch is thrown out and the carriage allowed to move down the grade under its own momentum. With a large majority of gasoline carriages, however, as already noted in connection with the De Dion, it is possible, if not desirable, to leave the motor in gear with the driving connections and by interrupting the sparking circuit, allow it to act as a buffing brake to maintain the speed within safe limits. In coasting down a hill a driver should always observe the precaution of keeping his foot or hand, as the case may be, on the connections of the braking lever, in order that the speed of the carriage may be checked at any desired point. It is always well to keep the hand on the braking connections in any such position, until sufficient experience in running the carriage has been obtained to enable risks to be incurred with impunity.

In descending a very steep grade the operator should never allow his vehicle to attain a high speed. If the motor is left in gear with the sparking circuit interrupted, as already mentioned, the low gear of the speed changer should be used, but the retarding effect of the piston compression should be assisted by slight pressure upon the emergency brakes. If the brakes fail to work properly, in order to restrain the speed before it reaches an unmanageable point, the high gear should be thrown in, which will materially assist the effort of the brakes, unless the latter are completely disabled.

Turning Corners and Side Slipping.—There are several other conditions met with in ordinary travel which should be rigidly observed. The first of these relates to the necessary operations performed in turning corners. Any turns, except those of the longest radius, should be made on low gear. If a sudden turn is to be made, as in rounding a street corner, the best practice, when moving at a high speed straight ahead, is either to throw out the main clutch and allow the vehicle to turn with its

own momentum, or to retard the spark by means of the properly designated connections to hand, in order that the carriage may not race around the corner, with the very probable result of incurring injury or accident, particularly on a wet or greasy street, where the wheels are liable to slip sideways, when turning at the high speed, with the result in frequent instances of seriously damaging the running gear. Also, if too short a turn is made, the carriage will have a tendency to swing bodily, and may even go so far as to turn completely around in an opposite direction. This will not, however, cause a well-built vehicle to capsize, owing to the properly adjusted centre of gravity, but, particularly with heavy cars, it is exceedingly liable to break an axle or rend a tire. Should this accident occur under these conditions, the main clutch should be immediately thrown out, and the steering wheels held strongly in the direction in which it is desired to travel. On no account should the brakes be applied except as a last resort. Even then, it is a questionable procedure, and one liable to disarrange the steering, rather than check the undesired motion.

Common Causes of Failure to Operate.—In addition to the causes already enumerated for the failure of the motor to start or run properly, we may mention several other conditions which will produce the same result. These are: (1) an imperfect combustion, owing to a bad fuel mixture; (2) imperfect compression, owing to leaks in the cylinder or to defective valves; (3) dirt or water in the carburetter.

Troubles with the Sparking Apparatus.—In case the driver suspects that the failure of the motor to operate is due to some trouble with the sparking apparatus, producing imperfect combustion, he may readily verify his suspicions by advancing the spark. As stated by a well-known authority on motor vehicle operation: "If the motor does not miss with the spark advanced, you may rest assured that the trembler needs adjustment; if, on the other hand, varying the position of the spark lever does not alter the condition of things, then there must be either a wire loose, or the gasoline mixture must be at fault. To adjust the mixture move the gas lever back and forth. If the engine sticks, it means, you may rest assured, that there is a wire loose or a

short-circuit somewhere. Go over the wiring carefully and see that the same is properly fastened to the sparking plug and to the battery terminals. If the trouble still continues, there must be a short-circuit." This short-circuiting is probably due to breaking down of the insulation in the sparking plug or to a collection of carbonaceous material between the sparking points.

Troubles Due to Breakage or Wear.—In case the motor suddenly ceases to run, there are three common causes to which the trouble may be attributed: (1) Breakage of the exhaust valve; (2) sticking or breaking of the inlet valve; (3) short-circuiting of the sparking plug. The trouble due to either of the first two of these causes may be readily discovered by turning the starting handle, and finding no resistance or compression, such as should normally be encountered.

In case the exhaust valve should be found broken, it is necessary to insert a new valve in the seat, being careful to see that all reciprocating parts are properly adjusted and of the right length to interact. The sticking of the inlet valve may be caused by excessive heat or a catching of the spring, although either of these troubles is rare. If the valve or its spindle be broken, the only thing to be done is to replace it.

Causes of Imperfect Combustion.—There are several causes to which imperfect combustion may be attributed: (1) the valve may be pitted or clogged; (2) a leak may have occurred around the thread of the sparking plug; (3) a compression tap may be loose or leaking; (4) the piston rings may be clogged or stuffed; (5) the piston rings may work around, so that the spaces between their ends get in line; (6) the gasket of the sparking plug may be broken; (7) the inlet valve spring may be too weak, which fault accounts for an occasional popping noise in the carburetter.

The first difficulty may be overcome by grinding the valve, which, however, is an operation just as well left to skilled machinists.

Any leak that may be discovered around the thread of the sparking plug may be readily remedied by screwing the plug home. Troubles with the piston rings may be remedied by removing the piston from the cylinder occasionally and thoroughly cleaning it. Where the rings are found to work around the cylin-

der, the piston must be taken out and the rings placed in their proper relative positions. Any trouble with the spring of the inlet valve may be remedied by substituting a new spring.

The matter of dirt or water in the carburetter is a serious one in motor vehicle management. Water in the carburetter necessarily results from vaporizing of the gasoline. Since this liquid always contains certain portions of water, it is necessary to periodically drain the carburetter and remove it, as well as any other waste materials that may happen to be present.

Non-Freezing Water Jacket Solutions —According to popular opinion, largely borne out in practice, it is difficult to operate a gasoline vehicle in winter time, owing to the freezing of the jacket water, or to excessive cooling of the cylinder. In this belief several manufacturers of vehicles propelled by air-cooled motors advertise their respective products as "The only serviceable winter vehicle." While it is undoubtedly difficult to obtain good results from a gasoline vehicle in attempting to start in cold weather, it is possible to largely neutralize the difficulties due to the freezing of the jacket water by mixing certain chemicals in the water. As already stated, various authorities recommend a solution of equal parts, by weight, of water and glycerine; others, a saturated solution of chemically pure calcium chloride mixed with equal parts of water, by measure. As already stated on page 369, any motorist attempting to use the latter solution should carefully avoid substituting the so-called chloride of lime for the desired calcium chloride. Another solution, which is recommended by other authorities, should consist of a mixture of water and glycerine, the latter being about 30 per cent. of the former by weight, and adding to this mixture two parts, by weight, of carbonate of soda. This liquid should be entirely drawn off and removed once a month.

Another trouble encountered in running a gasoline vehicle in cold weather is the difficulty of properly vaporizing the fuel. This condition may be largely neutralized by properly heating the carburetter in the manner provided, as we have seen in a number of typical instances. At all times heating materially assists the process of vaporizing.

PROPERTIES OF SATURATED STEAM.

Absolute pressure per sq. in.	Temperat're in degrees.	Heat units, from zero, per lb.	Latent heat in degrees.	Density or weight of one cubic ft.
Lbs.	Fahr.	Fahr.	Lbs.
1	102.1	1145	1042.9	.0030
2	126.3	1152.5	1025.8	.0058
3	141.6	1157.1	1015	.0085
4	153.1	1160.6	1006.8	.0112
5	162.3	1163.4	1000.3	.0138
6	170.2	1165.8	994.7	.0163
7	176.9	1167.9	990	.0189
8	182.9	1169.7	985.7	.0214
9	188.3	1171.4	981.9	.0239
10	193.3	1172.9	978.4	.0264
11	197.8	1174.2	975.2	.0289
12	202	1175.5	972.2	.0314
13	205.9	1176.7	969.4	.0338
14	209.6	1177.9	966.8	.0362
14.7	212	1178.6	965.2	.0380
15	213.1	1178.9	964.3	.0387
16	216.3	1179.9	962.1	.0411
17	219.6	1180.9	959.8	.0435
18	222.4	1181.8	957.7	.0459
19	225.3	1182.6	955.7	.0483
20	228	1183.5	952.8	.0507
21	230.6	1184.2	951.3	.0531
22	233.1	1185	949.9	.0555
23	235.5	1185.7	948.5	.0580
24	237.8	1186.5	946.9	.0601
25	240.1	1187.1	945.3	.0625
26	242.3	1187.8	943.7	.0650
27	244.4	1188.5	942.2	.0673
28	246.4	1189	940.8	.0696
29	248.4	1189.7	939.4	.0719
30	250.4	1190.3	937.9	.0743
31	252.2	1190.8	936.7	.0766
32	254.1	1191.4	935.3	.0789
33	255.9	1191.9	934	.0812
34	257.6	1192.5	932.8	.0835
35	259.3	1193	931.6	.0858
36	260.9	1193.5	930.5	.0881
37	262.6	1194	929.3	.0905
38	264.2	1194.5	928.2	.0929
39	265.8	1195	927.1	.0952
40	267.3	1195.4	926	.0974
41	268.7	1195.9	924.9	.0996
42	270.2	1196.3	923.9	.1020
43	271.6	1196.7	922.9	.1042
44	273	1197.2	921.9	.1065
45	274.4	1197.6	920.9	.1089
46	275.8	1198	919.9	.1111

PROPERTIES OF SATURATED STEAM (*continued*).

Absolute pressure per sq. in.	Temperat're in degrees.	Heat units from zero, per lb.	Latent heat. in degrees.	Density or weight of one cubic ft.
Lbs.	Fahr.	Fahr.	Lbs.
47	277.1	1198.4	919	.1133
48	278.4	1198.8	918.1	.1156
49	279.7	1199.2	917.2	.1179
50	281	1199.6	916.3	.1202
51	282.3	1200	915.4	.1224
52	283.5	1200.4	914.5	.1246
53	284.7	1200.7	913.6	.1269
54	285.9	1201.1	912.8	.1291
55	287.1	1201.4	912	.1314
56	288.2	1201.8	911.2	.1336
57	289.3	1202.1	910.4	.1364
58	290.4	1202.5	909.6	.1380
59	291.6	1202.8	908.8	.1403
60	292.7	1203.2	908	.1425
61	293.8	1203.5	907.2	.1447
62	294.8	1203.8	906.4	.1469
63	295.9	1204.1	905.6	.1493
64	296.9	1204.5	904.9	.1516
65	298	1204.8	904.2	.1538
66	299	1205.1	903.5	.1550
67	300	1205.4	902.8	.1583
68	300.9	1205.7	902.1	.1605
69	301.9	1206	901.4	.1627
70	302.9	1206.3	900.8	.1648
71	303.9	1206.6	900.3	.1670
72	304.8	1206.9	899.6	.1692
73	305.7	1207.1	898.9	.1714
74	306.6	1207.4	898.2	.1736
75	307.5	1207.7	897.5	.1759
76	308.4	1208	896.8	.1782
77	309.3	1208.2	896.1	.1804
78	310.2	1208.5	895.5	.1826
79	311.1	1208.8	894.9	.1848
80	312	1209	894.3	.1869
81	312.8	1209.3	893.7	.1891
82	313.6	1209.6	893.1	.1913
83	314.5	1209.8	892.5	.1935
84	315.3	1210	892	.1957
85	316.1	1210.3	891.4	.1980
86	316.9	1210.6	890.8	.2002
87	317.8	1210.8	890.2	.2024
88	318.6	1211	889.6	.2044
89	319.4	1211.3	889	.2067
90	320.2	1211.6	888.5	.2089
91	321	1211.8	887.9	.2111
92	321.7	1212	887.3	.2133
93	322.5	1212.3	886.8	.2155

PROPERTIES OF SATURATED STEAM (*continued*).

Absolute pressure per sq. in.	Temperat're in degrees.	Heat units, from zero, per lb.	Latent heat in degrees.	Density or weight of one cubic ft.
Lbs.	Fahr.	Fahr.	Lbs.
94	323.3	1212.5	886.3	.2176
95	324.1	1212.7	885.8	.2198
96	324.8	1213	885.2	.2219
97	325.6	1213.2	884.6	.2241
98	326.3	1213.4	884.1	.2263
99	327.1	1213.6	883.6	.2285
100	327.9	1213.8	883.1	.2307
101	328.5	1214	882.6	.2329
102	329.1	1214.3	882.1	.2351
103	329.9	1214.5	881.6	.2373
104	330.6	1214.7	881.1	.2393
105	331.3	1214.9	880.7	.2414
106	331.9	1215.1	880.2	.2435
107	332.6	1215.3	879.7	.2456
108	333.3	1215.6	879.2	.2477
109	334	1215.8	878.7	.2499
110	334.6	1216	878.3	.2521
111	335.3	1216.2	877.8	.2543
112	336	1216.4	877.3	.2564
113	336.7	1216.6	876.8	.2586
114	337.4	1216.8	876.3	.2607
115	338	1217	875.9	.2628
116	338.6	1217.2	875.5	.2649
117	339.3	1217.4	875	.2652
118	339.9	1217.6	874.5	.2674
119	340.5	1217.8	874.1	.2696
120	341.1	1217.9	873.7	.2738
121	341.8	1218.1	873.2	.2759
122	342.4	1218.3	872.8	.2780
123	343	1218.5	872.3	.2801
124	343.6	1218.7	871.9	.2822
125	344.2	1218.9	871.5	.2845
126	344.8	1219.1	871.1	.2867
127	345.4	1219.3	870.7	.2889
128	346	1219.4	870.2	.2911
129	346.6	1219.6	869.8	.2933
130	347.2	1219.8	869.4	.2955
131	347.8	1220	869	.2977
132	348.3	1220.2	868.6	.2999
133	348.9	1220.4	868.2	.3020
134	349.5	1220.5	867.8	.3040
135	350.1	1220.7	867.4	.3060
136	350.6	1220.9	867	.3080
137	351.2	1221	866.6	.3101
138	351.8	1221.2	866.2	.3121
139	352.4	1221.4	865.8	.3142
140	352.9	1221.5	865.4	.3162

PROPERTIES OF SATURATED STEAM (*continued*).

Absolute pressure per sq. in.	Temperat're in degrees.	Heat units from zero, per lb.	Latent heat. in degrees:	Density or weight of one cubic ft.
Lbs.	Fähr.	Fähr.	Lbs.
141	353.5	1221.7	865	.3184
142	354	1221.9	864.6	.3206
143	354.5	1222	864.2	.3228
144	355	1222.2	863.9	.3250
145	355.6	1222.4	863.5	.3273
146	356.1	1222.5	863.1	.3294
147	356.7	1222.7	862.7	.3315
148	357.2	1222.9	862.3	.3356
149	357.8	1223	861.9	.3357
150	358.3	1223.2	861.5	.3377
155	361	1224	859.7	.3484
160	363.4	1224.8	857.9	.3590
165	366	1225.5	856.2	.3695
170	368.2	1226.2	854.5	.3798
175	370.8	1226.9	852.9	.3809
180	372.9	1227.7	851.3	.4009
185	375.3	1228.3	849.6	.4117
190	377.5	1229	848	.4222
195	379.7	1229.7	846.5	.4327
200	381.1	1230.3	845	.4431

Table giving the mean effective pressure in a steam cylinder, when the absolute pressure at cut-off and the point of cut-off are known. If, for example, the absolute pressure (gauge plus 15) at cut-off is 160 pounds, and the point of cut-off is at 1 stroke, the M. E. P. may be found by tracing the horizontal distance from 160 in the first column to the column headed 6, which gives 69.60 pounds.

Absolute Pressure	NUMBER OF TIMES THE STEAM IS EXPANDED.																	
	4	5	6	7	8	9	10	11	12	13	14	15	16	17	18	19	20	21
50	93.85	98.70	93.90	91.00	19.20	17.75	16.50	15.40	14.50	13.70	12.95	12.35	11.75	11.10	10.80	10.35	10.00	9.650
55	82.83	88.10	83.10	80.20	21.12	19.53	18.15	16.94	15.95	15.07	14.24	13.58	12.92	12.31	11.88	11.38	11.00	10.61
60	85.82	91.32	87.84	84.80	23.04	21.30	19.60	18.48	17.40	16.44	15.64	14.82	14.10	13.52	12.96	12.42	12.00	11.58
65	88.80	94.54	91.48	88.40	24.96	23.07	21.45	20.02	18.86	17.81	16.83	16.06	15.27	14.43	14.04	13.46	13.00	12.54
70	91.79	97.74	94.80	91.70	26.88	24.84	23.10	21.56	20.30	19.18	18.13	17.29	16.45	15.64	15.13	14.49	14.00	13.51
75	94.77	100.88	98.00	94.90	28.80	26.62	24.75	23.10	21.75	20.55	19.43	18.52	17.62	16.85	16.20	15.52	15.00	14.47
80	97.74	104.00	101.20	98.10	30.72	28.40	26.70	24.64	23.20	21.93	20.72	19.76	18.80	17.76	17.28	16.56	16.00	15.44
85	100.74	107.20	104.40	101.30	32.64	30.17	28.05	26.18	24.65	23.39	22.31	20.89	19.87	18.87	18.36	17.59	17.00	16.40
90	103.73	110.40	107.60	104.50	34.56	31.95	29.70	27.73	26.10	24.68	23.31	22.33	21.15	19.98	19.44	18.63	18.00	17.37
95	106.71	113.60	110.80	107.70	36.48	33.72	31.35	29.26	27.55	26.03	24.60	23.46	22.32	21.09	20.52	19.68	19.00	18.33
100	109.70	116.80	114.00	110.90	38.40	35.50	33.01	30.80	29.00	27.40	26.00	24.70	23.50	22.20	21.60	20.70	20.00	19.30
105	112.68	120.00	117.20	114.10	40.32	37.37	34.85	32.54	30.60	28.77	27.19	25.83	24.67	23.31	22.68	21.73	21.00	20.26
110	115.65	123.10	120.80	117.70	42.24	39.05	36.30	33.88	31.90	30.14	28.49	27.17	25.85	24.43	23.76	22.77	22.00	21.23
115	118.65	126.20	124.00	120.80	44.16	40.83	37.95	35.42	33.35	31.51	29.78	28.40	27.03	25.53	24.84	23.90	23.00	22.19
120	121.62	129.30	127.20	123.90	46.08	42.60	39.60	36.96	34.80	32.88	31.08	29.64	28.20	26.64	25.92	24.94	24.00	23.16
125	124.62	132.40	130.40	127.00	48.00	44.37	41.95	39.50	36.25	34.25	32.37	30.87	29.37	27.75	27.00	25.87	25.00	24.12
130	127.61	135.50	133.60	130.10	49.92	46.15	43.50	40.80	37.40	35.40	33.67	32.11	30.55	28.86	28.08	26.91	26.00	25.05
135	130.59	138.60	136.80	133.20	51.84	47.92	45.15	42.20	38.50	36.50	34.86	33.34	31.78	29.97	29.16	27.94	27.00	26.05
140	133.58	141.70	139.90	136.20	53.76	49.70	46.80	43.80	40.00	38.00	36.36	34.88	33.30	31.48	30.64	29.38	28.00	27.05
145	136.56	144.80	143.10	139.30	55.68	51.47	47.85	44.80	41.00	39.00	37.35	35.81	34.07	32.10	31.23	30.01	29.00	27.98
150	139.55	147.90	146.30	142.40	57.60	53.25	49.50	46.20	42.50	40.50	38.85	37.05	35.25	33.30	32.40	31.05	30.00	28.95
155	142.52	151.00	149.50	145.50	59.52	55.02	51.00	47.40	44.00	42.00	40.34	38.52	36.64	34.71	33.78	32.08	31.00	29.91
160	145.52	154.10	152.70	148.60	61.44	56.80	52.80	49.00	45.40	43.40	41.73	39.80	37.80	35.83	34.88	33.12	32.00	30.88
165	148.50	157.20	155.90	151.70	63.36	58.57	54.45	50.50	46.80	44.80	43.11	41.15	39.15	37.15	35.18	34.15	33.00	31.84
170	151.50	160.30	159.10	154.80	65.28	60.35	56.10	52.00	48.20	46.20	44.53	42.55	40.55	38.55	37.52	35.45	34.00	32.81
175	154.50	163.40	162.30	157.90	67.20	62.13	57.75	53.50	49.60	47.60	45.86	43.88	41.88	39.86	38.86	36.72	35.00	33.77
180	157.50	166.50	165.50	161.00	69.12	63.90	59.40	55.10	51.20	49.20	47.41	45.40	43.40	41.38	39.38	37.26	36.00	34.74
185	160.50	169.60	168.70	164.10	71.04	65.67	61.05	56.98	53.00	51.00	49.19	47.15	45.15	43.12	41.07	38.96	37.00	35.70
190	163.50	172.70	171.90	167.20	72.96	67.45	62.70	58.52	54.50	52.50	50.67	48.63	46.63	44.58	42.52	40.44	38.50	36.67
195	166.50	175.80	175.10	170.30	74.88	69.22	64.35	60.06	56.00	54.00	52.15	50.10	48.10	46.05	44.00	41.92	40.00	37.63

Table for Calculating the Compression Pressure and Temperature of a Gas Engine.

A	B	C	D	E	F	G
3.	.4771213	50.	4.407	4.264	146.89	142.13
3.05	.48429.8	48.78	4.506	4.358	147.74	142.88
3.1	.4913617	47.62	4.606	4.452	148.58	143.62
3.15	.4983106	46.51	4.707	4.547	149.42	144.36
3.2	.50515	45.45	4.808	4.643	150.25	145.10
3.25	.5118834	44.44	4.910	4.739	151.00	145.82
3.3	.5185139	43.48	5.011	4.835	151.87	146.53
3.35	.5250448	42.55	5.115	4.932	152.67	147.23
3.4	.5314789	41.66	5.217	5.030	153.47	147.93
3.45	.5378191	40.82	5.322	5.128	154.25	148.63
3.5	.544068	40.	5.426	5.226	155.03	149.32
3.55	.5502284	39.22	5.531	5.325	155.80	150.
3.6	.5563025	38.46	5.637	5.424	156.57	150.66
3.65	.5622929	37.74	5.742	5.524	157.32	151.33
3.7	.5682017	37.04	5.848	5.624	158.08	151.99
3.75	.5740313	36.36	5.956	5.724	158.82	152.65
3.8	.5797836	35.71	6.064	5.825	159.56	153.30
3.85	.5854607	35.09	6.171	5.927	160.29	153.94
3.9	.5910646	34.48	6.280	6.029	161.02	154.57
3.95	.5965971	33.9	6.389	6.131	161.73	155.21
4.	.60206	33.33	6.498	6.233	162.45	155.83
4.1	.6127839	32.26	6.718	6.440	163.86	157.07
4.2	.6232493	31.25	6.940	6.648	165.25	158.28
4.3	.6334685	30.31	7.164	6.858	166.62	159.48
4.4	.6434527	29.41	7.390	7.069	167.96	160.66
4.5	.6532125	28.57	7.618	7.282	169.29	161.82
4.6	.6627578	27.77	7.847	7.496	170.59	162.96
4.7	.6720979	27.03	8.078	7.712	171.88	164.09
4.8	.6812412	26.32	8.311	7.929	173.15	165.20
4.9	.6901961	25.64	8.546	8.148	174.41	166.29
5.	.69897	25.	8.783	8.368	175.64	167.37
5.1	.7075702	24.39	9.020	8.590	176.87	168.43
5.2	.7160033	23.81	9.260	8.813	178.07	169.48
5.3	.7242759	23.25	9.501	9.037	179.26	170.52
5.4	.7323938	22.73	9.744	9.263	180.44	171.54
5.5	.7403627	22.22	9.988	9.490	181.60	172.55
5.6	.748188	21.74	10.234	9.719	182.75	173.55
5.8	.763428	20.83	10.73	10.180	185.01	175.50
6.	.7781513	20.	11.233	10.646	187.22	177.42

Column A gives the compression ratio of the cylinder; column B the logarithm of the compression ratio; column C the per cent. of clearance corresponding to any given compression ratio.

Column D gives the figures for the compression pressure corresponding to a theoretical one-pound initial pressure. The figures in this column, corresponding to any given compression ratio, if multiplied by the initial pressure in that cylinder (14.7 minus resistant strength of inlet valve spring), will give the proper compression pressure corresponding to the initial pressure for that cylinder.

Similarly, column E gives the compression pressure corresponding to a theoretical one-pound initial pressure for a scavenging cylinder, whose proper compression pressure may be found by multiplying by the initial pressure.

Columns F and G give the compression temperature for a plain and a scavenging cylinder, respectively, corresponding to a theoretical 100-degree absolute initial temperature. The proper compression temperature for a cylinder of given per cent. clearance and compression ratio may be found by multiplying the figures in either of these columns by $\frac{1}{100}$ of the ascertained absolute compression temperature in the plain or the scavenging cylinder in question. Table from *Power*.

INDEX.

- Ackerman stud steering axle, 36-41.
Air feed pumps, 221-231.
Alarms, low water, 158-159.
Ampere, the, 542.
Ampere-second, 542.
Angle iron underframes, 68.
Angles of steering, 46, 47, 52, 53.
Atkinson's gas engine, 367, 375.
"Auto" carburetter, 419-421.
Automobile, the word, 1.
Automatic valves, 224-227.
Axles, steering, Ackerman's stud, 36-41.
 Daimler, 40.
 Duryea, 38.
 Haynes-Apperson, 39.
 Loomis, 44.
 Panhard, 48.
 Riker, 42.
- Baffle plates, 171.
Bailey pneumatic tire, 115.
Balance gears, 24-34 (see differential gears).
Ball bearings, 597, 598.
 limitations of, 599-600.
Band brakes, operation of, 591.
B. & P. pneumatic tire, 117.
Bearings, rotative, balls and rollers, 597, 598-599.
 conditions of using, 599-601.
 overcoming friction by, 597-599.
 superiority to plain bearings, 597.
 theory of, 597-598.
 uses of, 597.
Bell transmission, Daimler, 452-454, 476, 482, 483, 485.
Benz motor, 9.
 carriage, 438, 491.
 ignition circuit, 438, 440-443.
 muffler, 374.
Blow off cock of steam boilers, 154.
Roller, steam, baffle plate, 171.
 De Dion, 181, 194-195.
 feed injector, 212-213, 214, 215.
 feed pumps, 214-217, 221-224, 227-231.
 flues, 166-167, 168-171, 172, 173-175.
 "Lifu" water tube, 196-198.
 attachments of, 155-166.
 blow off cock of, 154.
 blowing off, 607-608.
 circulation in water tube, 177, 179, 180, 182, 184, 186, 188, 189, 197, 198.
 computing capacity of, 150.
 excessive pressure in, 161-163.
 feeders for, 212-231.
 filling of, 607.
 "flash boiler," 200-211.
 generation of steam in, 151, 152.
 heating surface of, 166-168.
 incrustation in, 607.
 power capacity of, 148-149.
 riveting plates of, 153.
 sectional construction in, 178-182.
 securing flues of, 153.
 steel or copper flue, 168-171.
 theory and construction of, 147-154.
 varieties of, 154.
 water level in, 607.
 water tube, 176-199.
 water tube, advantages of, 176-183.
Boyle's Law of Gases, 262, 345-350.
- Brakes for road wheels, 590-596.
 care of, 596.
 constricting band, 592, 593, 596.
 constricting effort in, 590.
 diameter of drum of, 591.
 drum and band, 590.
 expanding band, 596, 596.
 formula for acting distance, 594.
 formula for required pull, 595.
 formula for resistance to, 592-593.
 principle of torque in, 591.
 requirements in, 590.
 shoe, 590.
 varieties of, 596.
- Burner, coil vaporizer for, 252-254.
 for volatile fuels, 233-249.
 fuel regulators for, 238, 239, 240, 241-244.
 gasoline, 240-249.
 kerosene, 233-240.
 "torch" lighter, 249-252.
 troubles with, 612.
 vaporized fuel, 247, 248, 234, 235, 236, 249-256.
- Burning-back, cause and effect of, 246, 612.
- Calorific value of volatile fuels, 392-395.
Carburetters, 332, 337, 338, 406-423.
 "Auto," 419-421.
 Daimler, 407-409, 411, 413-414, 415, 421.
 Daimler-Maybach, 410, 413-414.
 De Dion, 333, 415, 416, 423.
 Duryea, 414-416.
 Huzelstein, 417-419.
 James, 418, 419.
 Longuemare, 410-411.
 Maybach, 408-410, 415.
 Peugeot, 412.
 troubles with, 421-422.
 types of, 338, 339, 406-407.
- C. E. M. F., 543, 561, 567.
Charron carriage, 330, 490.
Church's steam carriage, 16-18.
Circulation in water tube steam boilers, 177, 179, 180, 182, 184, 186, 188, 189, 197, 198.
Coil vaporizers, 252-254.
Combination gasoline and electric vehicles, 537, 564-565.
Compensating gears, 24-34 (see differential gears).
Controller, electric circuit, 575-576.
 varieties of, 575-576.
Coulomb, The, 542.
Counter electromotive force, 543.
Creeping of pneumatic tires, 127-129.
Crossley's gas engine, 357, 358, 381-382, 384.
Cugnot's automobile, 7-8, 21.
Cut off, steam engine, 269, 270, 283, 2 4-285.
 varying point of, 285, 297, 309, 310, 311, 317, 611.
- Cycle of gas engines, 333, 334-335, 335-337, 372, 378-380.
 of steam engines, 268, 269, 270, 271, 272, 275.
- Daimler, Gottlieb, viii, 8, 407.

- Daimler, axle, steering, 40.
 belt transmission, 452-454, 476, 482, 483, 485.
 carburetter, 407-408, 410, 413-414, 415, 421.
 carriages, 408, 413, 452, 453, 454, 478-459, 475-492, 482-485, 486, 488, 490, 491, 492.
 differential gear, 34.
 gasoline engine, 339, 342, 346, 348, 363, 475, 476, 477, 478, 481, 489, 493.
 gear, transmission, 456, 458-459, 492.
 governor, 342, 475-477, 479, 480.
 hot tube ignition, 339.
 piston air valve, 477, 478-480.
 reversing gear, 458, 459, 468.
 speed-changing, 452-454, 458-459, 492.
 V-shaped engine, 477, 478, 479, 481, 489.
- Daimler-Maybach carburetter, 410, 413-414.
 Daniell cell, 543.
 Darracq carriage, 454.
 reversing gear, 454-455.
 "Dayton" electric ignition, 431, 446, 447, 448, 449, 460.
- De Dion-Bouton, 9.
 boiler, 181, 194-195.
 carburetter, 338, 415, 416, 423.
 carriage, 67, 89, 90, 91, 133, 337, 416, 436, 440, 471-473, 491, 493-501.
 gasoline motor, 337, 352, 433, 493, 494, 496, 496, 500, 501, 503.
 jointed axle, 90.
 jump-spark circuit, 433, 435, 436-440.
 operating system, 495-501.
 reversing gear, 473.
 speed-changing device, 471-473.
 steering gear, 50, 89.
 underframe, 67.
- Didier speed-changing device, 461-463.
 Diesel gas engine, 339, 375, 424-425, 427.
 ignition method, 424, 427.
- Differential gears, 24-34.
 bevel, 27, 28.
 Brown-Lipe, 29, 30.
 Daimler, 34.
 for tricycles, 25.
 Riker's hub, 32.
 spur, 28-31.
 Thornycroft's, 33.
 universal joint, 31.
- Drum brake, diameter of, 591.
 Dunlop pneumatic tire, 120, 128, 141.
 Duryea, Charles E., 73, 79, 98, 99, 360, 363.
 axle, steering, 38.
 brake, expanding band, 596.
 carburetter, 414-416.
 carriage, 2, 38, 70-72, 74, 434, 466-471, 503-510.
 chain, self-oiling driving, 509.
 gasoline carriages, 2, 50, 53, 71, 360, 506-510.
 gasoline engines, 360, 387, 503-506.
 governor, 504-506.
 pneumatic tire experiments, 135-139.
 reversing gear, 470-471.
 self-oiling drive chain, 509.
 single lever control, 507-510.
 speed-changing device, 466-471.
 steering pivots, 38, 76.
 three-wheeler, 70, 73, 74, 75-76.
- Dyke carriage, 437, 530-536.
- Dynamo-electrical generator, 431, 446, 447, 448, 449, 460, 538, 546-566, 564, 565.
 armature of, 549, 550, 552-553, 555, 556, 567.
 armature core, 552.
 armature, polarisation of, 555-557.
 brushes of, 549, 550, 555.
 commutator of, 550, 553-554.
 field magnets of, 550.
 operation of, 549-550, 555-558.
 pole pieces of, 550.
 varieties of, 551.
- Driving axle, Thornycroft, 33.
- Electrical activity, 538, 545.
 back pressure, 543.
 circuit, Ohm's law of, 544-545.
 condenser, 538.
 current, 538, 549.
 dynamos and motors, 548.
 ignition, 339-340, 429, 436, 431-456.
 induction, 546-547.
 motor, advantages of, 565.
 and dynamo comparison of, 558-559.
 armature of, 559, 561.
 attachments of, 562, 564.
 speed and torque of, 562-563.
 varying speed of, 566-576.
 potential, 538.
 pressure, 542-543.
 quantity, 542.
 resistance, 542.
 storage battery, 564, 565.
 transmission, 538.
 units, 539-540.
- Electricity, as a force, 538.
 compared to heat, 538, 539.
- Electric motor, field magnets of, 561.
 Lundell, 559, 560.
 operative principle of, 557-558.
- Electric vehicles, 537, 539, 544, 554, 560, 565, 567, 575, 579.
 circuit changing in, 567-574.
 controller, 575-576.
- Electromobile, 2.
- Electromotive force (E. M. F.), 538, 543, 544, 552, 555, 558.
- Engine, steam, preparing to start, 603-610.
- Expansion of steam, 262-265, 268, 270, 271, 272, 283-285, 286.
- Feeders for steam boilers, 212-231.
- Feed regulators for volatile fuels, 238, 239, 240, 241-244, 252, 253.
- Field tube boilers, 183-184.
- Fire engines, self-propelled, 326-329.
- Flash "boilers," 9, 200-211.
 Haythorn joints for, 209, 211.
 operation of, 200, 203, 204-206, 207, 208-209, 210-211.
 Rowe tubes for, 209, 211.
 Serpollets, 200-203, 209, 332.
 varieties of, 204-211.
- Flues, boiler, 166-171.
 copper, superiority of, 168-171.
 heating surface increased by, 166-167.
 number of, 167, 172, 173-175.
- Fore-carriages, 21, 58, 59.
- Fuel feed pump, 221-224.
- regulators, 238, 239, 240, 241-244.
- Fuels, hydrocarbon, liquid or volatile, 7, 232-235, 239, 240, 332, 334, 335.

INDEX.

Fuels, hydrocarbon, etc. (continued).

burners for, 232-249.
 calorific value of, 392-396.
 feed regulators, 238, 239, 240, 241-244,
 252, 263.
 for gas engines, 232-233, 239, 332,
 334, 335, 338, 340, 344-349, 354-355,
 358, 359-360, 370-373, 392-395, 406-423,
 424-450.
 vaporizing and burning of, 234, 235,
 236-237, 239-240, 246, 247-249.

G. & J. pneumatic tire, 119, 139-140.

Gas engine, advantages of, 331-332.
 Atkinson, 357, 375, 378-379, 380, 381,
 384.

"Buffalo," 390.

conditions of operation, 343-345.

cooling cylinders of, 356-369.

Crossley, 357, 358, 381, 382, 384.

cycle of, 333, 334, 335-336, 372, 378-380.

cycle of, Otto, 333, 334-335, 372, 380.

Daimler, 339, 343, 368.

De Dion, 337, 433, 508.

Diesel, 339, 375, 424-425, 427.

Duryea, 337, 503-506.

efficiency of, 385-396.

estimating horse-power of, 396-405.

fuel mixtures, 370-373.

governors for, 341-342, 475-477, 479,
 480, 481, 504-506, 511, 514-516, 522,
 524.

Haynes-Apperson, 510-511.

Hornsby-Akroyd, 339, 357, 362, 371,
 425-427.

heat and power losses in, 373-384.

Ignition of charge in, 339, 370-384,
 424-450.

Kalnz, 367.

Knox, 366, 367.

method of starting, 334.

operative cycle of, 333, 334-335, 336-
 337, 372, 378-380.

operative principles, 331-405.

Otto, 339, 427.

parts of, 337-343, 346.

piston, 333, 336, 340, 341, 342-343.

Simms, 368.

theory of, 332-334.

St. Louis, 519, 520.

volatile fuels for, 232-233, 239, 332,
 334, 335, 338, 340, 344-349, 354-355,
 358, 359-360, 370-373, 392-395, 406-423,
 424-450.

Winton, 513.

Gases, Boyle's law of, 262, 345-350.

(Gay Lussac's law of, 265.

Joule's law of, 268.

pressure and volume of, 262, 345-
 350.

temperature and volume of, 265,
 266-267, 346, 352-354.

Gasoline burners, 240-249.

Gasoline carriage, Benz, 438, 491.

breakage and wear in, 619.

Charron, 330, 490.

Daimler, 408, 413, 452, 453, 454, 455-
 459, 474-492, 482-485, 486, 488, 490,
 491, 492.

Darracq, 454.

De Dion, 67, 89, 90, 91, 133, 337, 416,
 436, 440, 471-473, 491, 493-501.

directions for starting, 616.

Duryea, 2, 38, 50, 53, 70-72, 74, 360,
 434, 466-471, 503-510.

Dyke, 437, 530-536.

Gasoline carriage (continued).

Haynes-Apperson, 39, 99, 434, 464-466,
 510-513.

Hertel, 36.

Knox, 73, 75.

lubrication of, 613-614.

Mors, 83, 491.

Packard, 522-525.

Panhard, 35, 48, 87, 455, 456-458, 474,
 484, 486-492.

Peerless, 114, 525-530.

Peugeot, 481, 487, 491.

Pretot, 58.

St. Louis, 518-521.

Winton, 61, 462, 463, 513-518.

Gasoline engine, Daimler, 339, 342, 346,
 348, 475, 476, 477, 478, 481, 489, 493.

Duryea, 360, 387, 503-506.

De Dion, 337, 352, 493, 494, 495, 496,
 500, 501.

failure to operate, 614-615.

imperfect combustion, 619-620.

starting, 614.

Gasoline feeding pump, 256-258.

quality of, used, 608.

tank, filling of, 608.

Gauge glass, check valve for, 157.

indications of, 155.

troubles with, 156-158.

Gauge, steam, 159-161.

Duplex steam and air, 162.

varieties of, 159-160.

Gay Lussac's Law of Gases, 265.

Gear, balance (see differential gears),
 24-34.

compensating (see differential
 gears), 24-34.

transmission, Daimler, 456, 458-459,
 492.

Generation of steam, 260.

Generator, "American" magneto, 443.

dynamo-electrical, 431, 446, 447, 448,
 449, 450.

Holtzer-Cabot magneto, 440, 442,
 511.

Simms-Bosch magneto, 444, 446-450.

Goodyear pneumatic tire, 122, 141-142.

Governor, Daimler, 342, 475-477, 479, 480.

for gas engines, 341-342, 475-477, 479,
 480, 481, 504-506, 511, 514-516, 522,
 524.

Haynes-Apperson, 511.

Packard, 522, 524.

Peugeot, 481.

Winton pneumatic, 514-516.

Graphite, 610.

as a lubricant, 605.

Grappler pneumatic tire, 121.

Gurney's steam carriage, 10-13.

Hancock's steam carriage, 13-16.

Haynes-Apperson axle, 39.

carriage, 39, 99, 434, 464-466, 510-513.

gasoline engine, 510-511.

governor, 511.

reversing gear, 464, 466.

speed-changing device, 464-466.

Haythorn joints for flash "boilers," 209,
 211.

Heating surface of steam boilers, 166-
 168.

Hornsby-Akroyd gas engine, 339, 357, 362,
 371, 425-427.

method of ignition, 425.

Horse-power, in steam engines, 272-275.

Hertel carriage, 36.

SELF-PROPELLED VEHICLES.

- Hot tube ignition, Daimler, 336.
Hurtu electric carriage, 56.
Iluzelstein carburetter, 411-419.
Hydrocarbon, fuels, 232-233, 239, 332, 334, 335.
- Ignition, 339-340.
Benz circuit, 438, 440-443.
circuit, troubles with, 615-616, 618-619.
Dayton electric, 431, 446, 447, 448, 449, 450.
De Dion, 433, 435, 436-440.
Diesel method, 424, 427.
electrical, 339-340, 429, 430, 431-450.
Hornsby-Akroyd method, 425.
hot head, 339, 425-427.
hot tube, 339, 426, 427, 428-431.
Otto method, 427, 428.
results of, 370-384.
- Indicator, steam engine, 264, 265.
Injector, boiler feeding, 212-213, 214, 215.
- James carburetter, 418, 419.
steam carriage, 17.
- Jointed axle, De Dion, 90.
Joule's Law of Gases, 268.
Jump-spark circuit, De Dion, 433, 435, 436-440.
- Kalnz gas engine, 367.
Kerosene burners, 233-240.
Lifu, 236.
Longuemare, 233-235.
- Knox carriage, 73, 75.
gasoline engine, 366, 367.
- Lap and lead, of steam valves, 277-279, 281, 282, 283, 285.
Leclanche cell, 543.
Leverage, balance of, 37.
Lifu compound steam engine, 323-325.
kerosene burner, 236.
water tube boiler, 196-198.
wheel for truck, 110.
- Link motion, Stephenson, 279-283, 285, 290, 293, 295, 299, 317, 323.
- Locomobile, the word, 1.
Locomobile steam carriage, 64, 157, 166-168, 174, 287, 288, 289-292.
- Locomotives, construction of wheels, 44-45.
varieties of, 6, 20.
Longuemare carburetter, 410-411.
kerosene burner, 233-235.
Loomis steering axle, 44.
Low water alarms, 158-159.
Lubricants, 603-606.
feed cups for, 604.
for gas engine cylinders, 603-604.
graphite, its use as, 605.
qualities essential in, 606.
superiority of mineral, 604.
tests and qualities of, 605-606
- Lussac's Law of Gases, 265.
- McKay steam carriage, 66, 212, 316-320.
underframe, 66.
- Magnet, 538.
production of, 547.
properties of, 547-548.
- Magneto-electrical generators, 431, 441, 443-450, 503.
"American," 443.
Holtzer-Cabot, 440, 442, 511.
Slunns-Bosch, 444, 446-450.
- Magnetic field, 555.
distortion of, 556-557.
induction, 543, 555.
- Magnetism, residual, 552, 555.
Michelin pneumatic tire, 118, 139, 140.
Miner's inch, 542.
Montauban-Marchandier, speed-changing device, 459, 460-461.
Mors' carriage, 83, 491.
Motor wheels, 23.
Muffler, Benz, 374.
Multiple circuit, 543, 556.
Munger pneumatic tire, 123, 142.
- Ohm's law, 544-545.
Oil feed cups, 604.
Oils, organic, useless for automobiles, 604.
Operating carriages, De Dion system, 495-501.
- Otto, Dr. N. A., his gas engine cycle, 333, 334-335, 372, 380.
gas engine, 339, 427.
method of ignition, 427, 428.
- Packard carriage, 523-525.
governor, 522, 524.
- Panhard-Levassor, 9.
axle, steering, 48.
carriage, 35, 48, 87, 413, 455, 456, 458, 474, 494, 498-492.
change-speed gear, 455, 456-458.
engines, 489.
light car, 35.
reversing gear, 455, 457.
steering connections, 48.
- Parallel circuit, 543, 566.
Peerless carriage, 114, 525-530.
- Peugeot, 9, 487, 491.
carburetter, 412.
carriages, 412, 481, 487, 491.
governor, 481.
- Piston air valve, 477, 478-480.
gas engine, 333, 336, 340, 341, 342-343.
steam engine, 263, 267, 269, 275, 276-277, 279, 284, 293, 302, 303, 305, 307, 313.
- Pneumatic tires, effects of, 84-86.
experiments, Duryea, 135-139.
Tillinghast, 124, 126.
- Poppet valves for gas engines, 333, 339, 340.
- Pressure, of steam, 262-265, 266-268, 270, 271, 272, 275, 286.
- Pretot carriage, 58.
Pump air feed, 227-231.
for gasoline fuel, 256-258.
fuel feed, 221-224.
- Pumps, boiler feed, 214-217, 221-224, 227-231.
Punctured pneumatic tires, 122-124.
- Radius rods, 82, 83, 87.
- Reading steam carriage, 65, 146, 174, 304, 305-309.
underframe, 65.
- Regulators, fuel feed, 236, 238, 239, 240, 241-244, 246, 247, 250, 252, 253.
Thermostat, 206, 207, 218.
water level, for boilers, 217-221.
- Resiliency of pneumatic tires, 134-139.
- Reversing gear, Daimler, 458-459.
Darracq, 454-455.
De Dion-Bouton, 473.
Duryea, 467, 468, 470-471.

INDEX.

Reversing gear (continued).

- Haynes-Apperson, 464, 466.
- Montauban-Marchandier, 459, 460-461.
- Panhard-Levassor, 455, 457.
- Winton, 462, 463.
- Riker axle, steering, 42.
- carriage, 32, 42, 69.
- differential gear, 32.
- underframe, 69.
- Rods, distance or radius, 82, 83, 87.
- Roller bearings, 597, 598.
- conditions of using, 600-601.
- constructional points on, 601-602.
- Rowe tube for flash boilers, 269, 211.
- Safety valves, 161, 163-165.
- Scavenging cylinder, 374-377.
- stroke, 334.
- Self-propelled fire engines, 326-329.
- Separators, steam, 171-172.
- Series circuit, 543, 566.
- Serpollet, Leon, 9, 332.
- engine and carriage, 302-305.
- flash generator, 9, 200-203, 209, 332.
- water feed system, 321-224.
- Shunt dynamos, 561, 552.
- Side slipping, 616-618.
- Slide valve, steam engine, 276, 277-279, 280, 282, 283, 285, 287, 290, 295, 302, 303, 304, 305, 307, 308, 309, 311, 312, 313, 314, 320, 322, 324, 325.
- Speed-changing devices, 320, 323, 360, 451-473.
- belt and pulley, 452-455.
- clutch, 466-473.
- Dalmier, 452-454, 458-459, 492.
- De Dion-Bouton, 471-473.
- Didler, 461-463.
- Duryea, 466-471.
- Foullmarion, 453.
- Haynes-Apperson, 464-466.
- meshing gear, 460-466.
- Montauban-Marchandier, 459, 460-461.
- Panhard-Levassor, 455, 456-458.
- principles of, 451-452, 453, 454, 456, 460.
- shifting gear, 455-459.
- Winton, 462, 463.
- Simms gas engine, 368.
- Springs, 80-93.
- attachments for, 83-89.
- construction of, 89-91.
- dimensions of, 83-84, 86-87.
- formulae for, 91, 92.
- general theory of, 80-81.
- suspension of, 82-83.
- Stanley underframe, 64.
- Starting a gas engine, method of, 334.
- Steam and air gauge, 162.
- Steam boilers, advantages of water tube, 176-183.
- attachments of, 155-165.
- blow off cock, 154.
- circulation in water tube, 177, 179, 180, 182, 184, 186, 188, 189, 197, 198.
- computing capacity of, 150.
- excessive pressure in, 161-163.
- feeders for, 212-231.
- feed pump, 611-612.
- fire flue of, 166-175.
- "flash boiler," 200-211.
- heating surface of, 166-168.
- power capacity of, 148-149.

Steam boilers (continued).

- rapid generation of steam in, 151, 152.
- riveting plates of, 153.
- sectional construction in, 178, 182.
- securing flues of, 153.
- steel or copper flue, 168-171.
- theory and construction of, 147-154.
- Thornycroft, 190-193.
- water glass of, 609.
- water tube, 176-199.
- varieties of, 154, 181, 183-199.
- Steam carriage, 204-206, 224-227, 253.
- Church's, 16-18.
- Cotta, 56-58.
- Cugnot's, 718, 21.
- De Dion, 181, 194-195.
- Geneva, 185-187.
- Gurney's, 10-13.
- Hancock's, 13-16.
- James', 17.
- Lane, 175.
- "Locomotive," 64, 157, 166-168, 174, 237, 288, 289-292.
- McFay, 66, 173, 212, 316-320.
- Milwaukee, 174, 175.
- Reading, 65, 146, 174, 304, 305-309.
- Stearns, 78, 92, 311-316.
- Serpollet, 200-203, 221-224, 302-305.
- Sterling, 184-186.
- Toledo, 178, 187, 188, 292-294.
- Trevithick's, 9-10.
- Valee, 183.
- Victor, 166, 172-173, 175, 218-219, 227-229, 295-298.
- Steam cylinder, relief cocks of, 609.
- wearing out of valves, 610.
- Steam engine, compound, 611.
- cut off, 269, 270, 283, 284-285.
- varying point of, 285, 297, 309, 310, 311, 317.
- cycle of, 268-271.
- estimating horse-power, 272-275.
- indicator, 264, 265.
- reading of cards, 265, 268-271, 272.
- mean effective pressure, 276.
- operation of, 276-286.
- operative cycle of, 268, 269, 270, 271, 272, 275.
- piston, 263, 267, 269, 275, 276-277, 278, 284, 293, 302, 303, 305, 307, 313.
- slide valve, 276, 277-279, 280, 282, 283, 285, 287, 290, 292, 295, 302, 303, 304, 306, 307, 308, 309, 311, 312, 313, 314, 320, 322, 324, 325.
- theory of, 259-275.
- Steam compared to other gases, 259-260.
- expansion of, 262-265, 268, 270, 271, 272, 283-285, 286.
- forms of, 261-262.
- gauge, 159-161.
- generation of, 260.
- indicator cards, 263, 264, 265, 268-271.
- pressure of, 262-265, 266-268, 270, 271, 272, 275, 286.
- pressure and temperature of, 265-268, 271, 275.
- pressure and volume of, 262-265.
- separators, 171-172, 260.
- temperature of, 260, 261-262, 265-267, 271.
- valve, lap and lead of, 277-279, 281, 282, 283, 285.
- Stearns steam carriage, 78, 92, 311-316.
- Steering, angles of, 46, 47, 52, 53.

SELF-PROPELLED VEHICLES.

- Steering gear, Bolee, 53.
 Clarkson-Capel, 52.
 Cotta, 57.
 De Dion, 50, 89.
 Duryea three-wheeler, 33, 75-76.
 Gobron-Brillie, 51.
 Hurlu, 55.
 Knox, 75.
 Panhard, 48.
 rear wheel, 58.
 Thornycroft, 49.
- Stephenson link motion, 279-283, 285, 290,
 293, 296, 299, 317, 323.
- St. Louis carriage, 518-521.
 gasoline engine, 519, 520.
- Storage batteries, 537, 577-589.
 electrolyte, 584-587.
 "formation" of, 580-582.
 Gould, 581, 583, 586, 588.
 invention of, 578.
 period of charging, 587, 589.
 Plante, 580-582.
 principles of, 577-579.
 requirements in, 580.
 varieties of, 582.
- Stuffing box, leaky, 610.
- Temperature of steam, 260, 261-262, 265-
 267, 271.
- Thornycroft, John I., 104.
- Thornycroft compound engine, 319, 322.
 differential gear, 33.
 driving axle, 33.
 jointed countershaft, 93.
 road wagon and engine, 320-323.
 spring road wheels, 103, 104.
 steam boiler, 190-193.
 steering gear, 49.
 wagon underframe, 77.
- Three-wheeler, Duryea, 70, 73, 74, 75-76,
 521.
- Tillinghast, P. W., 124, 129.
- Tillinghast latest improved tire, 125.
 pneumatic tire, 124-126.
 single tube, 124-126.
- Tires, pneumatic, advantages of, 112-117.
 attachments for double tube, 139-
 140.
 Bailey, 115.
 B. & P., 117.
 care and repair of, 129-132.
 construction of, 119-122.
 creeping of, 127-129.
 Dunlop, 120, 128, 141.
 effects of, 84-86.
 G. & J., 119, 139-140.
 Goodyear, 122, 141-142.
 grappler, 121.
 Michelin, 118, 139, 140.
 Munger, 123, 142.
 on bicycles, 85, 86.
 opinions on, 113-114, 114-116, 120-121,
 124-125, 135-139.
 proportions of, 132-134.
 puncture, 122-124.
 resiliency of, 134-139.
 single tube, 124-127.
 Tillinghast, 124-126.
 use and effect of, 112-145.
- Tires, solid rubber, attaching, 107, 111.
- Tires (continued).
 comparison with pneumatics, 108,
 109.
 durability of, 109, 110.
 merits of, 106-108.
 opinions on, 105, 107, 108, 108-109,
 109-110.
 reducing vibration, 105.
 structure of, 110, 111.
 varieties of, 107, 108, 109.
- Torch, burner igniting, 242, 245, 247, 249-
 252.
- Trevithick's steam carriage, 9-10.
- Try-cocks, 155, 157.
- Underframes, 62-79.
 angle iron, 68.
 De Dion, 67.
 Duryea, 70.
 flexibility in, 64, 65, 66, 68, 69, 70,
 73, 78, 79.
 Knox, 72.
 McKay, 66.
 Reading, 65.
 Riker, 69.
 requirements in, 62.
 Stanley, 64.
 three-wheeled, 73-79.
 tubular, 63.
- Valve, automatic, 224-227.
 by-pass, 214-216, 217, 218.
 lap and lead of steam, 277-279, 281,
 282, 283, 285.
 poppet, for gas engines, 333, 379,
 340.
 "pop" safety, 163, 165.
 rule for pressure in safety, 164.
 safety, 161, 163-165.
- Vaporizers for fuel, 249-256.
- Victor steam carriage, 166, 172-173, 175,
 218-219, 227-239, 295-298.
- Volatile fuels, 7, 232-235, 239, 240.
 vaporizing and burning of, 234, 235,
 236-237, 239, 240, 246, 247-249.
- Volt, The, 542-543.
- Water jacket, non-freezing solutions
 for, 620.
- Watt, The, 545.
- Wheels, construction of, 94, 95.
 dimensions of, 95-96.
 dishing in, 95, 96.
 double interacting, 143-145.
 driving on all four, 54-61.
 driving on front, 55-57.
 for automobiles, 94-104.
 "Lifu" steam truck, 110.
 locomotive, construction of, 44-45.
 motor, 23.
 on using large, 101-104.
 requirements in, 94.
 steering on rear, 58, 59.
 Thornycroft spring, 103-104.
 tubular steel, 102.
- Winton carriage, 61, 462, 463, 513-518.
 gas engine, 512.
 speed-changing device, 462, 463.
 pneumatic governor, 514-516.
 reversing gear, 462, 463.

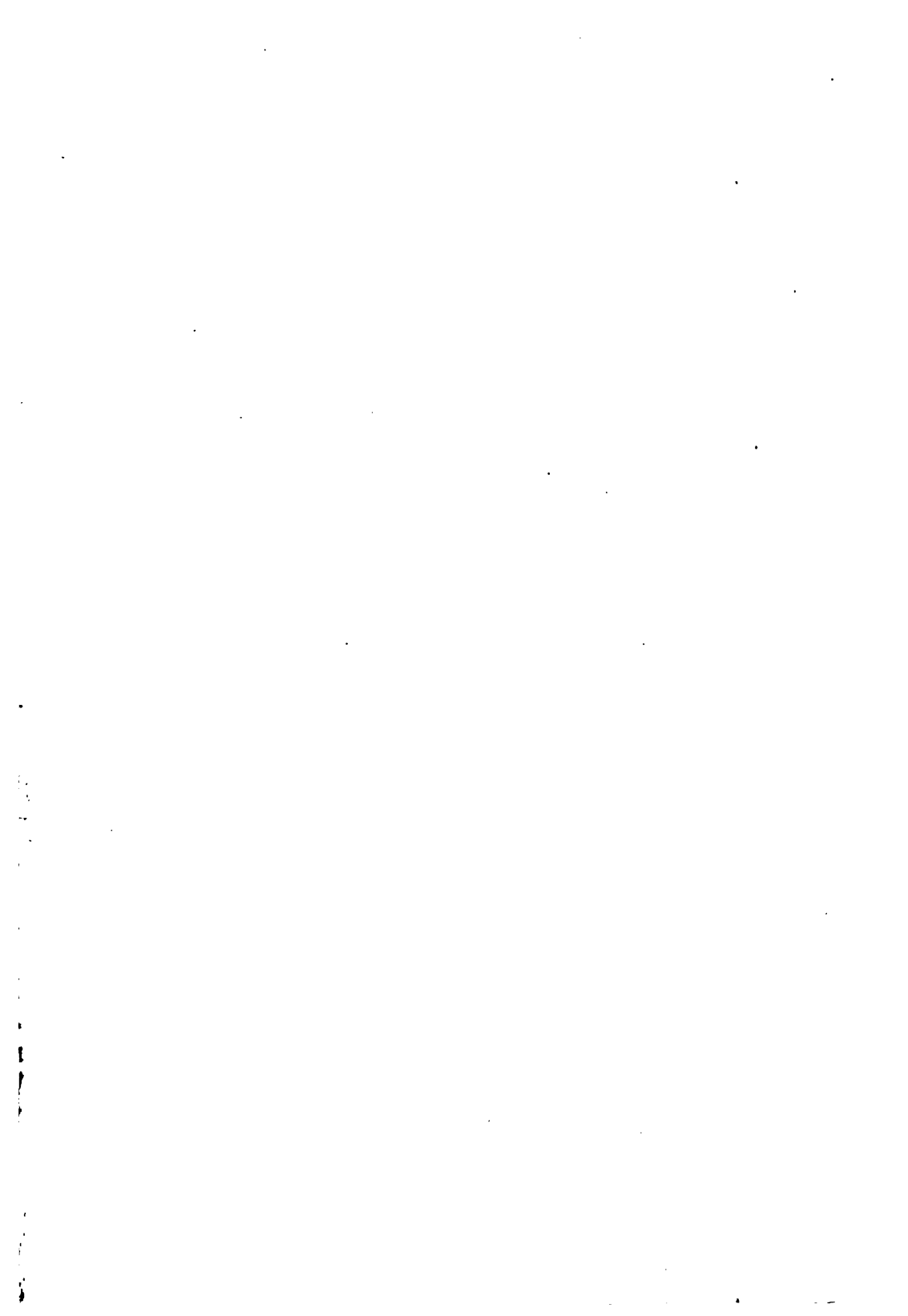

520 12104 1
40854

BLI



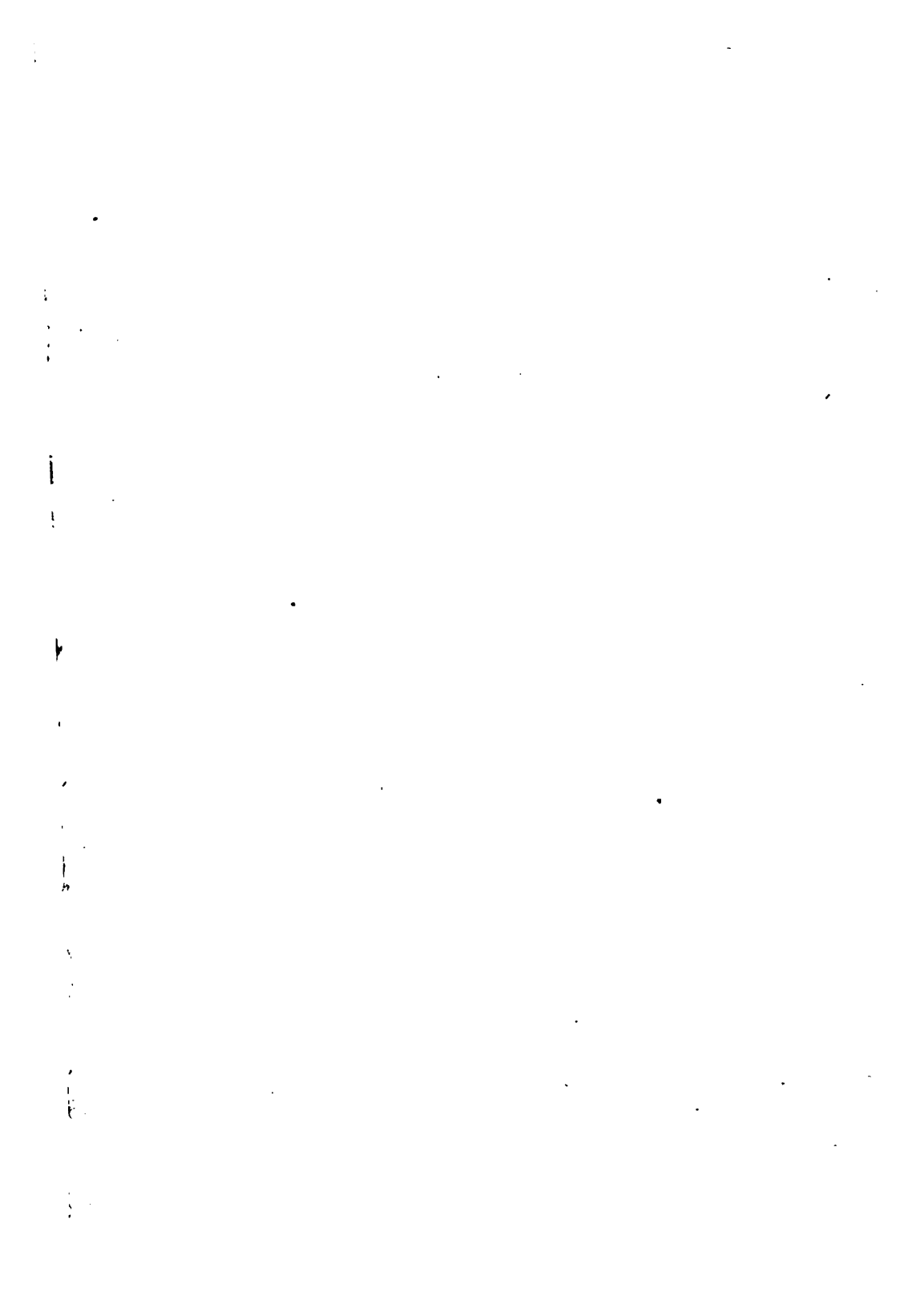

89090514506



B89090514506A

